

WALL MOUNTED SPLIT-TYPE AIR CONDITIONERS

SERVICE MANUAL

XIGMA

EXTRAFORCE series

Models

XG-EF21RHA

XG-EF27RHA

XG-EF35RHA

XG-EF50RHA

XG-EF70RHA

CONTENTS

Chapter 1 Product Specification	2
1.1 Photo of Product (For reference only)	2
<i>Indoor unit</i>	2
<i>Outdoor unit</i>	2
1.2 Outline Dimensions	3
<i>Indoor Unit</i>	3
<i>Outdoor unit</i>	3
Chapter 2 Refrigeration Diagrams	4
<i>Cooling Mode</i>	4
<i>Heating Mode</i>	5
Chapter 3 Wiring Diagram	6
<i>Indoor unit</i>	6
<i>Outdoor unit</i>	7
Chapter 4 Troubleshooting Guide.....	10
4.1 Error Code.....	10
4.2 Troubleshooting Guide.....	10
Chapter 5 Operation characteristic curve	17
Chapter 6 Brier description	22
6.1 Brier description of modes and functions.....	22

Chapter 1 Product Specification

1.1 Photo of Product (For reference only)

Indoor unit

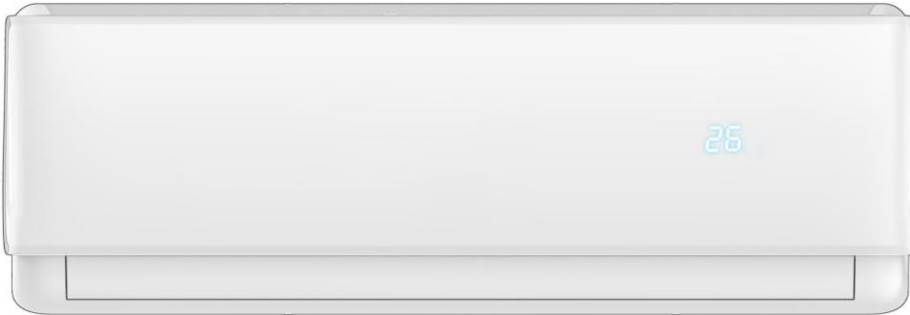

Outdoor unit



1.2 Outline Dimensions

Indoor Unit

MODE L	XG-EF21RHA	XG-EF27RHA	XG-EF35RHA	XG-EF50RHA	XG-EF70RHA
W(mm)	700	700	710	910	970
D(mm)	190	190	190	230	230
H(mm)	250	250	290	320	320

Outdoor unit

MODEL	XG-EF21RHA	XG-EF27RHA	XG-EF35RHA	XG-EF50RHA	XG-EF70RHA
W(mm)	680	680	680	790	790
D(mm)	250	250	250	290	290
H(mm)	420	420	420	530	530

Chapter 2 Refrigeration Diagrams

Cooling Mode

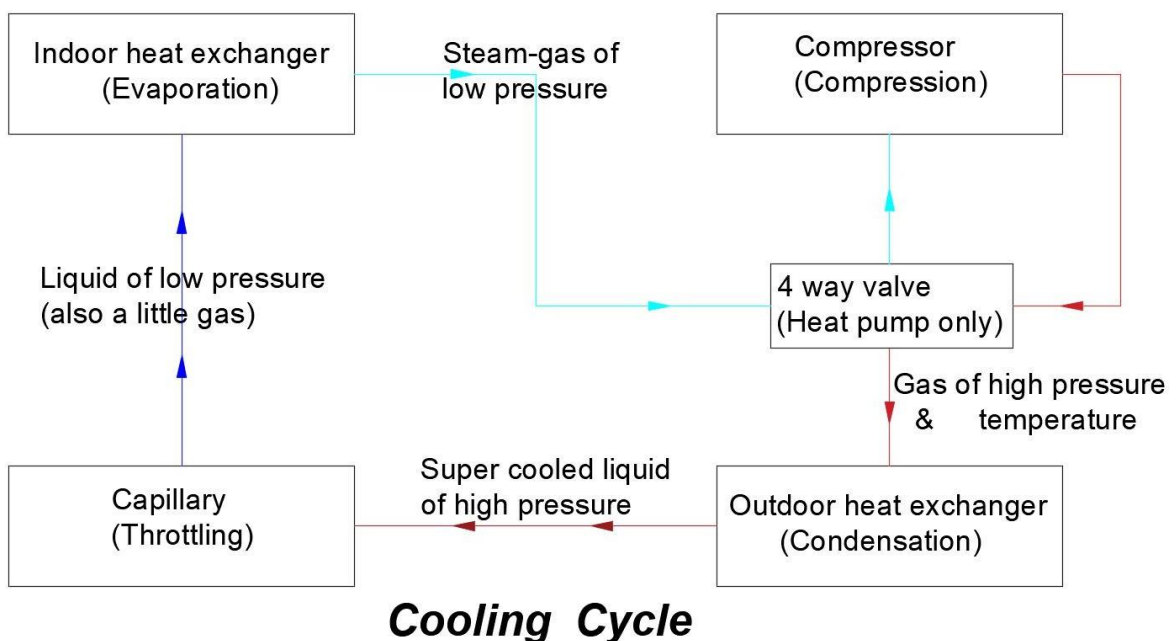
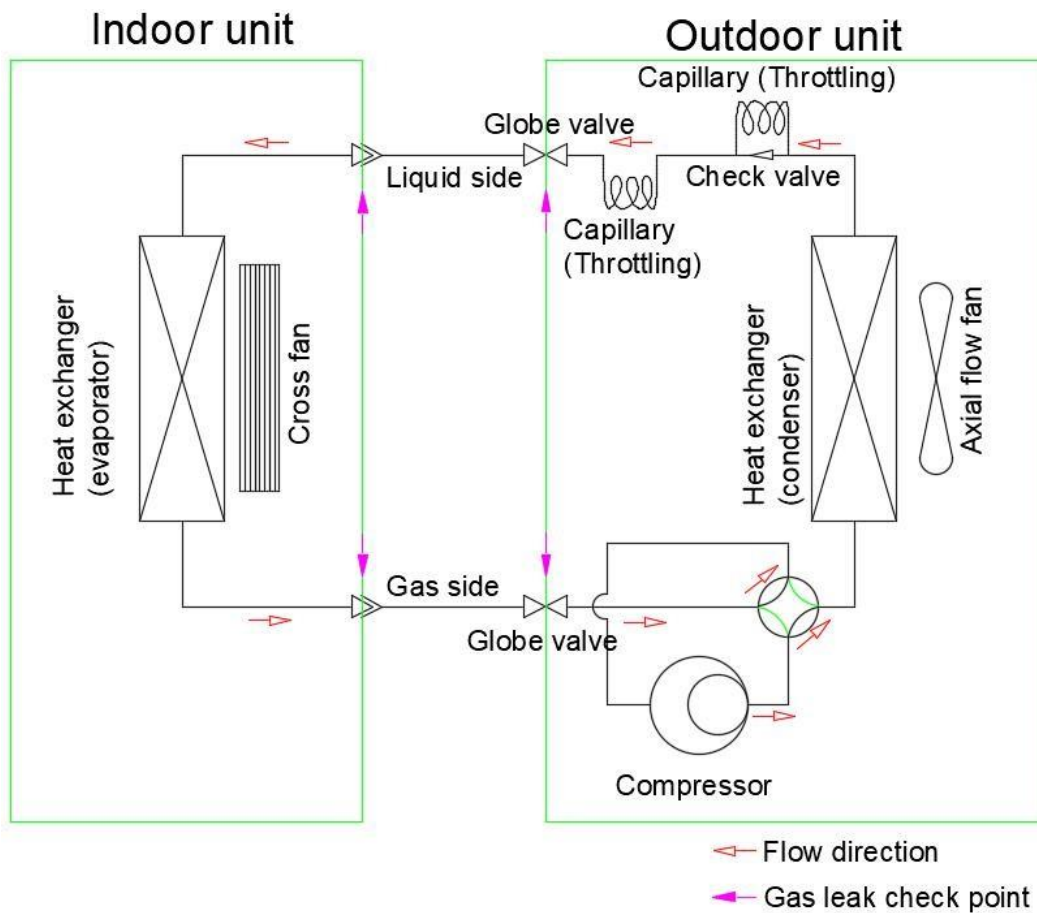

Heating Mode

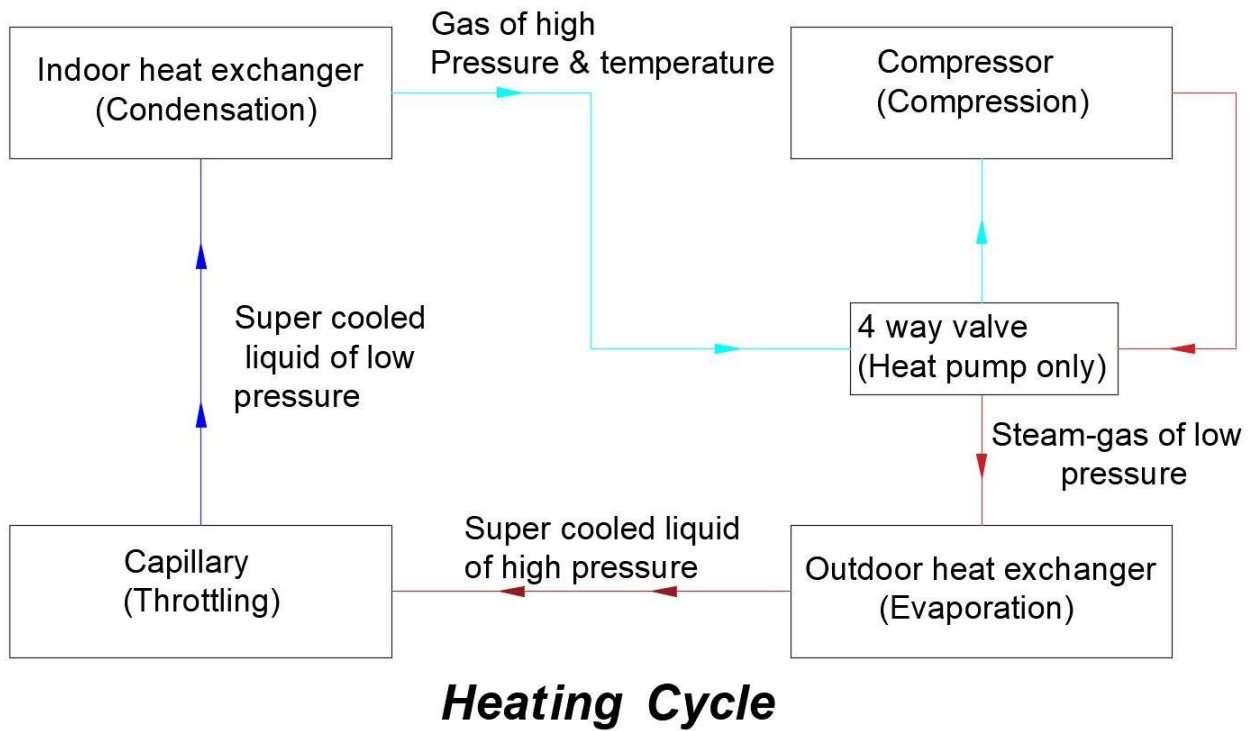
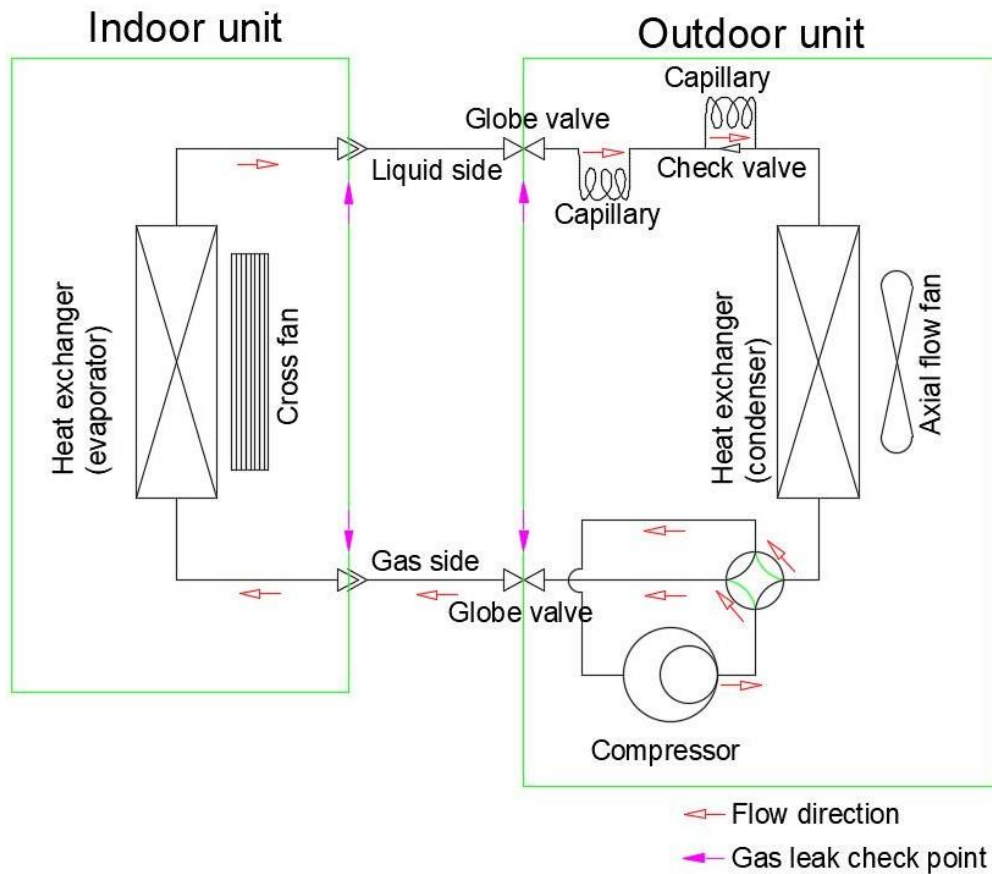

Chapter 3 Wiring Diagram

Description: The wiring diagram in this document is for reference only. Please refer to the wiring diagram provided on the product.

Indoor unit

Electric chart for XG-EF21RHA/XG-EF27RHA/XG-EF35RHA/XG-EF50RHA/XG-EF70RHA

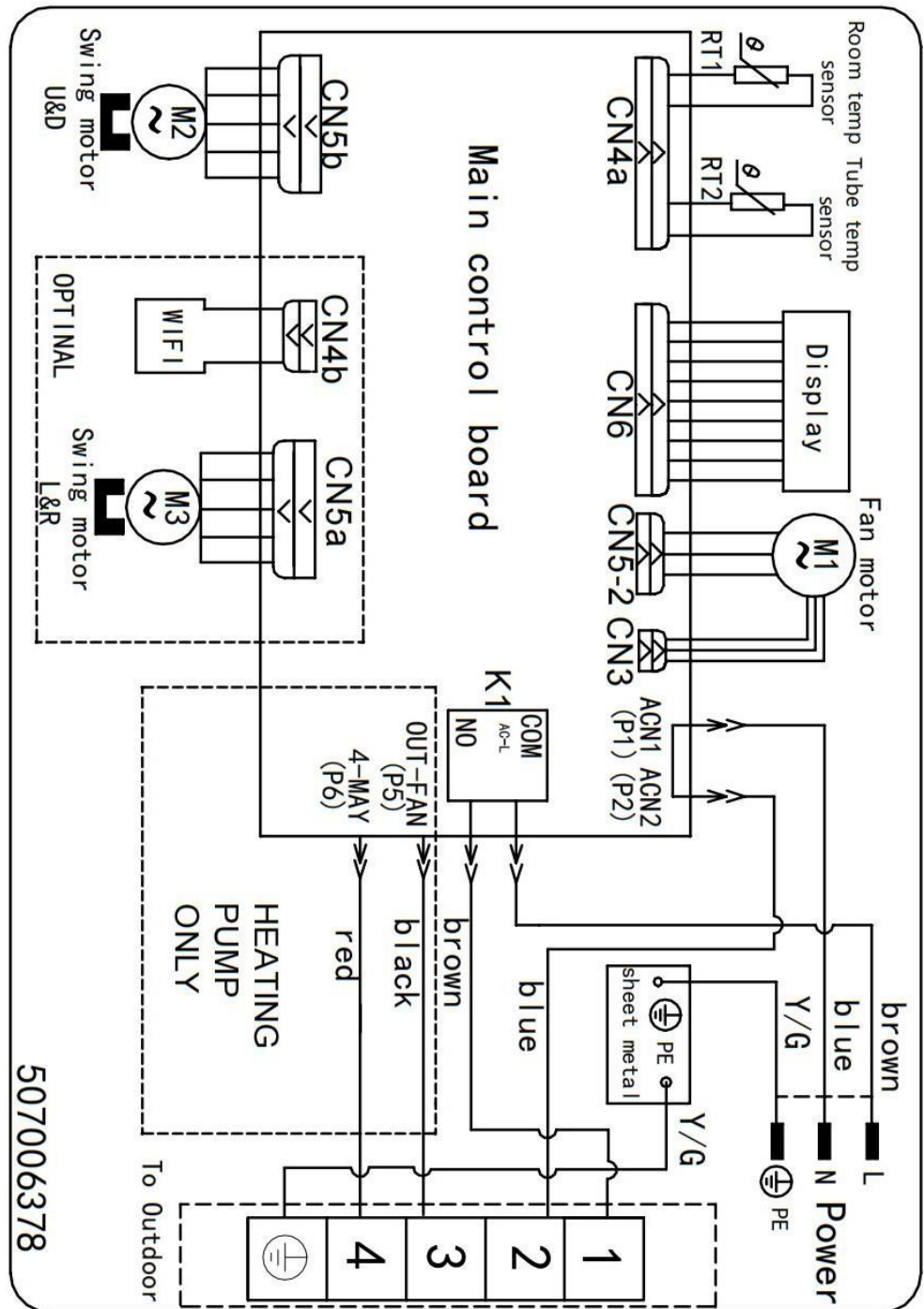

Outdoor unit

Electric chart for XG-EF21RHA/ XG-EF27RHA/ XG-EF35RHA

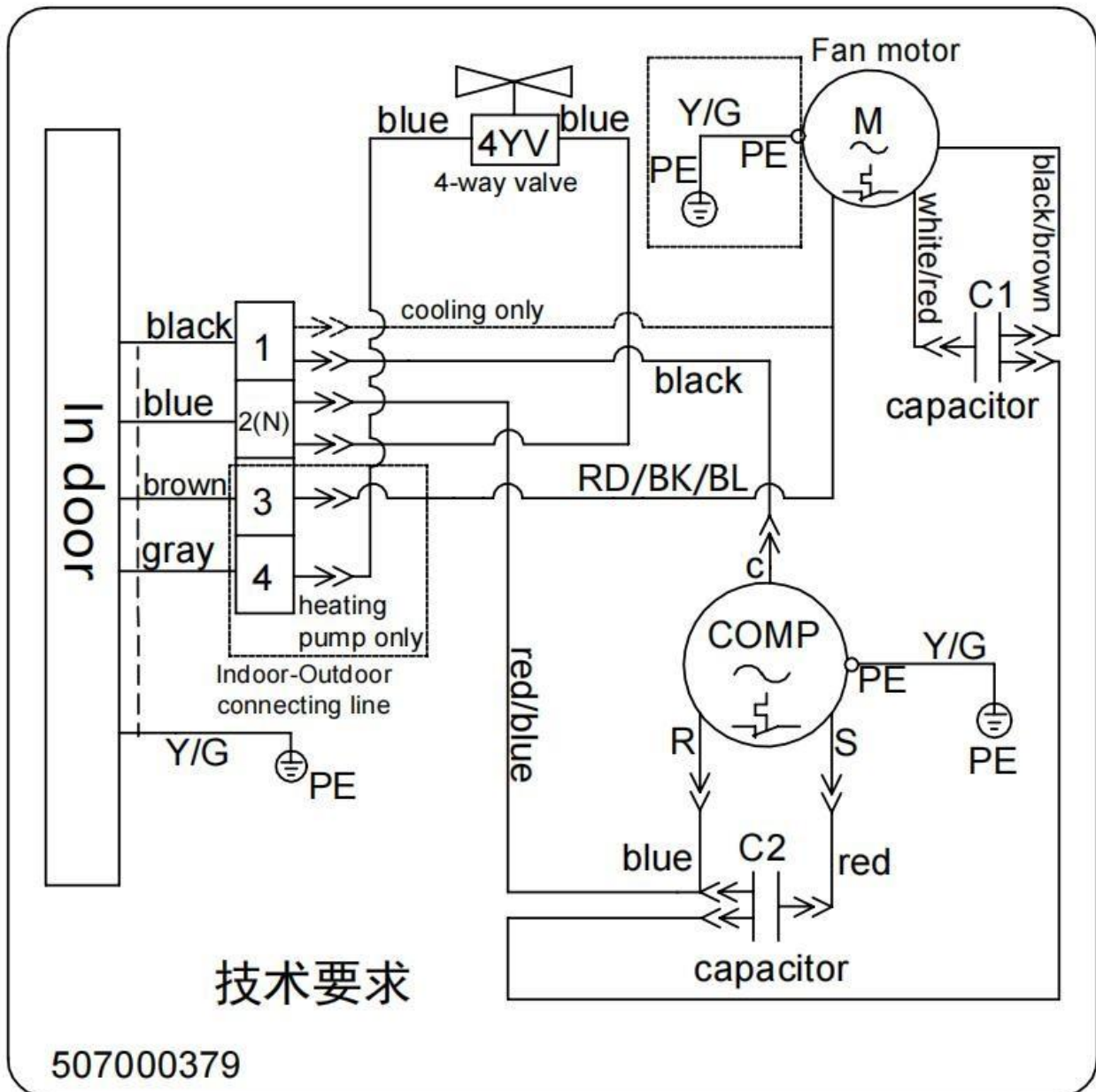

Electric chart for XG-EF50RHA

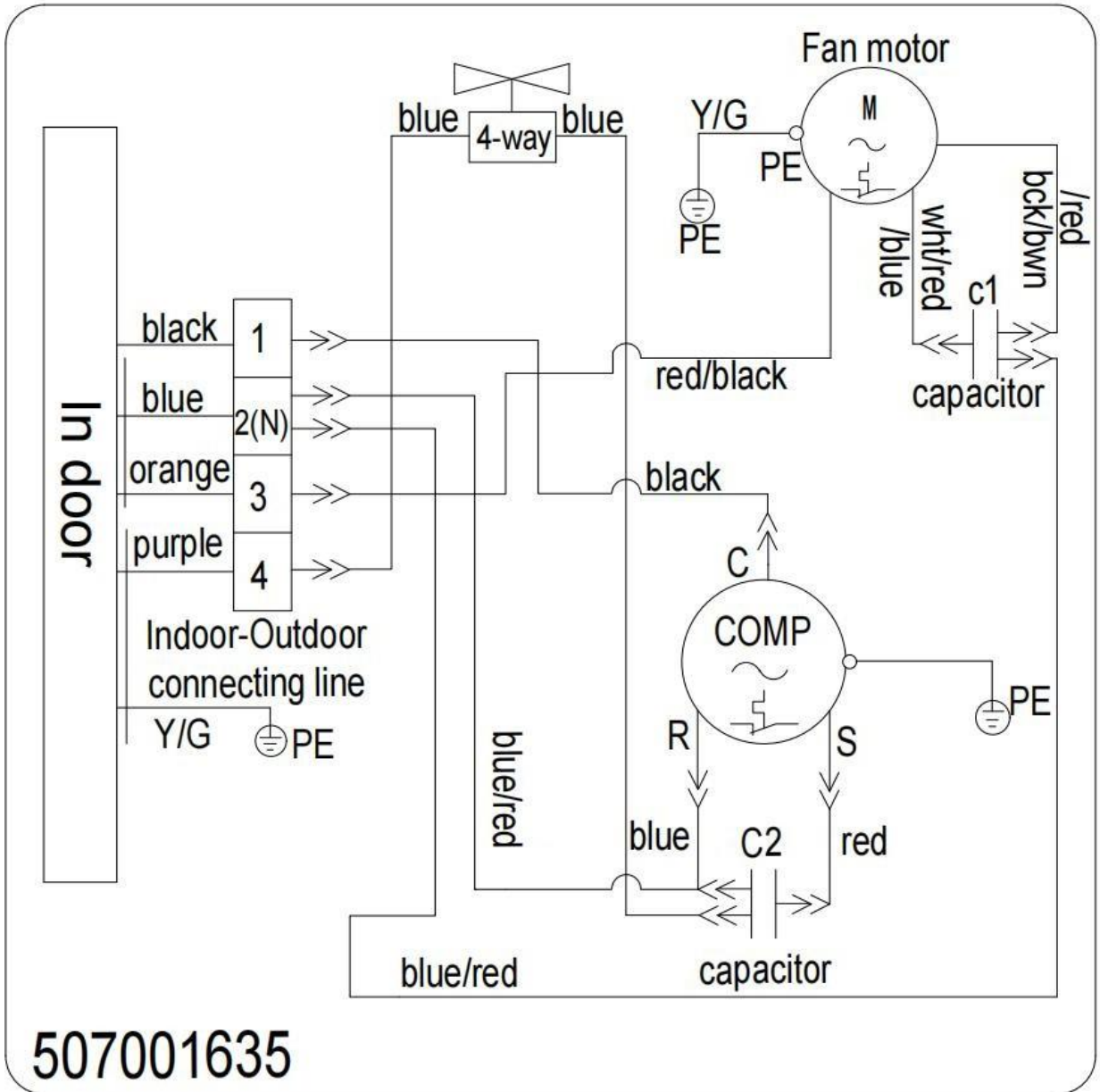

Electric chart for XG-EF70RHA

507004400

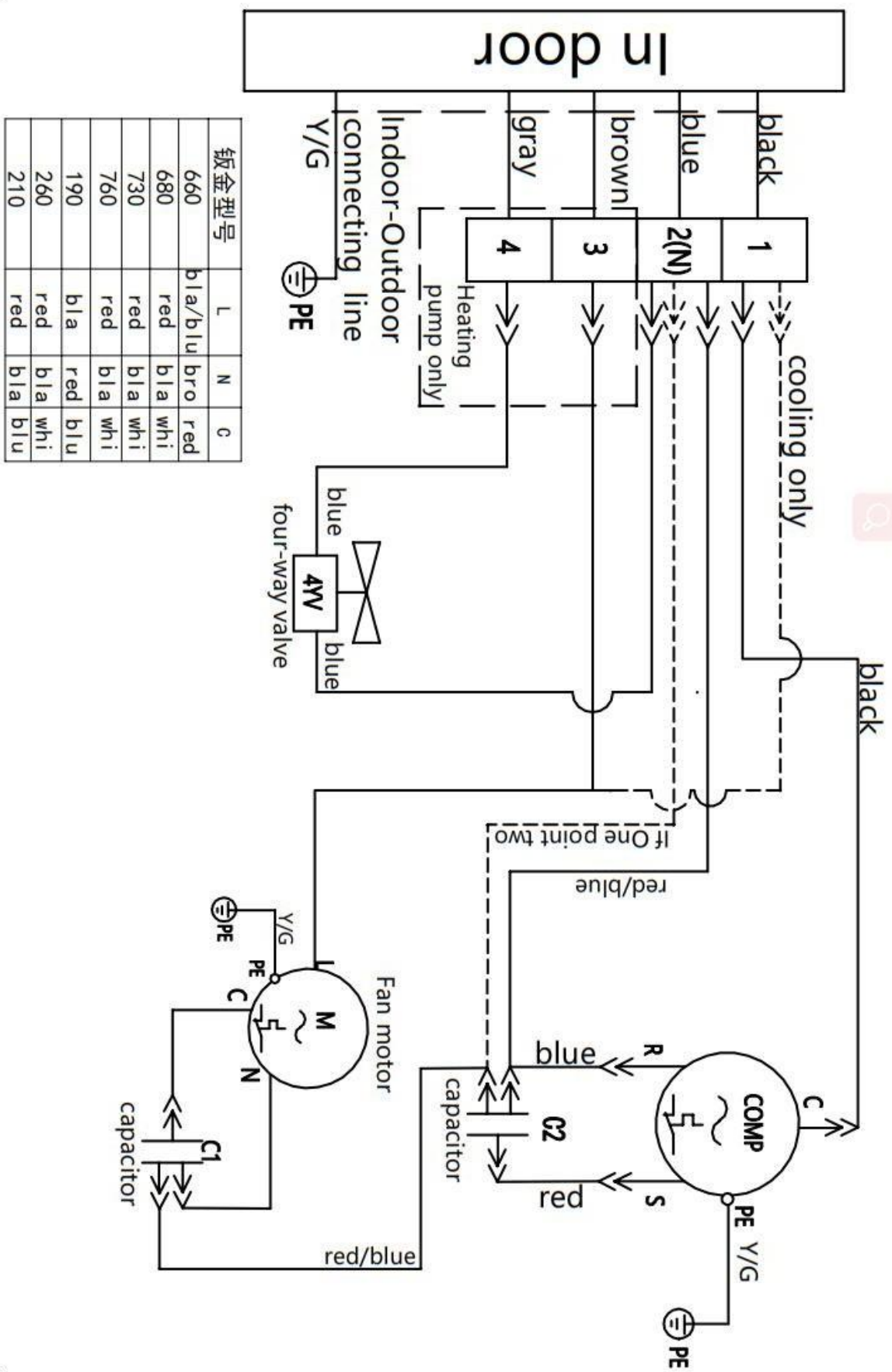

钣金型号	L	N	C
660	bla/blu	bro	red
680	red	bla	whi
730	red	bla	whi
760	red	bla	whi
190	bla	red	blu
260	red	bla	whi
210	red	bla	blu

Chapter 4 Troubleshooting Guide

4.1 Error Code

Description	Display on panel	Reasons	Troubleshooting methods
Indoor Room temperature sensor	E2	Indoor Room temperature Sensor in short circuit or open circuit	<ol style="list-style-type: none"> 1. Check whether the indoor room temperature sensor is off; 2. If the connection is normal, use a multimeter to measure the resistance. It should be 5KΩ at 25°C, otherwise it may be short-circuited or broken. Please replace the sensor; 3. Replace the indoor electric control board.
Indoor Coil temperature Sensor	E3	Indoor Coil temperature Sensor in short circuit or open circuit	<ol style="list-style-type: none"> 1. Check whether the indoor tube temperature sensor is off; 2. If the connection is normal, use a multimeter to measure the resistance. It should be 5KΩ at 25°C, otherwise it may be short-circuited or broken. Please replace the sensor; 3. Replace the indoor electric control board.
Outdoor Coil temperature sensor	E1	Outdoor Coil temperature Sensor in short circuit or open circuit	<ol style="list-style-type: none"> 1. Check whether the outdoor tube temperature sensor falls off; 2. If the connection is normal, use a multimeter to measure the resistance. It should be 5KΩ at 25°C, otherwise it may be short-circuited or broken. Please replace the sensor; 3. Replace the outdoor electrical control board.
Indoor fan error	E5	The fan of Indoor unit can not running or running unregularly	<ol style="list-style-type: none"> 1. Check whether the indoor motor wire and feedback wire are normal; 2. If the wiring is normal, the electric control board or motor may be damaged. Replace the indoor electric control board first, and then choose to replace the motor;
Defrost shows	DF	In the heating mode, when the outdoor ambient temperature is too low, it is a normal phenomenon.	

4.2 Troubleshooting Guide

4.2.1 The Foremost Inspecting Items

(1)The input voltage must be within +10% tolerance of the rated Voltage. If it is not the case, the air-conditioner will probably not work normally.

(2)Check the connecting cord between indoor unit and outdoor unit to see if it is properly connected. The connecting must be done according to the wiring diagram, please also notice that even different models may have the

connecting cord of the same specification.

Please check if the marks at the connecting terminal and the marks on the cord can match, otherwise, the air-conditioner will not work normally.

(3) If the following phenomena are found, the problem is not from the air-conditioner itself.

NO.	Problems	Causes
1	The motor is heard operating but the air-conditioner does not work when the indoor unit is powered on	Since the air-conditioner is powered on, it will come to working condition as long as you press the ON/OFF button of the remote control and the Signal is well received.
2	The compressor stops running but the indoor fan motor keeps working when it is at cooling mode with the indoor temperature higher than set temperature.	If you turn off the air-conditioner and restart it immediately, it will return to normal in 3 minutes, after that, the air-conditioner will automatically adjust the indoor fan speed to what you set.
3	The compressor works discontinuously at dehumidifying mode.	The air-conditioner will automatically control the working of the compressor according to the inside temperature.
4	The air-conditioner does not work while the LED display is on.	The TIMER is set with the air-conditioner; it will be in hold on condition. If the TIMER setting is cancelled, the air-conditioner will return to normal working condition.
5	The compressor works discontinuously at cooling and dehumidifying mode, and the indoor fan motor slows down.	The compressor stops internally or the fan motor slows down to prevent the indoor heat exchanger from being frozen.

4.2.2. No Power Display

(1) Items

a) Check if the input voltage is correct?

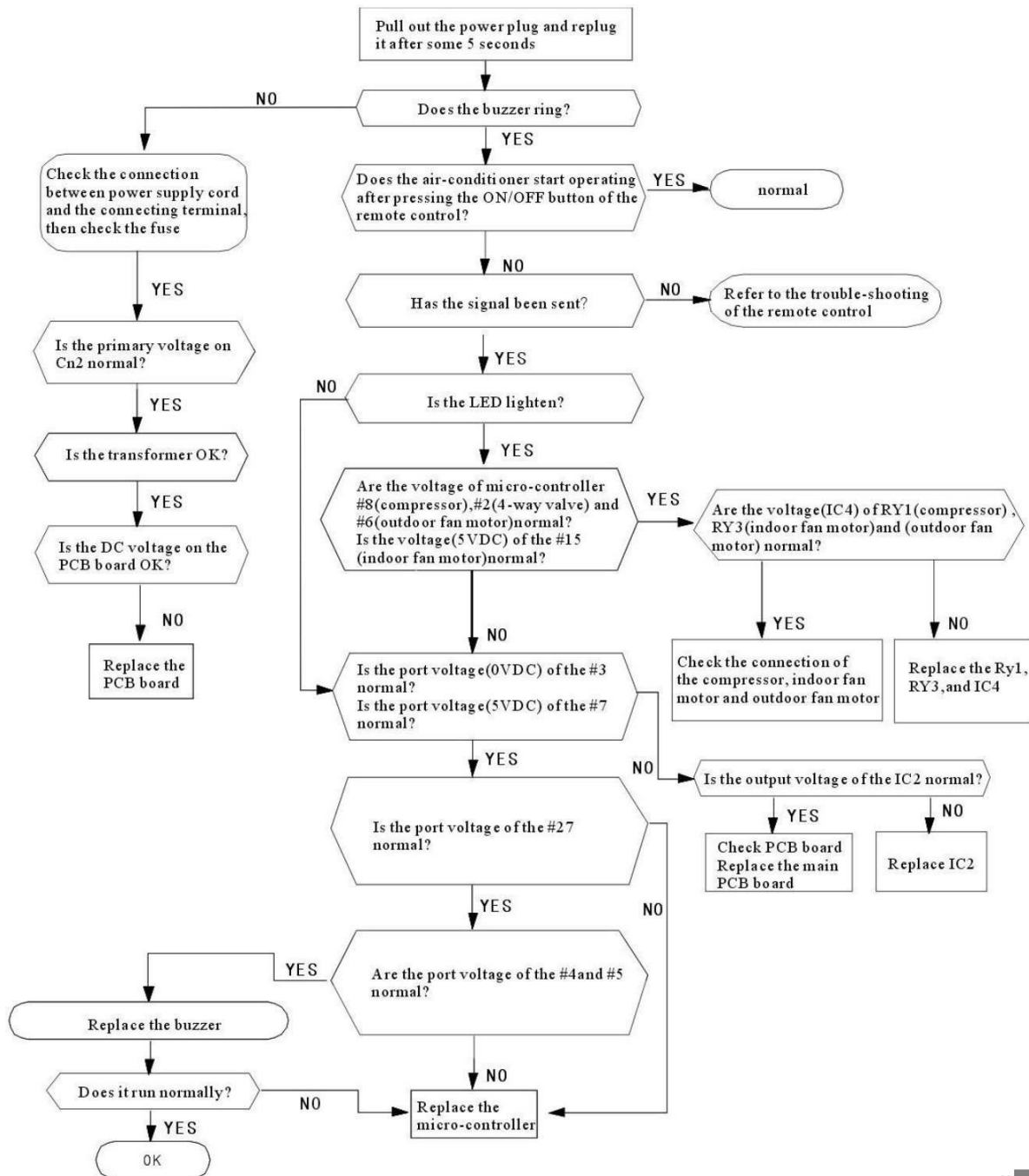

b) Check if the AC power supply connecting is correct?

c) Check if the output voltage of the manostat L7805 (IC2) is correct?

(2) Trouble shooting procedure

4.2.3. The Indoor Fan Motor Does Not Work

(1) Items

a) Check if the indoor fan motor is connected correctly to the connector (CN8)?

b) Check if the AC input voltage is correct?

c) Check if the IC of indoor fan motor is connected correctly to the connector (CN2)?

d) Check if the capacity of indoor fan motor is connected correctly to the connector (CN8)?

(2) Trouble shooting procedure

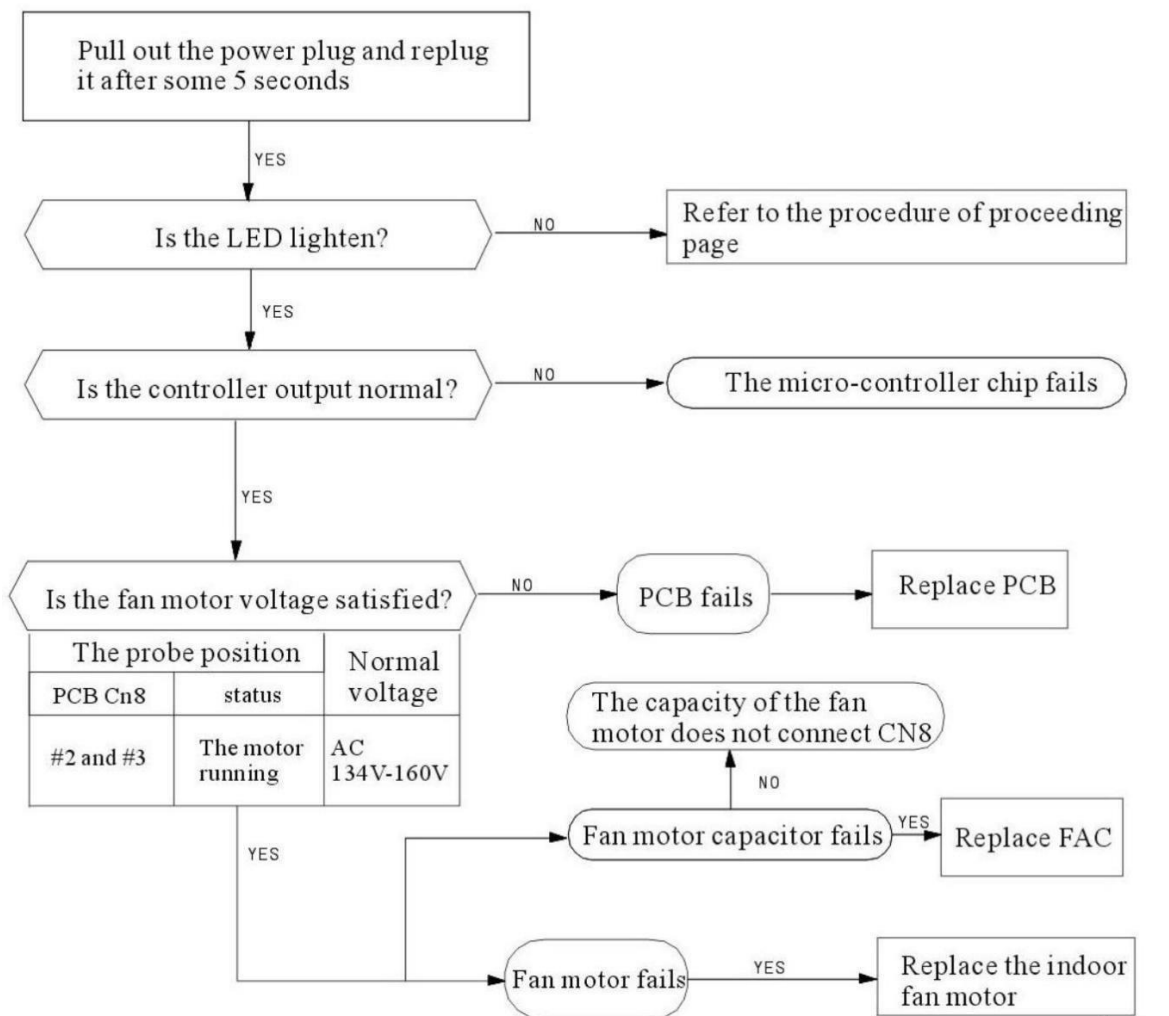

4.2.4 The Outdoor Unit Does Not Work

(1)Items

a) Check if the input voltage is correct?

b) Check if the wire connection of the outdoor connecting terminal is correct?

(2)Trouble shooting procedure

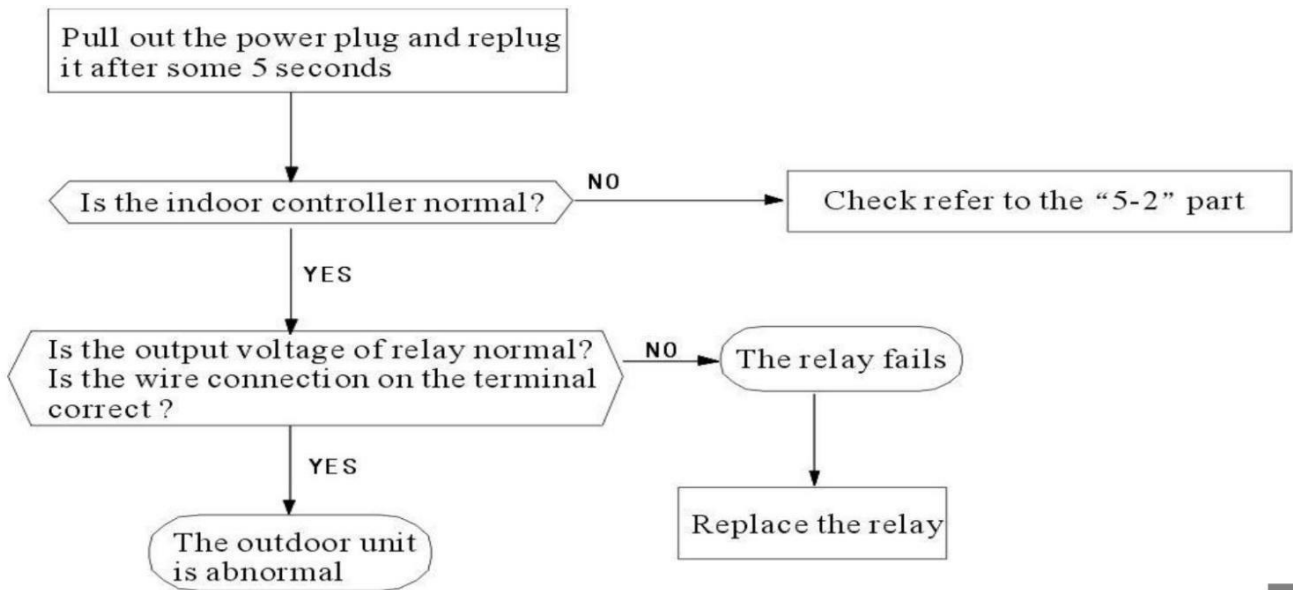

4.2.5 The Step Motor Does Not Work

(1)Items

a) Check if the input voltage is correct?

b) Check if the step motor controlling the up-down movement firmly connected to Cn2?

(2)Trouble shooting procedure

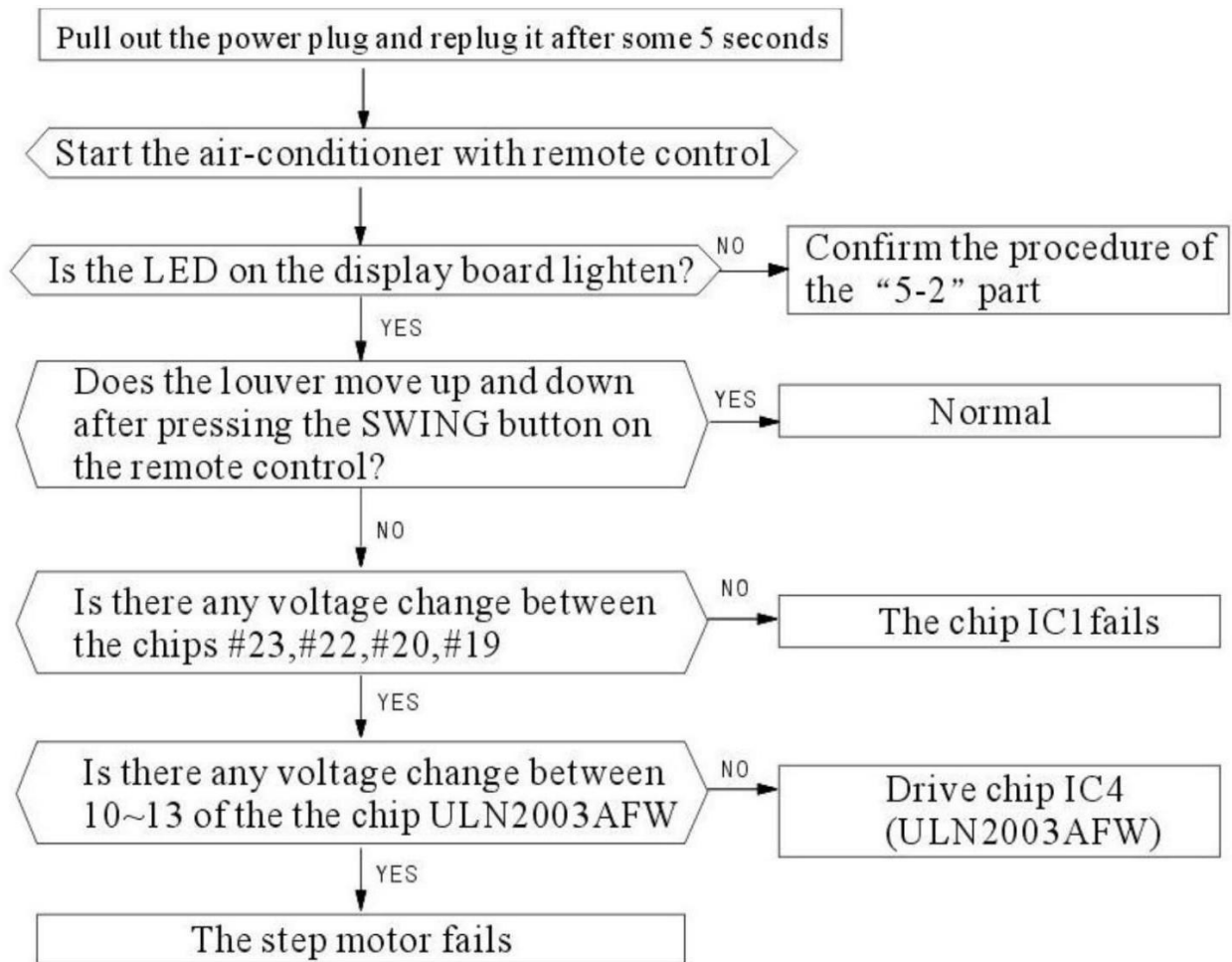

4.2.6 Remote Control Can Not Work

Trouble shooting rocedure

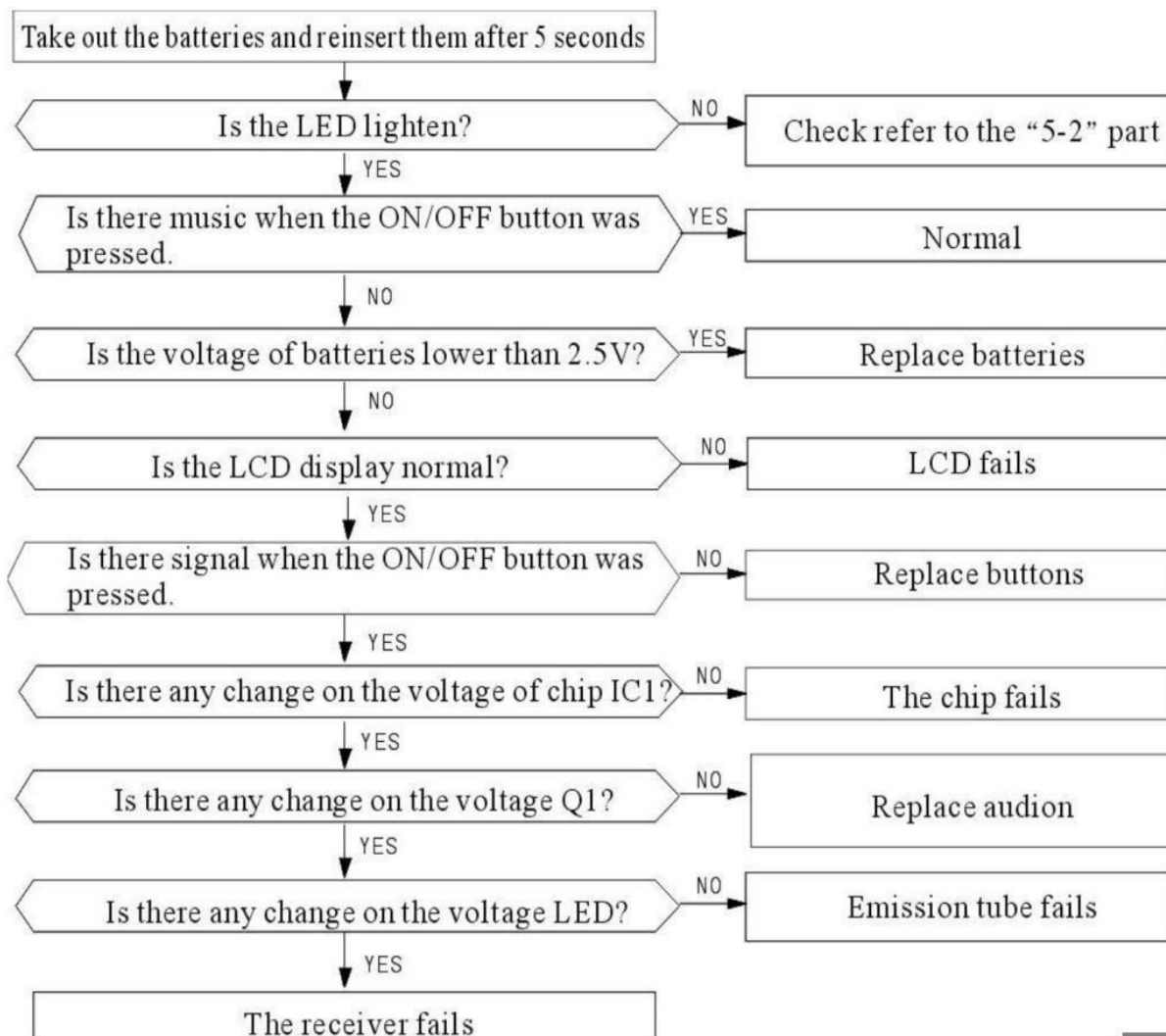

Chapter 5 Operation characteristic curve

5.1 Performance curve(ASHRAE)

Operating frequency: 60Hz

5.1.1 BSS-FR07-001、

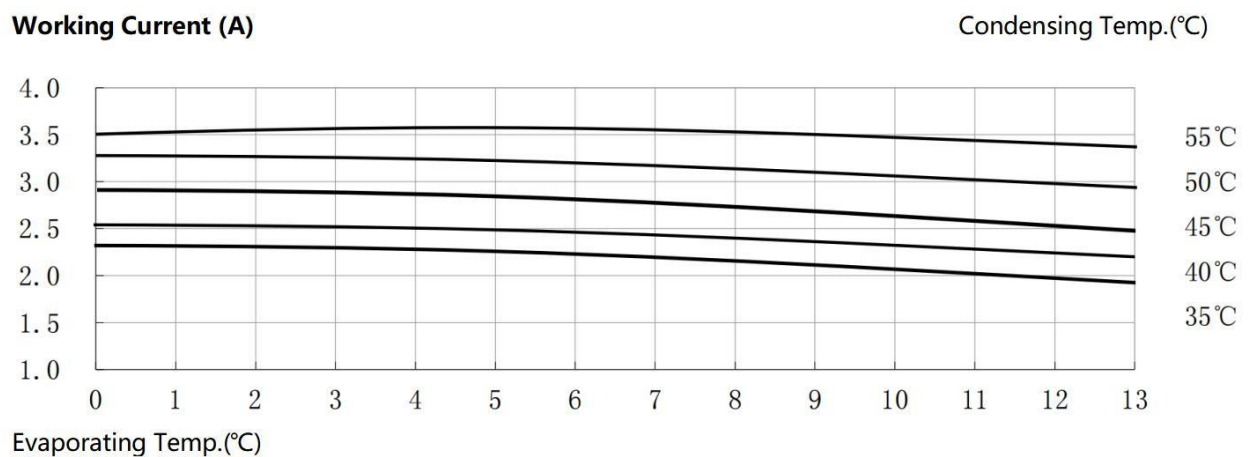
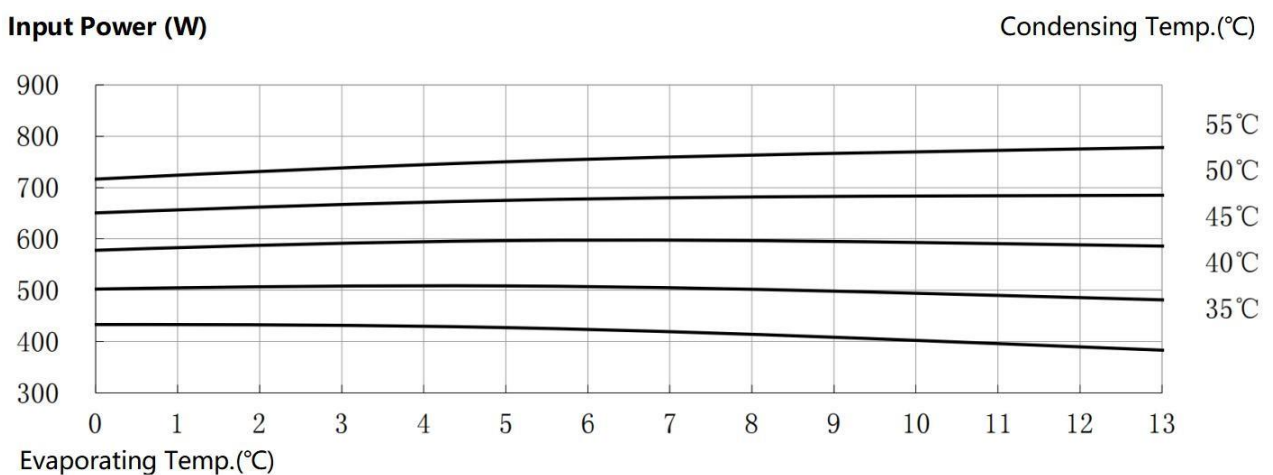
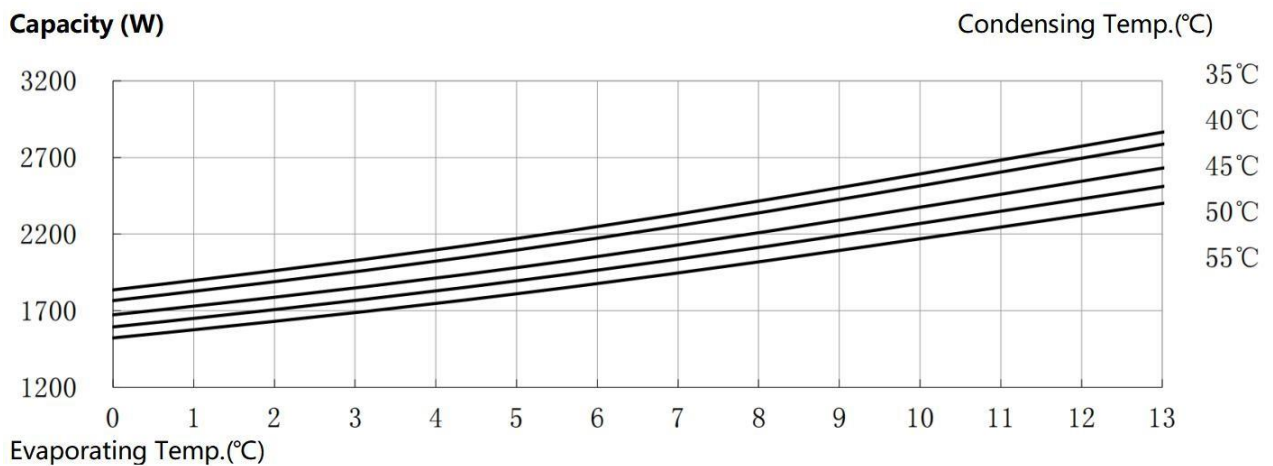

5.1.2 BSS-FR09-001

Capacity(w)

Condensing Temp.

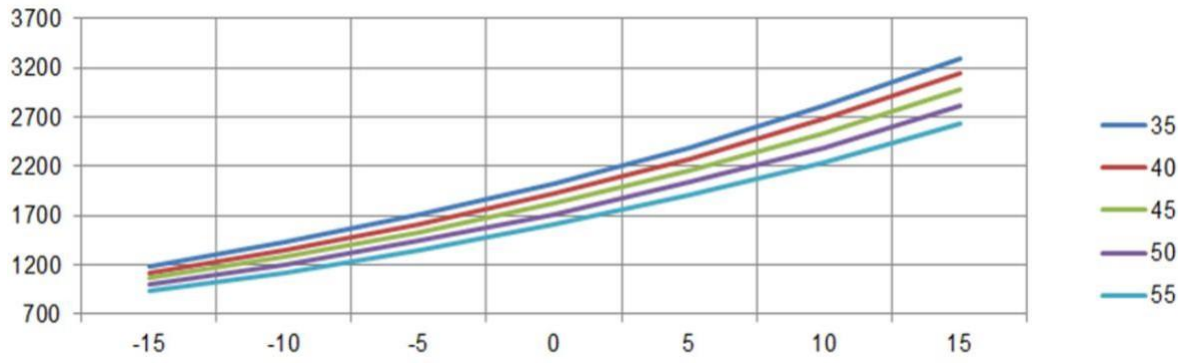

Input Power (w)

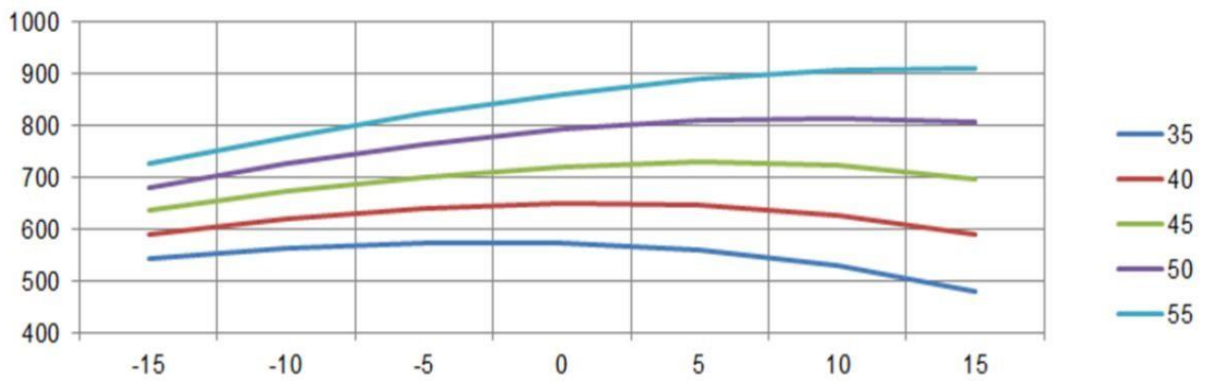

Working Current(A)

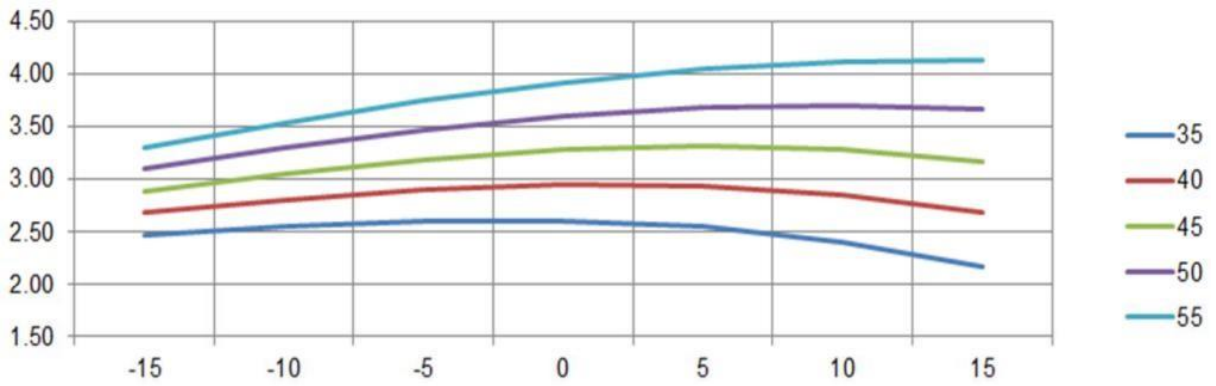

Evaporating Temp.(°C)

5.1.3 BSS-FR12-001

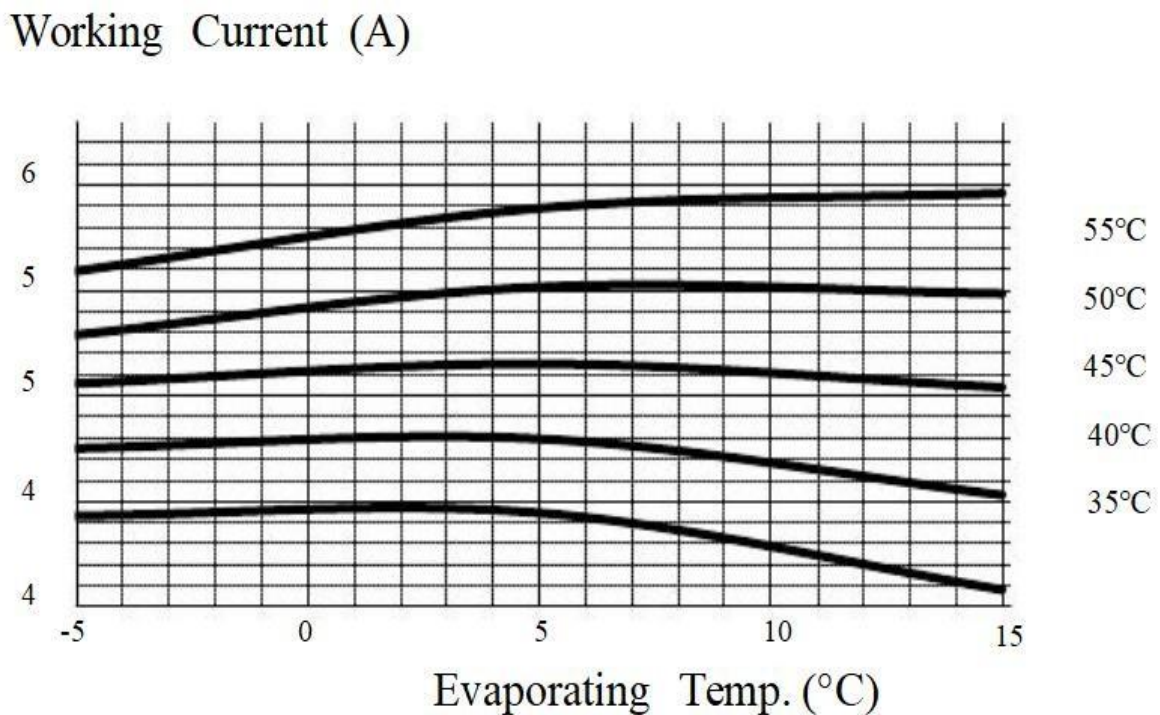
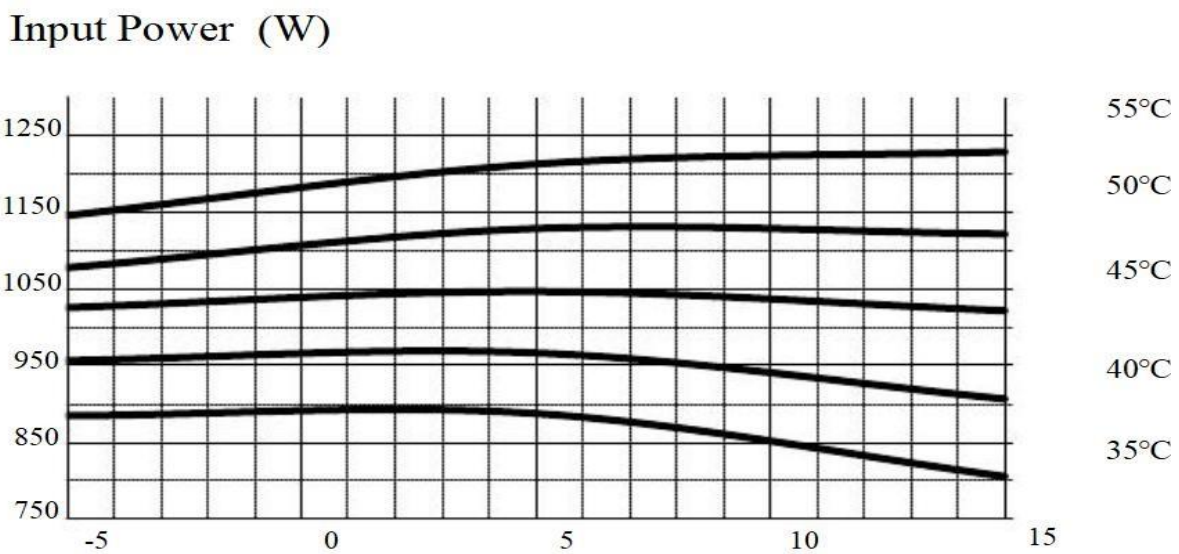
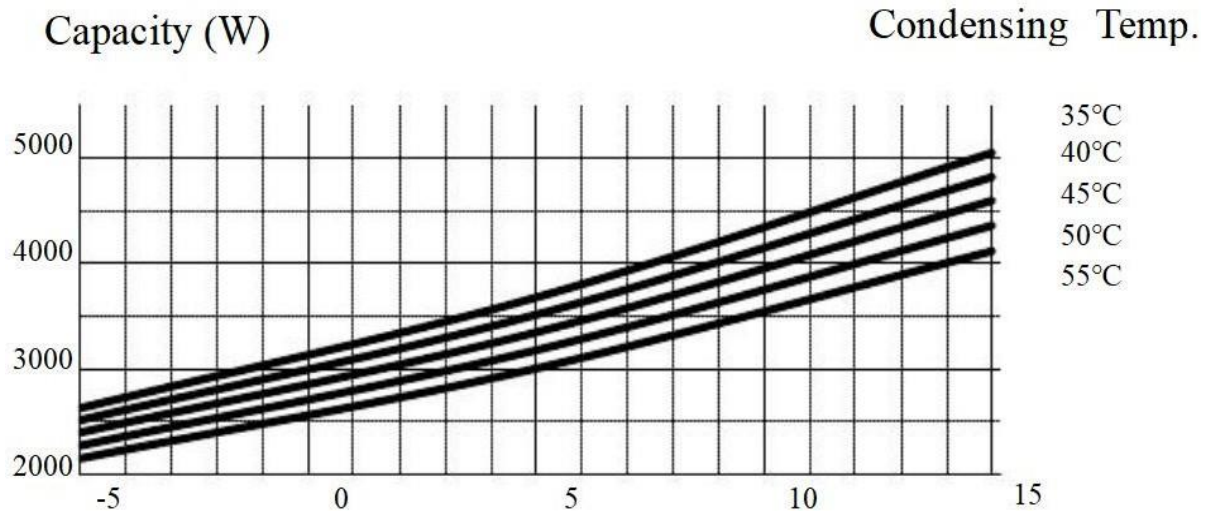

5.1.4 BSS-FR18-001

SHEC AIR CONDITIONING COMPRESSOR

GSH190TV-****L

50Hz 220V

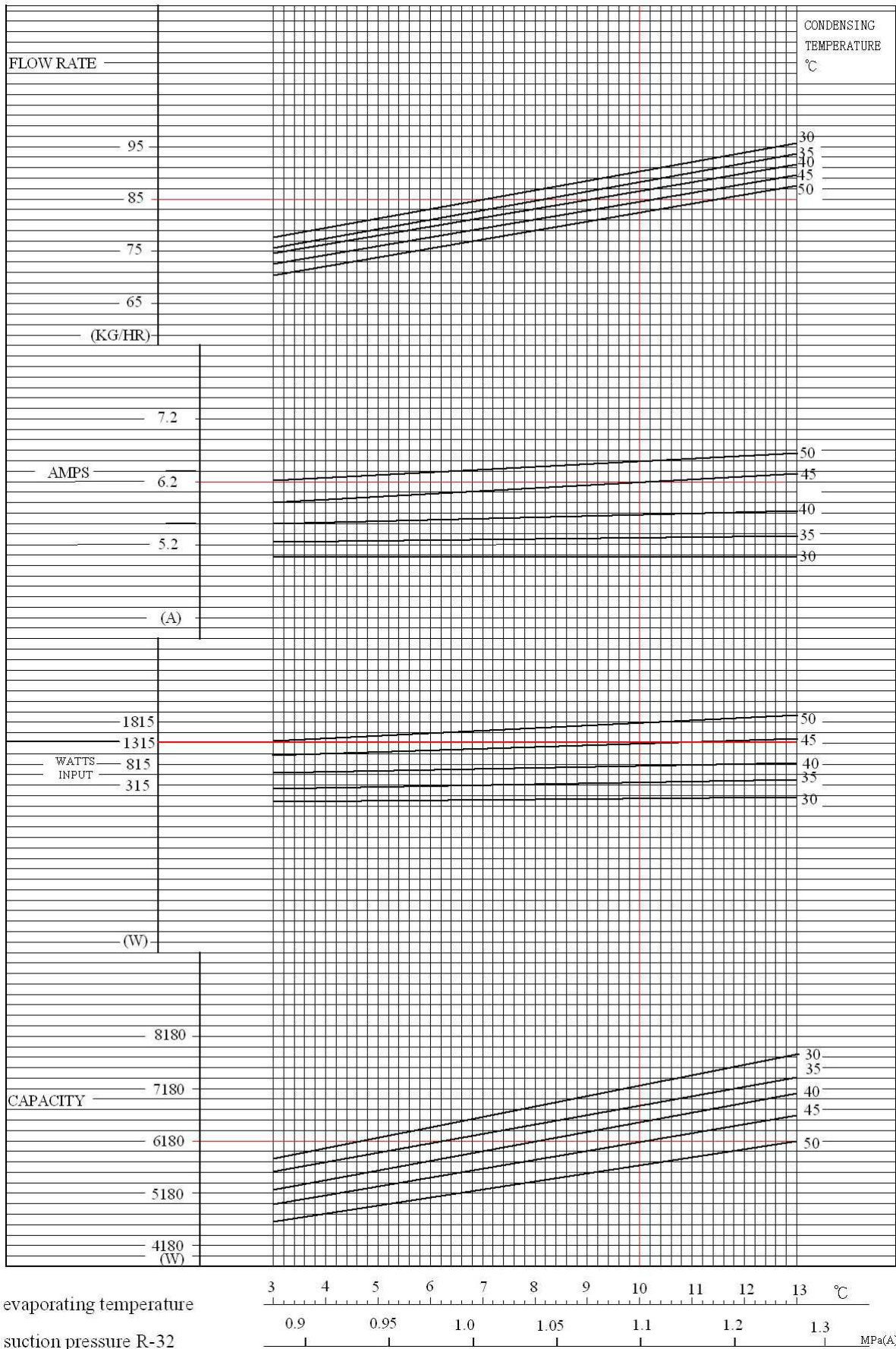

5.1.5 BSS-FR24-001

SHEC AIR CONDITIONING COMPRESSOR
ASL242SV-C7EQ

50Hz 220V-240V~

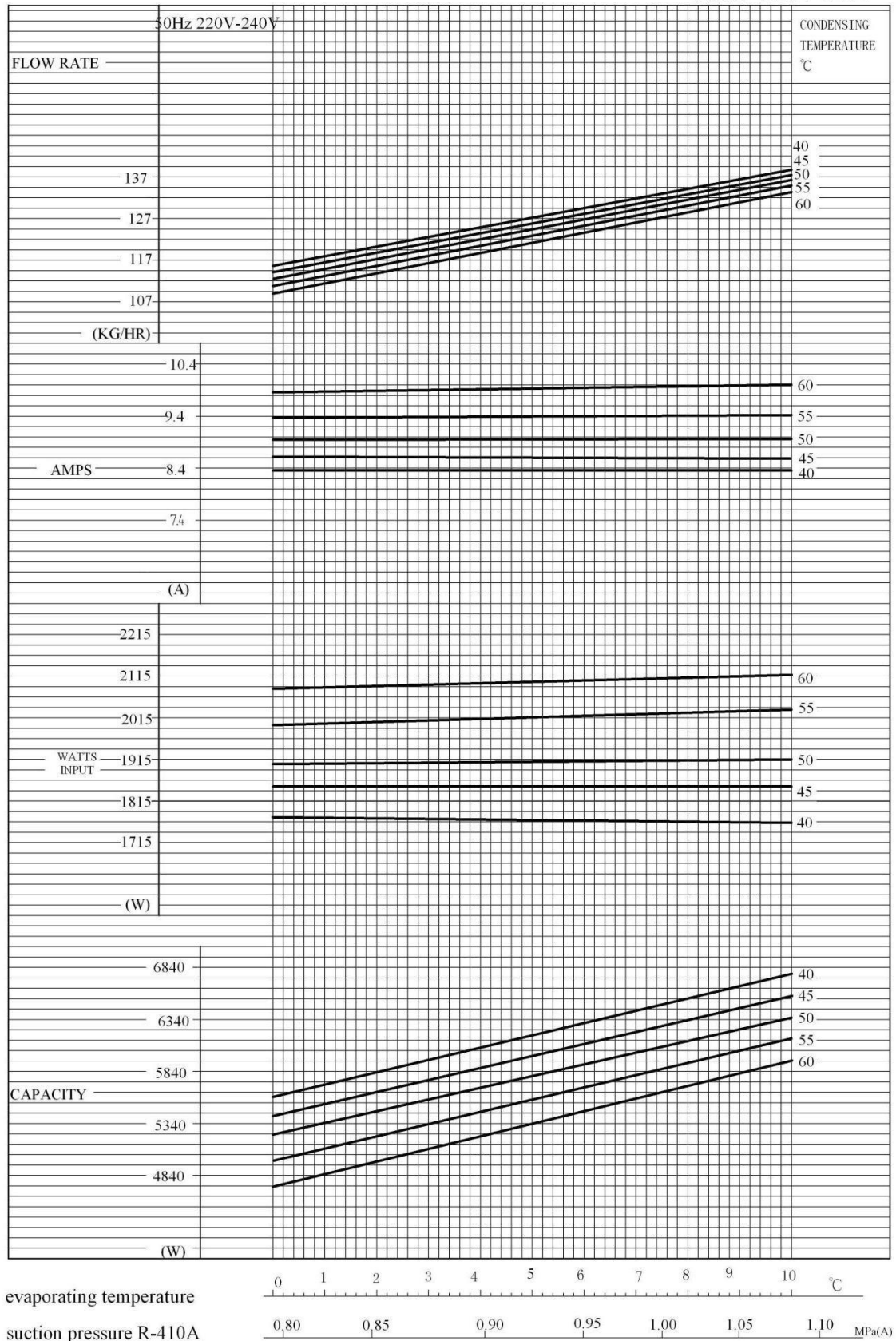

evaporating temperature
suction pressure R-410A

0 1 2 3 4 5 6 7 8 9 10 °C
0.80 0.85 0.90 0.95 1.00 1.05 1.10 MPa(A)

Chapter 6 Brier description

6.1 Brier description of modes and functions

There are 5 operating modes: automatic mode, air supply, refrigeration, dehumidification and heating.

6.1.1 Automatic mode

1. The set temperature range: 16°C-32°C
2. Press the "emergency button" or use the remote control to set the button in the automatic operation mode, and the air conditioner will enter the automatic operation mode with the default setting temperature of 25°C.
3. After entering the automatic mode, the internal fan runs at low wind for 20 seconds, and then the system determines the operation mode according to the indoor temperature.

Room temperature	$Tr < 21^{\circ}\text{C}$	$21^{\circ}\text{C} \leq Tr \leq 26^{\circ}\text{C}$	$26^{\circ}\text{C} < Tr$
Running mode	Heating	Fan	Cooling

4. Once the operation mode is determined, the mode will no longer change with the indoor temperature. When the user automatically changes to other modes at this time, the compressor has 3 minutes of shutdown protection.

6.1.2 Cooling mode

1. The set temperature range: 16°C-32°C

2. Working condition of press:

In refrigeration mode, the temperature control curve of the compressor is shown as follows:

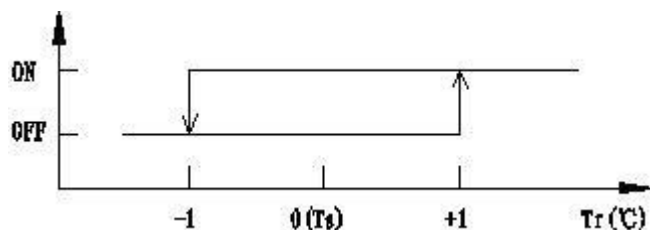

3. Working condition of external fan:

In refrigeration mode, the external fan is synchronized with the press.

4. Four-way valve working conditions:

In refrigeration mode, the four-way valve is always closed.

6.1.3 DRY mode

1. The set temperature is displayed as "--" and remains unchanged

2. Working condition of press:

In the drying mode, the internal fan will first run at low air for 20s, and the compressor will choose the working mode according to the indoor temperature, and the room temperature will be tested once every cycle:

- (1) When $TR \geq 23^{\circ}\text{C}$, run for 7 minutes and stop for 5 minutes.

(2) When $T_r < 23^\circ\text{C}$, run for 5 minutes and stop for 7 minutes.

When $T_r \leq 10^\circ\text{C}$, the system is prohibited from running, except the internal fan and display screen.

3. The external fan working condition: drying mode, the external fan and compressor synchronization.

4. Working condition of internal fan: in dry mode, internal fan always runs at low wind and can not be adjusted.

5, the four-way valve working condition: in the dry mode, the four-way valve has been closed.

6. Working condition of the outer air door piece: in the dry mode, the outer air door piece is in the "anti-cold wind, anti-mildew Angle" and can not be adjusted.

7, dry mode without strong function.

6.1.4 Heating mode

1, the set temperature range: 16°C - 32°C

2. Working condition of press:

In heating mode, the temperature control curve of the compressor is shown as follows:



Working condition of external fan:

(1) The non-defrosting state and overload, outside the fan and press synchronization.

When defrosting, the outside fan runs according to the requirements of defrosting.

4. Working condition of internal fan:

High wind, stroke, low wind and automatic wind operation can be set in the heating mode.

5, four-way valve working conditions:

(1) In the non-defrosting state, the four-way valve has been in the open state.

The defrosting operation, the four-way valve according to the defrosting work requirements.

(3) When the heating compressor is closed, the four-way valve is delayed for two minutes.