

TECHNICAL & SERVICE MANUAL V3.3

—DC INVERTER AIR CONDITIONERS

MODEL:

AUD-18UX4SGKL
AUD-24UX4SZLH
AUD-36UX4SAMH
AUD-48UX6SPHH
AUD-60UX6SPHH

AUV-18UR4SZA1
AUV-24UR4SAA1
AUV-36UR4SAB1
AUV-48UR6SPC
AUV-60UR6SPC

AUD-18UX4SZKL1
AUD-24UX4SALH1
AUD-36UX4SAMH1

AUC-18UX4SGAA
AUC-24UX4SZEAA
AUC-36UX4SAEA
AUC-48UX6SPFA
AUC-60UX6SPFA

AUC-18UR4SZAA1
AUC-24UR4SAEA1
AUC-36UR4SAEA1

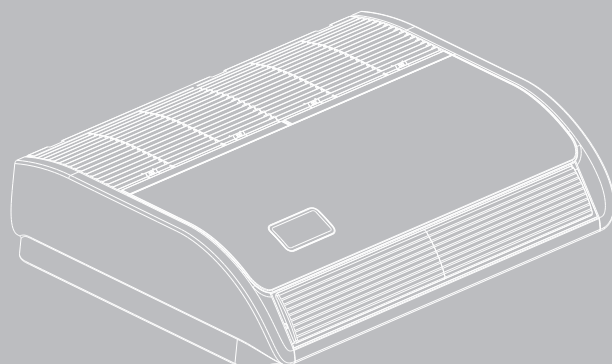
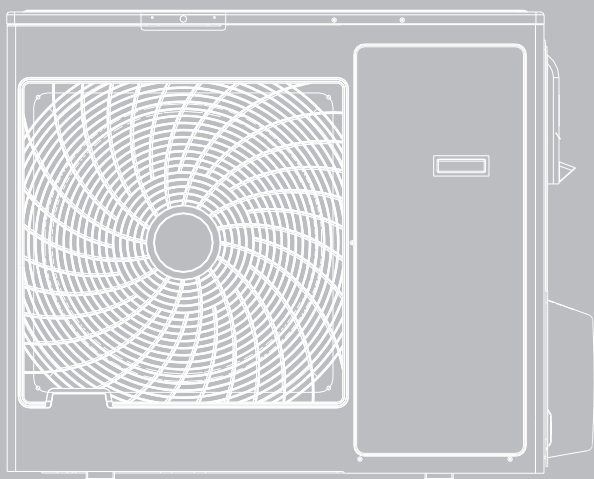
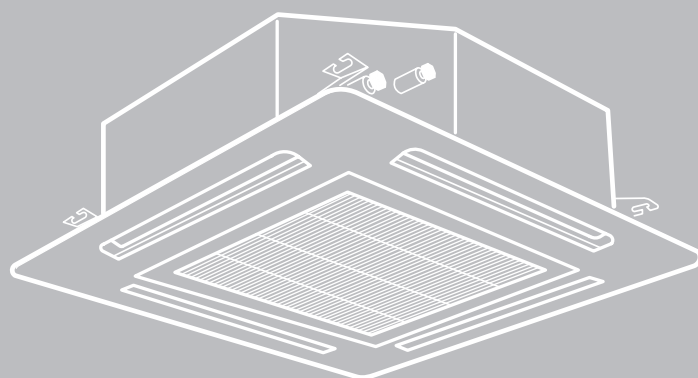
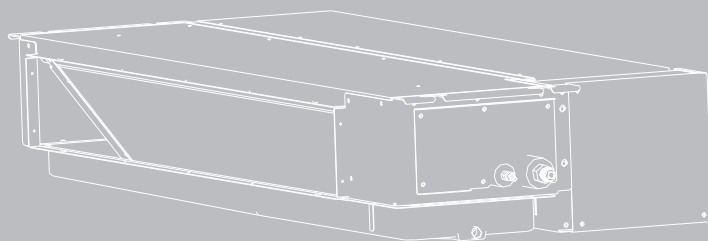

Table of Contents

	Page
1. GENERAL -----	1
2. SPECIFICATION -----	15
3. OUTLINES AND DIMENSIONS -----	24
3-1 INDOOR -----	24
3-2 OUTDOOR -----	29
4. DIAGRAM&DATA -----	33
4-1 Refrigerant Flow Diagram -----	33
4-2MAX. Refrigerant Pipe Length and Height Difference -----	36
4-3 Electric Diagrams -----	37
4-4Air flow and ESP Chart Diagrams(for duct type) -----	39
4-5 PERFORMANCE CURVE -----	44
5. ELECTRICAL DATA -----	44
5-1 Electric Wiring Diagrams -----	46
5-2. Electric Control -----	59
5-3. Dip Switch Setting of Outdoor -----	68
5-4. Digital Display Switch of Outdoor -----	69
5-5. Static Pressure Setting(only for duct type) -----	71
5-6. Internal Control Parameter Adaptation -----	72
5-7 Sensor Parameter -----	74
6. CONTROL MODE -----	82
6-1 Indoor Control Mode -----	82
6-2 Outdoor Control Mode -----	85
7. TROUBLE SHOOTING -----	87
7-1 Error Codes -----	87
8. CHECKING COMPONENTS -----	116

8-1 Check Refrigerant System -----	110
8-2 Check Parts Unit -----	112

1. GENERAL

1.1 Features

Duct Type Air Conditioner



Features

➤ **Save Installation Space**

The indoor unit can be installed inside the ceiling conveniently.

➤ **Optional Static Pressure**

18k: optional 10Pa /30Pa, 24K/36K 50Pa/80Pa(For AUD-24UX4SALH1&AUD-36UX4SAMH1 , freely changed between1-80Pa), 48K/60K: 80Pa/120Pa static Pressure.

One unit, mute optional installation method.

➤ **High Efficiency and Environment Friendly New Refrigerant-R410A**

R410A can protect the environment and do not harm to the ozone layer.

➤ **24-hour Timer ON and OFF**

This Timer can be set to automatically turn the unit on or off within a 24-hour period.

➤ **Mute Operation**

The excellent fan design enable the airflow to be quiet and smooth with minimum noise.

➤ **Meeting Various Installation Requirements**

The back-air-inlet type is usually to be adopted according to the actual installation space.

The unit is also installed with down-air-inlet type and the noise will increase about 5-6

1. GENERAL

dB.

➤ **Self Recovery of Power Break**

When the power supply is recovered after break, all preset are still effective and the air-conditioner can run according to the original setting.

➤ **Fault Self-diagnose Function**

When there is something wrong with the air-conditioner , the micro computer could diagnose the faults, which can be read from the display and is convenient for maintenance.

1. GENERAL

Cassette Type Air Conditioner



Features

➤ **Save Installation Space**

The indoor unit can be installed inside the ceiling conveniently.

➤ **High Efficiency and Environment Friendly New Refrigerant-R410A**

R410A can protect the environment and do not harm to the ozone layer.

➤ **24-hour Timer ON and OFF**

This Timer can be set to automatically turn the unit on or off within a 24-hour period.

➤ **Mute Operation**

The excellent fan design enable the airflow to be quiet and smooth with minimum noise.

➤ **Self Recovery of Power Break**

When the power supply is recovered after break, all preset are still effective and the air-conditioner can run according to the original setting.

➤ **Fault Self-diagnose Function**

When there is something wrong with the air-conditioner, the micro computer could diagnose the faults, which can be read from the display and is convenient for maintenance.

1. GENERAL

Ceiling & Floor Air Conditioner



Features

➤ **Save Installation Space**

The indoor unit's thickness is only 230mm, can be installed inside the ceiling conveniently.

➤ **Flexible Installation Options**

According to the actual installation space, The indoor unit can be installed in the ceiling or on the floor. One unit, Two installation method.

➤ **High Efficiency and Environment Friendly**

New Refrigerant-R410A

R410A can protect the environment and do not harm to the ozone layer.

➤ **24-hour Timer ON and OFF**

This Timer can be set to automatically turn the unit on or off within a 24-hour period.

➤ **Mute Operation**

The excellent fan design enable the airflow to be quiet and smooth with minimum noise.

➤ **Various Refrigerant Pipe Connect Methods**

The refrigerant pipe can be connect from 3 different directions(rear, right or top) .More methods, more conveniently.

➤ **Self Recovery of Power Break**

When the power supply is recovered after break, all preset are still effective and the air-conditioner can run according to the original setting.

1. GENERAL

➤ Fault Self-diagnose Function

When there is something wrong with the air-conditioner, the micro computer could diagnose the faults, which can be read from the display and is convenient for maintenance.

1. GENERAL

1.2 Product Lineup

Type	Model	18	24	36	48	60
Duct Type	AUD-	●	●	●	●	●
Cassette Type	AUC-	●	●	●	●	●
Ceiling&Floor type	AUV-	●	●	●	●	●

1. GENERAL

1.3 MODEL IDENTIFICATION

A U C -18 U R 4 S Z A A 1

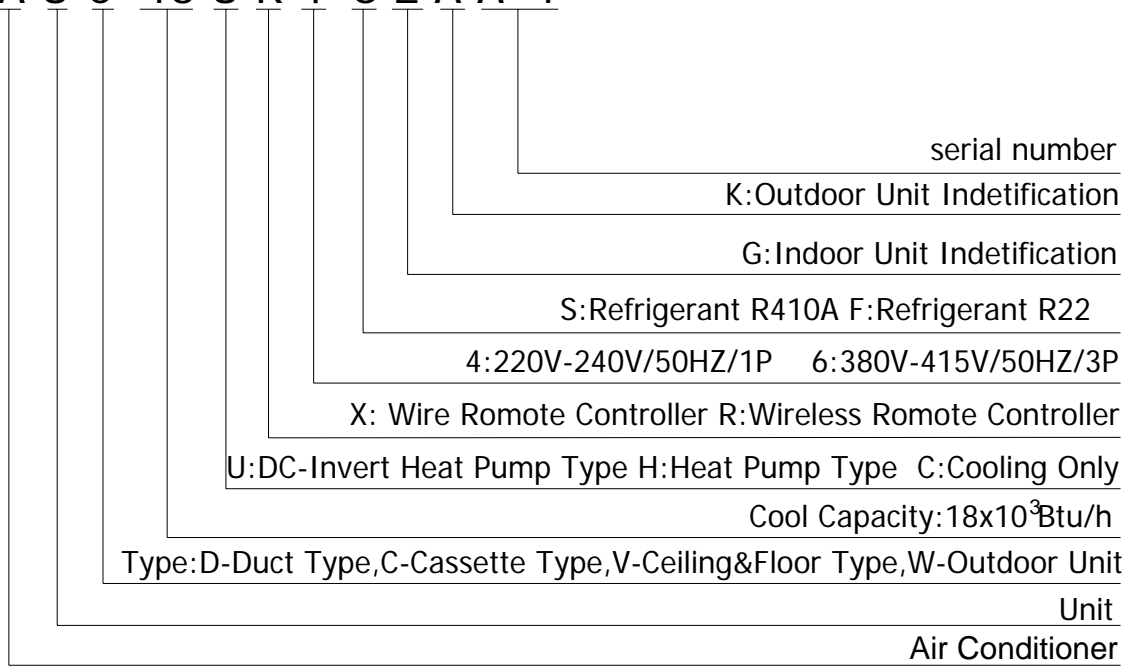

1. GENERAL

1.4 Product Picture

Duct Type

Model	AUD-18UX4SGKL	AUD-24UX4SZLH
Indoor		
Outdoor		
Model	AUD-36UX4SAMH	AUD-48UX6SPHH AUD-48UX6SPHH
Indoor		
Outdoor		

1. GENERAL

Model	AUD-18UX4SZKL1	AUD-24UX4SALH1
Indoor		
Outdoor		
Model	AUD-36UX4SAMH1	
Indoor		
Outdoor		

1. GENERAL

Cassette Type







Model	AUC-18UX4SGAA	AUC-24UX4SZEZ
Indoor		
Outdoor		
Model	AUC-36UX4SABE	AUC-48UX6SPFA AUC-60UX6SPFA
Indoor		
Outdoor		

1. GENERAL

Model	AUC-18UR4SZAA1	AUC-24UR4SAEA1 AUC-36UR4SAEA1
Indoor		
Outdoor		

1. GENERAL

Ceiling & Floor Type

Model	AUV-18UR4SZA1	AUV-24UR4SAA1
Indoor		
Outdoor		
Model	AUV-36UR4SAB1	AUV-48UR6SPC AUV-60UR6SPC
Indoor		
Outdoor		

1. GENERAL

DISPLAY PANEL:

Cassette Type

18k

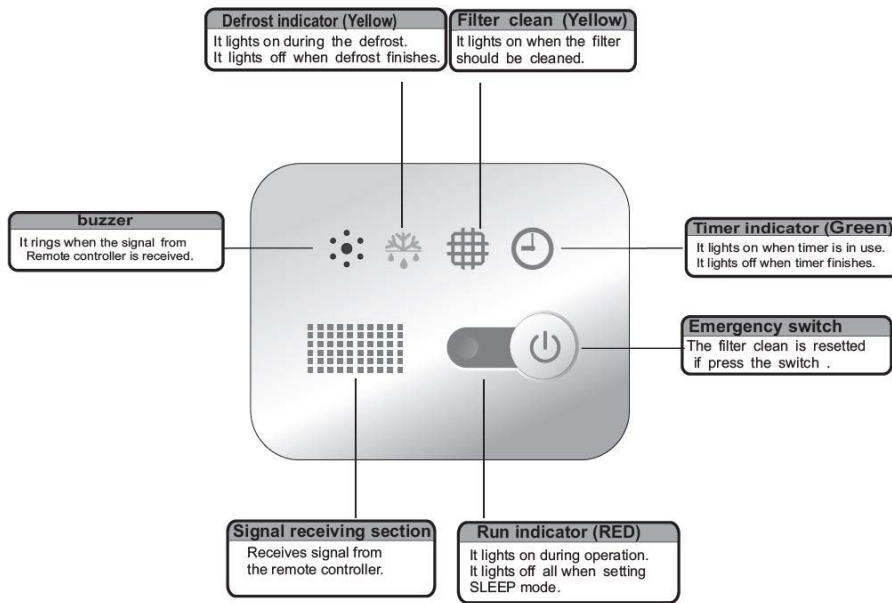

24K, 36K, 48K, 60K

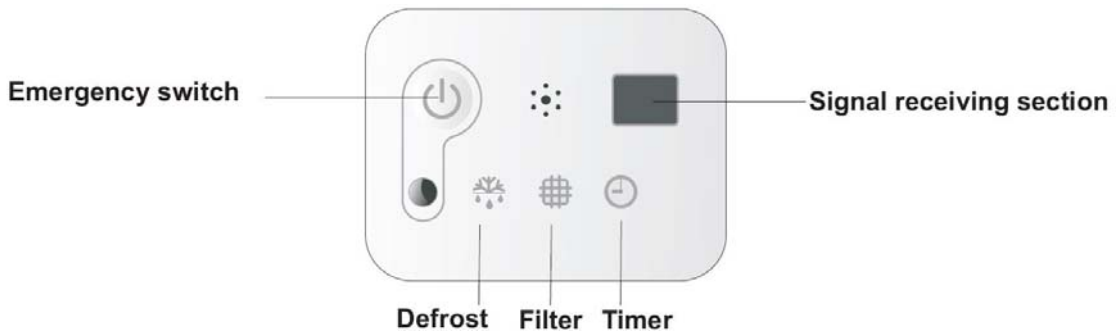

1. GENERAL

Ceiling&Floor type

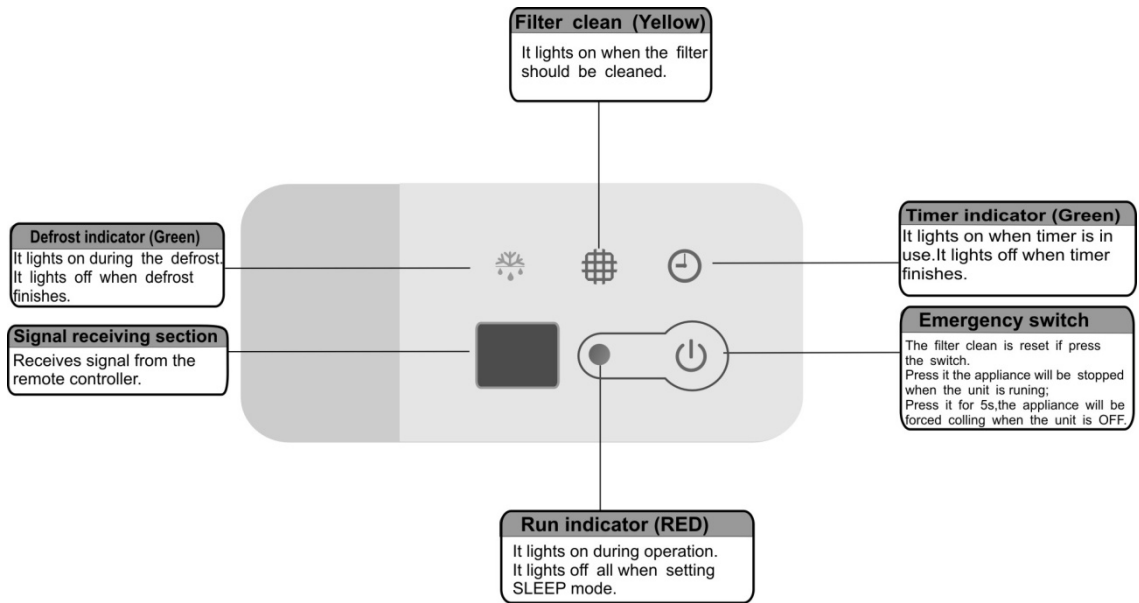

2. SPECIFICATIONS

2. Specifications

Duct Type

Model		AUD-18UX4SZKL1	AUD-24UX4SALH1	AUD-36UX4SAMH1	AUD-18UX4SGKL	AUD-24UX4SZLH	AUD-36UX4SAMH	AUD-48UX6SPHH	AUD-60UX6SPHH	
Indoor model		AUD-18UX4SKL1	AUD-24UX4SLH1	AUD-36UX4SMH1	AUD-18UX4SKL	AUD-24UX4SLH	AUD-36UX4SMH	AUD-48UX4SHH	AUD-60UX4SHH	
Outdoor model		AUW-18U4SZ1	AUW-24U4SA1	AUW-36U4SA1	AUW-18U4SG	AUW-24U4SZ	AUW-36W4SA	AUW-48U6SP	AUW-60U6SP	
Power supply		Ph-V-H z	220V-240V ~/50Hz					380V-415V , 3N~/50Hz		
Capacity	Cooling	kW	5	7	9.2	5	6.4	10	12.6	17
		Btu/h	17,000	23,900	31,400	17,000	21,800	34,100	43,000	58,000
	Heating	kW	5.6	8.1	11	5.6	7.25	11.5	15	20.5
		Btu/h	19,100	27,600	37,500	19,100	24,700	39,200	51,200	70,000
Dehumidification		L/h	1.4	1.8	2.4	1.4	1.8	2.4	3.3	4.5
Rated input	Cooling	kW	1.5	2.3	3.05	1.552	1.99	3.11	3.92	5.295
	Heating	kW	1.6	2.65	3.25	1.55	2	3.19	4.15	5.65
Rated Current	Cooling	A	6.8	10.2	13.9	6.9	8.9	13.5	7.5	10.8
	Heating	A	7.3	11.5	13.1	6.9	8.9	13.9	8	11.3
Max. input		kW	2.5	3.6	5.1	2.58	3	5.23	6.2	9.38
Max.Current		A	12	15.9	22.5	11.5	13.5	22.78	13	17.7
EER/COP			3.33/3.5	3.04/3.06	3.04/3.06	3.22/3.61	3.22/3.63	3.22/3.61	3.21/3.61	3.21/3.63
SEER/SCOP			6.11/4.01	6.11/4.01	6.11/4.01	/	/	/	/	/
Cooling Energy Class			A++	A++	A++	A	A	A	A	A
Heating Energy Class			A+	A+	A+	A	A	A	A	A
Compressor	Model		DA131S1B-28F Z	DA230S2C-31M T	DA250S2C-30MT	DA130S1C-20F Z	ATL165SD-C9A U	DA250S2C-30M T	TNB306FPNMC	LNB42FSAMC
	Type		Rotary							
	Winding resistance		Ω	0.55 (20°C)	0.73 (at20°C)	055 (20°C)	0.95 (20°C)	0.59	0.95 (20°C)	U-V:

2. SPECIFICATIONS

Model				AUD-18UX4SZKL1	AUD-24UX4SALH1	AUD-36UX4SAMH1	AUD-18UX4SGKL	AUD-24UX4SZLH	AUD-36UX4SAMH	AUD-48UX6SPHH	AUD-60UX6SPHH
Indoor model				AUD-18UX4SKL1	AUD-24UX4SLH1	AUD-36UX4SMH1	AUD-18UX4SKL	AUD-24UX4SLH	AUD-36UX4SMH	AUD-48UX4SHH	AUD-60UX4SHH
Outdoor model				AUW-18U4SZ1	AUW-24U4SA1	AUW-36U4SA1	AUW-18U4SG	AUW-24U4SZ	AUW-36W4SA	AUW-48U6SP	AUW-60U6SP
										2433;U-W :2433;	2433;U-W :2433;
										V-W: 2.304 (at 25°C)	V-W: 2.304 (at 25°C)
Brand		GMCC		GMCC	GMCC	GMCC	GMCC	HIGHLY	GMCC	mitsubishi electric	mitsubishi electric
Fan motor	Indoor	Model	YSK110-40-4-A(HS16)	SIC-70CW-F195-1	SIC-101CW-F1246-1	YSK110-40-4-A(HS16)	Y6S419C56	Y7S423C024	Y7S423C032	Y7S423C032	Y7S423C032
	Outdoor	Model	ARW4401QH	SIC-71FW-D8121-1	SIC-71FW-D8121-1	YDK29-6I-22	YDK70-6H-3	YDK95-6-9043	YDK65-6-9024 YDK65-6-9061	YDK65-6-9024 YDK65-6-9061	YDK65-6-9024 YDK65-6-9061
Fan	Indoor	type	centrifugal fan								
		Speed Hi/Med/Low	r.p.m	1130/850/950(10 Pa)	1000/910/810(30 Pa)	1060/980/900(30Pa)	1130/850/950(10 Pa)	1070/990/860(50 Pa)	1150/1070/1020(50Pa)	1250/1200/1100(120Pa)	1250/1200/1100(120Pa)
Fan speed	Outdoor	type	tube-axial								
		Speed Hi/Med/Low	r.p.m	0-810	0-810	0-810	900/750/500	840/780/560	800/640/540	700/600/500	700/600/500
Air circulation	Indoor	Hi/Med/Low	m³/h	850	1100	1800	850	1100	1700	2000	2000
	Outdoor	Hi/Med/Low	m³/h	--	--	--	--	--	--	--	--
Static Pressure(*Default Setting)			Pa	10*/30	30*/(1~80 optional)	30*/(1~80 optional))	10*/30	50*/80	50*/80	80*/120	80*/120
Operating control			Wireless Remote control-J1-05(E)								
Dimensions	Indoor	L×W×H	mm	1170×447×190	900×720×270	1300×720×270	1170×447×190	900×720×270	1300×720×270	1300×800×350	1300×800×350
	Outdoor	L×W×H	mm	900×300×640	950×340×840	950×340×840	800×260×570	900×300×640	940×340×840	950×340×1386	950×340×1386
Packing	Indoor	L×W×H	mm	1340×580×236	1170X340X870	1570X340X870	1340×580×236	1170X340X870	1570X340X870	1550X940X410	1550X940X410
	Outdoor	L×W×H	mm	1050×400×700	1110×460×980	1110×460×980	950×365×645	1050×700×400	1110×460×980	1110×460×1530	1110×460×1530
Weight	Indoor	Net/Gross	kg	24/28	32/37	43/51	24/28	32/37	38/43	50/58	50/58

2. SPECIFICATIONS

Model				AUD-18UX4SZKL1	AUD-24UX4SALH1	AUD-36UX4SAMH1	AUD-18UX4SGKL	AUD-24UX4SZLH	AUD-36UX4SAMH	AUD-48UX6SPHH	AUD-60UX6SPHH
Indoor model				AUD-18UX4SKL1	AUD-24UX4SLH1	AUD-36UX4SMH1	AUD-18UX4SKL	AUD-24UX4SLH	AUD-36UX4SMH	AUD-48UX4SHH	AUD-60UX4SHH
Outdoor model				AUW-18U4SZ1	AUW-24U4SA1	AUW-36U4SA1	AUW-18U4SG	AUW-24U4SZ	AUW-36W4SA	AUW-48U6SP	AUW-60U6SP
	Outdoor	Net/Gross	kg	45/51	69/73	70/74	35.5/39	50/56	70/74	101/107	108/112
Noise lever	Indoor	Hi/Med/Low	dB(A)	--/54(SOUND POWER)	--/61(SOUND POWER)	--/56(SOUND POWER)	--/41	43/49	43/51	49/53	49/53
	Outdoor	Hi/Med/Low	dB(A)	--/62(SOUND POWER)	--/66(SOUND POWER)	--/70(SOUND POWER)	--/56	53/58	--/58	--/60	--/60
Refrigerant piping	Gas/Liquid		mm	12.7/6.35	15.88/9.52	15.88/9.52	12.7/6.35	15.88/9.52	15.88/9.52	19.05/9.52	19.05/9.52
	Max. refrigerant pipe length		m	20	30	30	20	30	30	50	50
	Max. difference in level		m	10	20	20	10	15	15	30	30
	Connection method			Flare							
Connection	Power wiring	mm ²	3 core x1.5	3 core x2.5	3 core x2.5	3 core x1.5	3 core x2.5	3 core x2.5	3 core x2.5	5 core x2.5	5 core x2.5
wiring	Signal wiring	mm ²	4core x0.75	4core x0.75	4core x0.75	4core x0.75	4core x0.75	4core x0.75	4core x0.75	4core x0.75	4core x0.75
Refrigerant charge(R410a)			kg	1.4	1.68	2.1	1.27	1.5	2.1	3	3.5
Throttle Type				EEV	EEV	EEV	EEV	EEV	EEV	EEV	EEV
Ambient temp			°C	Cooling -15 ~ 48			Cooling 15 ~ 43			Cooling -15 ~ 48	
				Heating -10 ~ 24			Heating -10 ~ 24			Heating -10 ~ 24	

2. SPECIFICATIONS

Cassette type

Model		AUC-18UR4SZAA1	AUC-24UR4SAEA1	AUC-36UR4SAEA1	AUC-18UX4SGAA	AUC-24UX4SZEAA	AUC-36UX4SAEA1	AUC-48UX6SPFA	AUC-60UX6SPFA	
Indoor model		AUC-18UR4SAA1	AUC-24UR4SEA1	AUC-36UR4SEA1	AUC-18UX4SAA	AUC-24UX4SEA	AUC-36UX4SEA	AUC-48UX4SFA	AUC-60UX4SFA	
Outdoor model		AUW-18U4SZ1	AUW-24U4SA1	AUW-36U4SA1	AUW-18U4SG	AUW-24U4SZ	AUW-36W4SA	AUW-48U6SP	AUW-60U6SP	
Power supply		Ph-V-Hz	20V-240V ~/50Hz					380V-415V , 3N~/50Hz		
Capacity	Cooling	kW	5 (1.2-6.5)	7.0 (2.2-8.0)	9.5 (3.6 ~ 10.5)	5	6.4	10	12	17
		Btu/h	17,100(4,100-22,200)	23,900 (7,500-27,300)	32,400 (12,300-35,800)	17000	21800	34100	41000	58000
	Heating	kW	5.6(1.8-7.2)	8.2 (2.5-10)	11.0(3.05 ~ 13.8)	5.6	7	11.5	15	20
		Btu/h	19,100(6,100-24,600)	28,000 (8,500-34,100)	37,500 (10,400-47,100)	19100	23900	39200	51200	68200
Dehumidification		L/h	—	—	—	—	—	—	—	
Rated input	Cooling	kW	1.49 (0.40 ~ 2.25)	2.3 (0.40 ~ 3.6)	3.07(0.4 ~ 4.2)	1.552	1.91	3.07	3.72	5.095
	Heating	kW	1.75(0.38 ~ 2.15)	2.73(0.38 ~ 3.6)	3.10(0.38 ~ 4.2)	1.55	1.92	3.15	3.95	5.45
Rated Current	Cooling	A	6.6	10.1	13.4	6.9	8.5	13.36	6.5	9.8
	Heating	A	7.8	12.2	13.5	6.89	8.5	13.76	7	10.3
Max. input	Cooling	kW	2.5	3.6	4.25	2.421	2.92	4.55	5.32	8.5
	Heating	kW	2.5	3.6	4.25	2.581	2.72	4.85	5.92	9.1
Max.Current	Cooling	A	12	15.5	20	9.9	13.1	19.83	10.7	10.7
	Heating	A	12	15.5	20	11.47	12.1	21.13	11.7	11.7
EER/COP			3.36/3.20	3.04/3.0	3.09/3.55	3.22/3.61	3.35/3.64	3.26/3.65	3.39/3.8	3.34/3.67
SEER/SCOP			6.11/4.01	6.11/4.01	6.11/4.01	/	/	/	/	/
Cooling Energy Class			A++	A++	A++	A	A	A	A	A
Heating Energy Class			A+	A+	A+	A	A	A	A	A

2. SPECIFICATIONS

Model				AUC-18UR4SZAA1	AUC-24UR4SAEA1	AUC-36UR4SAEA1	AUC-18UX4SGAA	AUC-24UX4SZEAA	AUC-36UX4SAEA1	AUC-48UX6SPFA	AUC-60UX6SPFA
Indoor model				AUC-18UR4SAA1	AUC-24UR4SEA1	AUC-36UR4SEA1	AUC-18UX4SAA	AUC-24UX4SEA	AUC-36UX4SEA	AUC-48UX4SFA	AUC-60UX4SFA
Outdoor model				AUW-18U4SZ1	AUW-24U4SA1	AUW-36U4SA1	AUW-18U4SG	AUW-24U4SZ	AUW-36W4SA	AUW-48U6SP	AUW-60U6SP
Compressor	Model			DA131S1B-28F Z	DA230S2C-31M T	DA250S2C-30M T	DA130S1C-20F Z	ATL165SD-C9A U	DA250S2C-30MT	TNB306FPNMC	LNB42FSAMC
	Type			Rotary							
	Winding resistance		Ω	0.55 (20°C)	0.73 (at20°C)	0.55 (20°C)	0.95 (20°C)	0.59	0.95 (20°C)	U-V: 2433;U-W :2433;	U-V: 2433;U-W :2433;
										V-W: 2.304 (at 25°C)	V-W: 2.304 (at 25°C)
Brand			GMCC	GMCC	GMCC	GMCC	HIGHLY	GMCC	MITSUBISHI ELECTRIC	MITSUBISHI ELECTRIC	
Fan motor	Indoor		Mode I	EHDS50AQ	ARW5901QH	EHDS50AQH	YDK95-28-4-B	ARW5901QH	EHDS50AQH	SIC72FW-D8124-2B	SIC72FW-D8124-2B
	Outdoor		Mode I	ARW4401QH	SIC-71FW-D812 1-1	SIC-71FW-D812 1-1	YDK29-6I-22	YDK70-6H-3	YDK95-6-9043	YDK65-6-9024 YDK65-6-9061	YDK65-6-9024 YDK65-6-9061
Fan	Indoor	type		centrifugal fan							
		Speed Hi/Med/Low	r.p.m	980/840/720	440/380/370	630/520/460	980/840/720	440/370/280	630/520/460	630/520/460	630/520/460
Fan speed	Outdoor	type		tube-axial							
		Speed Hi/Med/Low	r.p.m	0-810	0-810	0-810	900/750/500	840/780/560	800/640/540	700/600/500	700/600/500
Air circulation	Indoor	Hi/Med/Low	m ³ /h	850	1100	1600	850	1100	1600	2000	2400
	Outdoor	Hi/Med/Low	m ³ /h	--	--	--	--	--	--	--	--
Static Pressure(*Default Setting)			Pa	0	0	0	0	0	0	0	0
Operating control				Wireless Remote control (J1-05)							
Dimensions	Indoor	L×W×H	mm	650×570×270	840×840×248	840×840×248	650×570×270	840×840×248	840×840×248	840×840×298	840×840×298
	Outdoor	L×W×H	mm	900×300×640	950×340×840	950×340×840	800×260×570	900×300×640	940×340×840	950×340×1386	950×340×1386

2. SPECIFICATIONS

Model				AUC-18UR4SZAA1	AUC-24UR4SAEA1	AUC-36UR4SAEA1	AUC-18UX4SGAA	AUC-24UX4SZEAA	AUC-36UX4SAEA	AUC-48UX6SPFA	AUC-60UX6SPFA
Indoor model				AUC-18UR4SAA1	AUC-24UR4SEA1	AUC-36UR4SEA1	AUC-18UX4SAA	AUC-24UX4SEA	AUC-36UX4SEA	AUC-48UX4SFA	AUC-60UX4SFA
Outdoor model				AUW-18U4SZ1	AUW-24U4SA1	AUW-36U4SA1	AUW-18U4SG	AUW-24U4SZ	AUW-36W4SA	AUW-48U6SP	AUW-60U6SP
	Panel	L×W×H	mm	650×650×30	950×950×37	950×950×37	650×650×30	950×950×37	950×950×37	950×950×37	950×950×37
Packing	Indoor	L×W×H	mm	770×750×310	930×930×290	930×930×290	770×750×310	930×930×290	930×930×290	930×930×340	930×930×340
	Outdoor	L×W×H	mm	1050×400×700	1110×460×980	1110×460×980	940×360×640	1050×700×400	1110×460×980	1110×460×1530	1110×460×1530
	Panel	L×W×H	mm	730×730×130	1010×990×95	1010×990×115	730×730×130	1010×990×95	1010×990×95	1010×990×95	1010×990×95
Weight	Indoor	Net/Gross	kg	21/25.5	24/30	26/32	21/25.5	24/30	26/32	29/35	29/35
	Outdoor	Net/Gross	kg	45/51	69/73	70/74	35.5/39	50/56	70/74	101/107	108/112
	Panel	Net/Gross	kg	2.4/5	6/7.5	6/7.5	2.4/5	6/7.5	6/7.5	6/7.5	6/7.5
Noise lever	Indoor	Low/Hi/sound power	Db	--/48/58	36/42/53	--/50/61	--/48	36/42	--/50	43/49	43/49
	Outdoor	Low/Hi/sound power	Db	45/50/62	--/--/66	--/58/70	--/56	53/58	--/58	--/60	--/60
Refrigerant piping	Gas/Liquid		mm	12.7/6.35	15.88/9.52	15.88/9.52	12.7/6.35	15.88/9.52	15.88/9.52	19.05/9.52	19.05/9.52
	Max. refrigerant pipe length		m	20	30	30	20	30	30	50	50
	Max. difference in level		m	10	20	20	10	15	15	30	30
	Connection method			Flare							
Connection	Power wiring	mm ²	3 core x1.5	3 core x2.5	3 core x2.5	3 core x1.5	3 core x2.5	3 core x2.5	3 core x2.5	5 core x2.5	5 core x2.5
wiring	Signal wiring	mm ²	4 core shielded wire x 0.75				4core x0.75	4core x0.75	4core x0.75	4core x0.75	4core x0.75
Refrigerant charge(R410a)			kg	1.4	1.68	2.1	1.27	1.5	2.1	3	3.5
Throttle Type				EEV	EEV	EEV	EEV	EEV	EEV	EEV	EEV
Ambient temp			°C	Cooling -15 ~ 48			Cooling 15 ~ 43			Cooling -15 ~ 48	
				Heating -10 ~ 24			Heating -10 ~ 24			Heating -10 ~ 24	

2. SPECIFICATIONS

Ceiling & Floor type

Model			AUV-18UR4SZA1	AUV-24UR4SAA1	AUV-36UR4SAB1	AUV-48UR6SPC	AUV-60UR6SPC
Power supply		Ph-V-Hz	1N,220V-240V/50Hz			3N~,380V-415V/50Hz	
Capacity	Cooling	kW	5.0	7.0	9.2	12.6	17.0
		Btu/h	17,000	23,900	31,400	43,000	58,000
	Heating	kW	5.8	8.6	11.0	15.3	20.5
		Btu/h	19,800	29,000	37,500	52,200	70,000
Dehumidification		L/h	1.4	1.8	2.4	3.3	4.5
Rated input	Cooling	kW	1.55	2.3	3.05	3.92	5.295
	Heating	kW	1.75	2.77	3.3	4.2	5.65
Rated Current	Cooling	A	7.0	10.1	13.9	7.5	10.8
	Heating	A	8.0	13.0	15.0	8.0	11.3
Max. input		kW	2.5	3.6	5.1	6.2	9.38
Max.Current		A	12.0	15.9	22.5	13.0	17.7
EER/COP			3.23/3.31	3.04/3.10	3.02/3.33	3.21/3.64	3.21/3.61
SEER/SCOP			6.11/4.01	6.11/4.01	6.11/4.01	/	/
Cooling Energy Class			A++	A++	A++	A	A
Heating Energy Class			A+	A+	A+	A	A
Compressor	Model		DA131S1B-28FZ	DA230S2C-31MT	DA250S2C-30MT	TNB306FPNMC	LNB42FSAMC
	Type		Rotary				
	Winding resistance	Ω	M:2.1 , A:2.81	M:1.37 , A:1.7	U-V: 2.806;U-W :2.806;	U-V: 2433;U-W :2433;	U-V: 2433;U-W :2433;
					V-W: 2.651 (at 25°C)	V-W: 2.304 (at 25°C)	V-W: 2.304 (at 25°C)
Brand		GMCC	GMCC	GMCC	mitsubishi electric	MITSUBISHI ELECTRIC	
Fan motor	Indoor	Model	YSK110-22-4-A(HS24)	SIC-70CW-F1100-6	SIC-70CW-F1140-3	Y7S423C032	Y7S423C032

2. SPECIFICATIONS

Model				AUV-18UR4SZA1	AUV-24UR4SAA1	AUV-36UR4SAB1	AUV-48UR6SPC	AUV-60UR6SPC
	Outdoor	Winding resistance (at20°C)		M:187A:245,60,33,143	M:209.4;A:245,60,33,143	M:75;A:97.5	M:79.7;A:59.4,20.2,108	M:79.7;A:59.4,20.2,108
		Model		ARW4401QH	SIC-71FW-D8121-1	SIC-71FW-D8121-1	YDK65-6-9024	YDK65-6-9024
		Winding resistance (at20°C)		M:231.5;A:168	M:78;A:36.2,51.5,109.2	M:59.1;A:85.8	M:83;A1:23.4A2:14A1:6 3.5	M:83;A1:23.4A2:14A1:6 63.5
Fan	Indoor	type		centrifugal fan				
		Speed Hi/Med/Low	r.p.m	630/720/850	910/1030/1150	1080/1160/1220	1000/1100/1200	1000/1100/1200
Fan speed	Outdoor	type		tube-axial				
		Speed Hi/Med/Low	r.p.m	0-810	0-810	0-810	500/600/700	500/600/700
Air circulation	Indoor	Hi/Med/Low	m³/h	800	1100	1600	2000	2000
	Outdoor	Hi/Med/Low	m³/h	--	--	--	--	--
Static Pressure(*Default Setting)			Pa	0	0	0	0	0
Operating control				Wireless Remote control-J1-05(E)				
Dimensions	Indoor	L×W×H	mm	990×680×230	990×680×230	1290×680×230	1580×680×230	1580×680×230
	Outdoor	L×W×H	mm	900×300×640	950×340×840	950×340×840	950×340×1386	950×340×1386
Packing	Indoor	L×W×H	mm	1100×820×350	1100×820×350	1400×820×350	1690×820×350	1690×820×350
	Outdoor	L×W×H	mm	1050×700×400	1110×460×980	1110×460×980	1110×460×1530	1110×460×1530
Weight	Indoor	Net/Gross	kg	27/33	30/35	37/44	47/54	47/54
	Outdoor	Net/Gross	kg	45/51	69/73	70/74	101/107	108/112
Noise lever	Indoor	Hi/Med/Low	dB(A)	--/54(SOUND POWER)	--/63(SOUND POWER)	--/64(SOUND POWER)	48/50/53	48/50/53
	Outdoor	Hi/Med/Low	dB(A)	--/62(SOUND POWER)	--/66(SOUND POWER)	--/70(SOUND POWER)	--/60	--/60

2. SPECIFICATIONS

Model			AUV-18UR4SZA1	AUV-24UR4SAA1	AUV-36UR4SAB1	AUV-48UR6SPC	AUV-60UR6SPC	
					POWER)			
Refrigerant piping	Gas/Liquid	mm	12.7/6.35	15.88/9.52	15.88/9.52	19.05/9.52	19.05/9.52	
	Max. refrigerant pipe length	m	15	30	30	50	50	
	Max. difference in level	m	7.5	15	15	20 (outdoor blow : 15)	20 (outdoor blow : 15)	
	Connection method		Flare					
Connection	Power wiring	mm ²	3 core x1.5	3 core x2.5	3 core x2.5	5 core x2.5	5 core x2.5	
wiring	Signal wiring	mm ²	4core x0.75	4core x0.75	4core x0.75	4core x0.75	4core x0.75	
Refrigerant charge(R410a)		kg	1.4	1.68	2.1	3	3.5	
Throttle Type			EEV	EEV	EEV	EEV	EEV	
Ambient temp		°C	Cooling -15 ~ 48					
			Heating -10 ~ 24					

3. OUTLINES AND DIMENSION

3. OUTLINES AND DIMENSIONS

3-1 INDOOR

Duct type

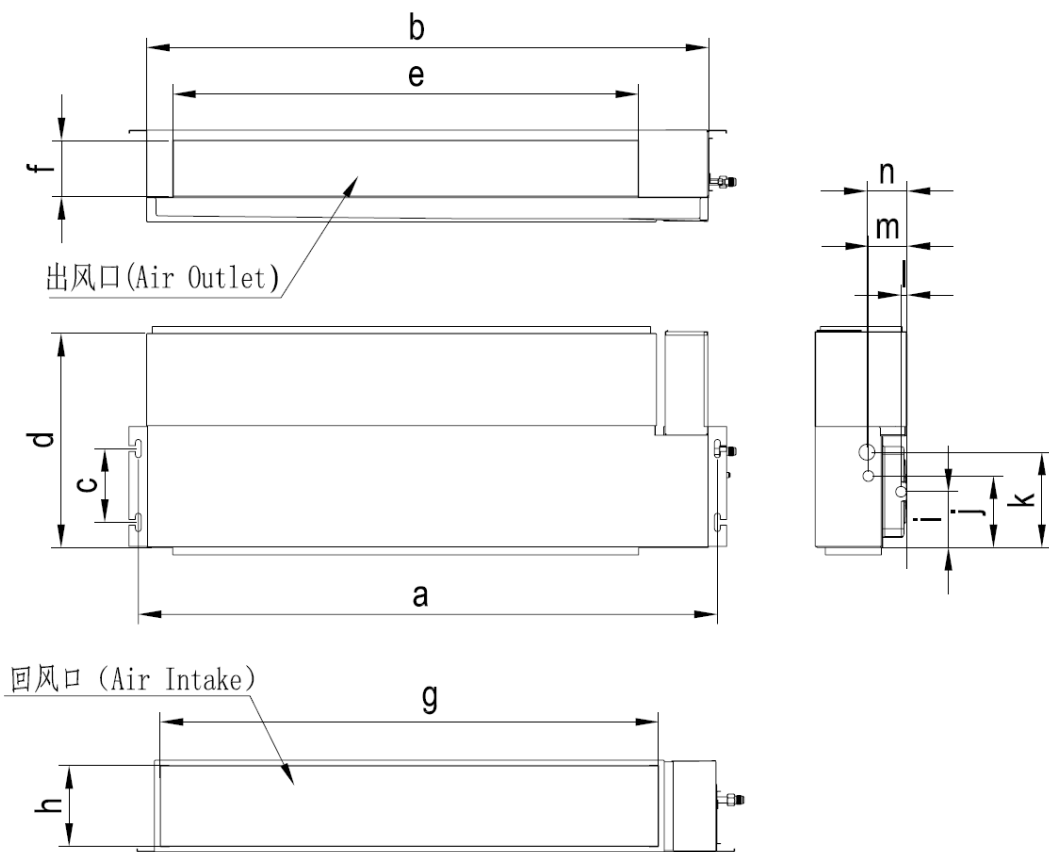

	a	b	c	d	e	f	g	h	i	j	k	l	m	n
18K	1207	1170	154	447	971	117	1039	170	117	150	199	13	81	84

3. OUTLINES AND DIMENSION

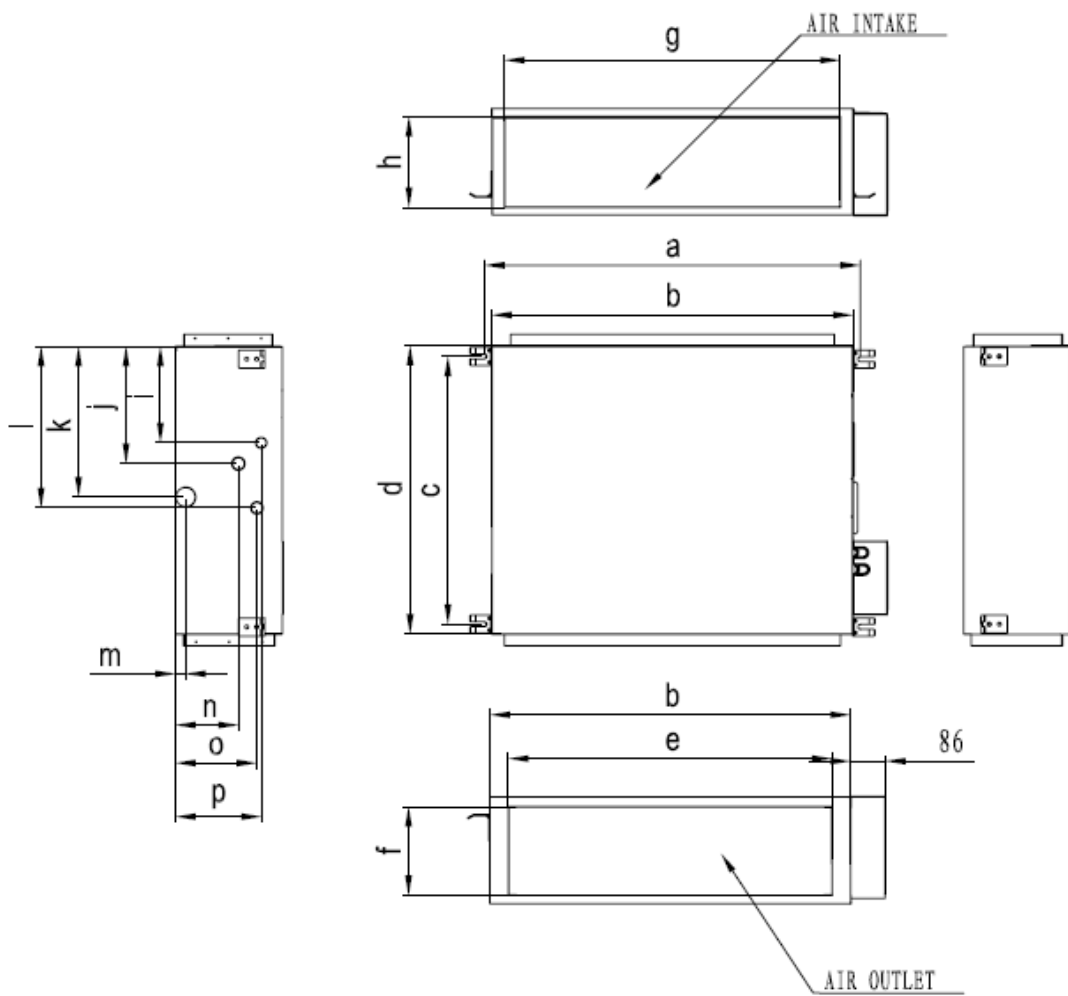

	a	b	c	d	e	f	g	h	i	j	k	l	m	n	o	p	q
24k	934	900	669	720	805	222	835	228	242	294	378	405	25	156	202	214	270
36K																	
/48k	1334	1295	740	796	1205	222	1235	308	237	312	375	405	25	204	203	242	350
/60k																	

3. OUTLINES AND DIMENSION

Cassette Type

18k

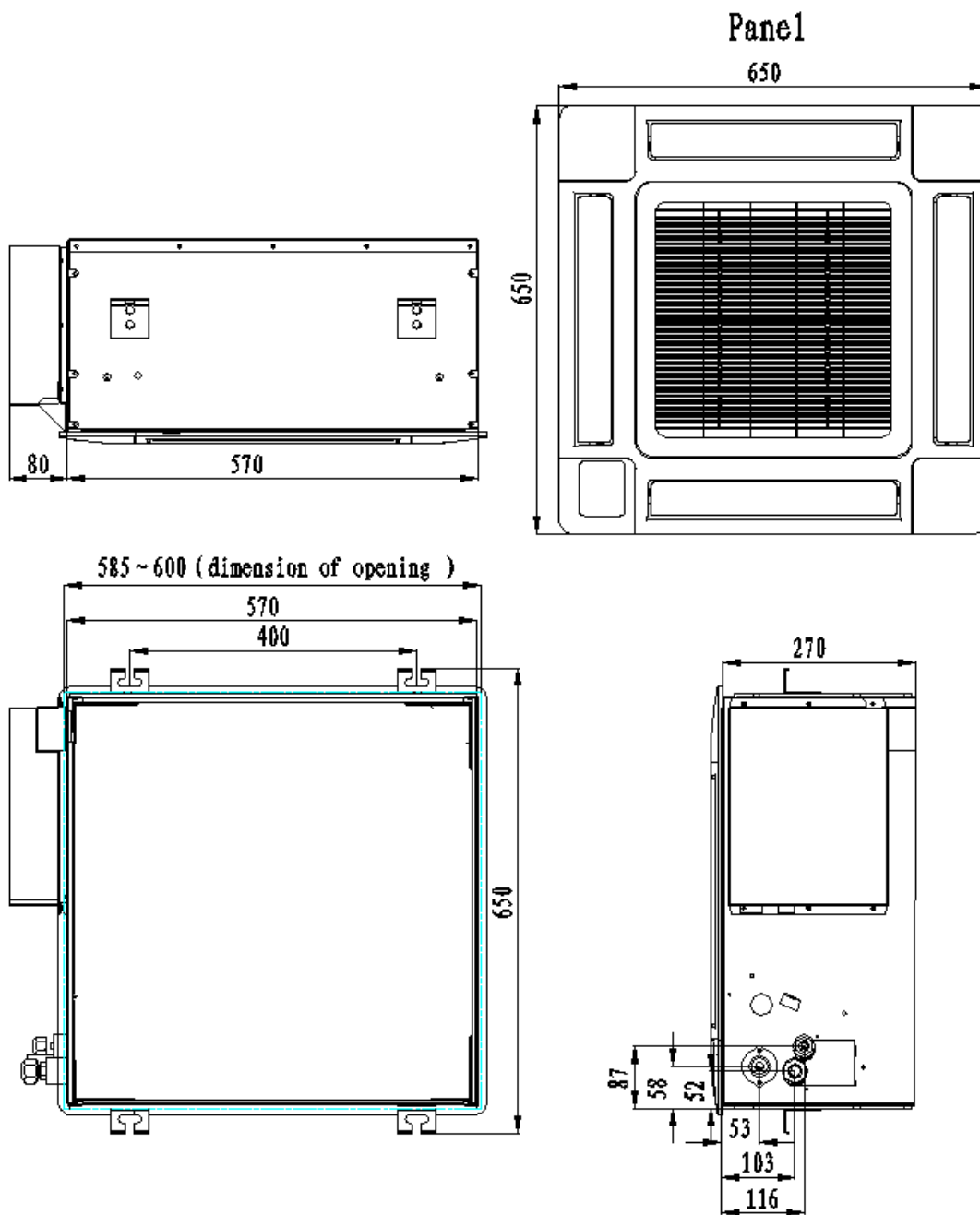

3. OUTLINES AND DIMENSION

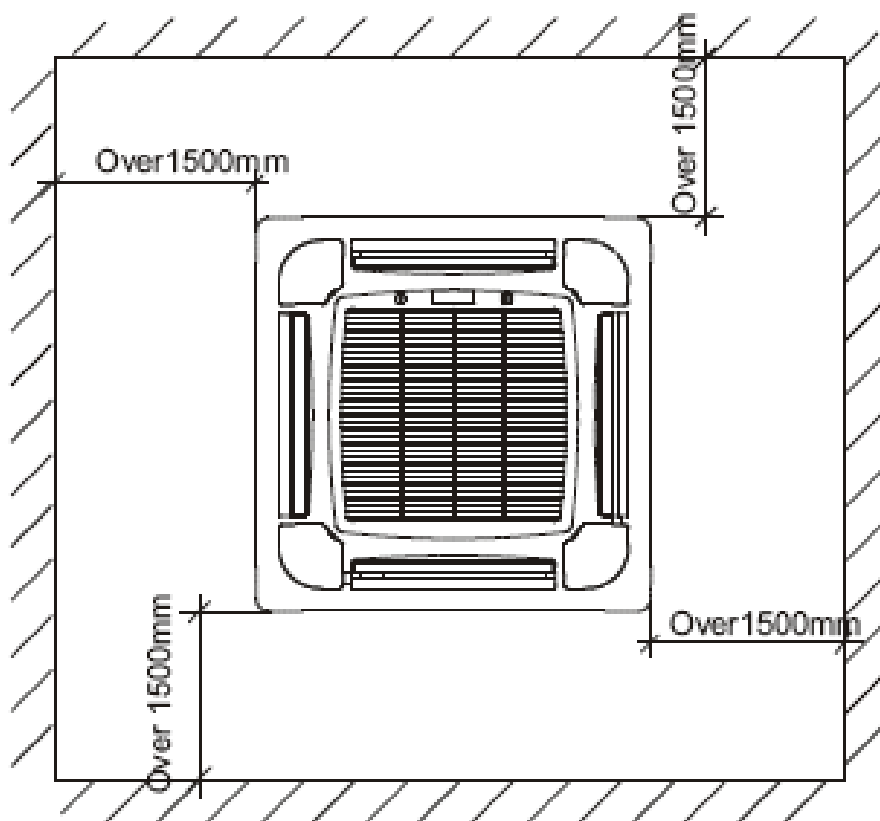
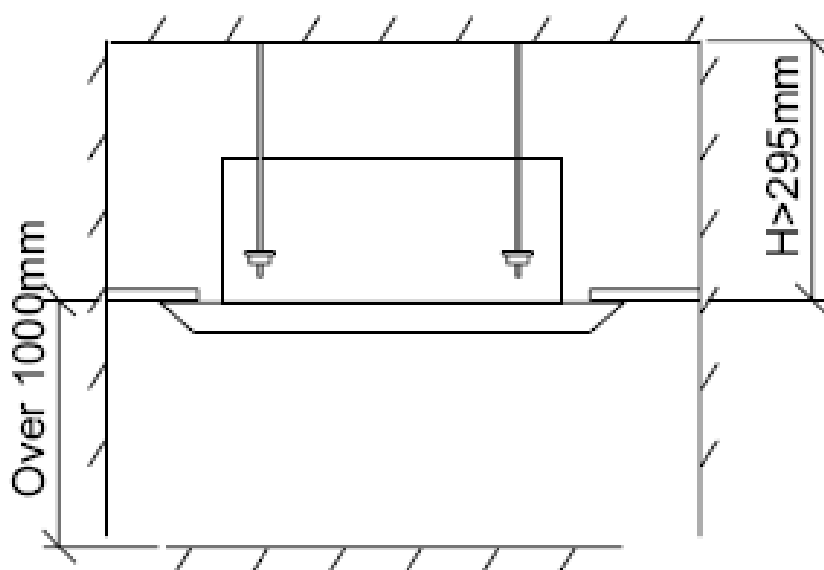

3. OUTLINES AND DIMENSION

24K,36K,48K,60K

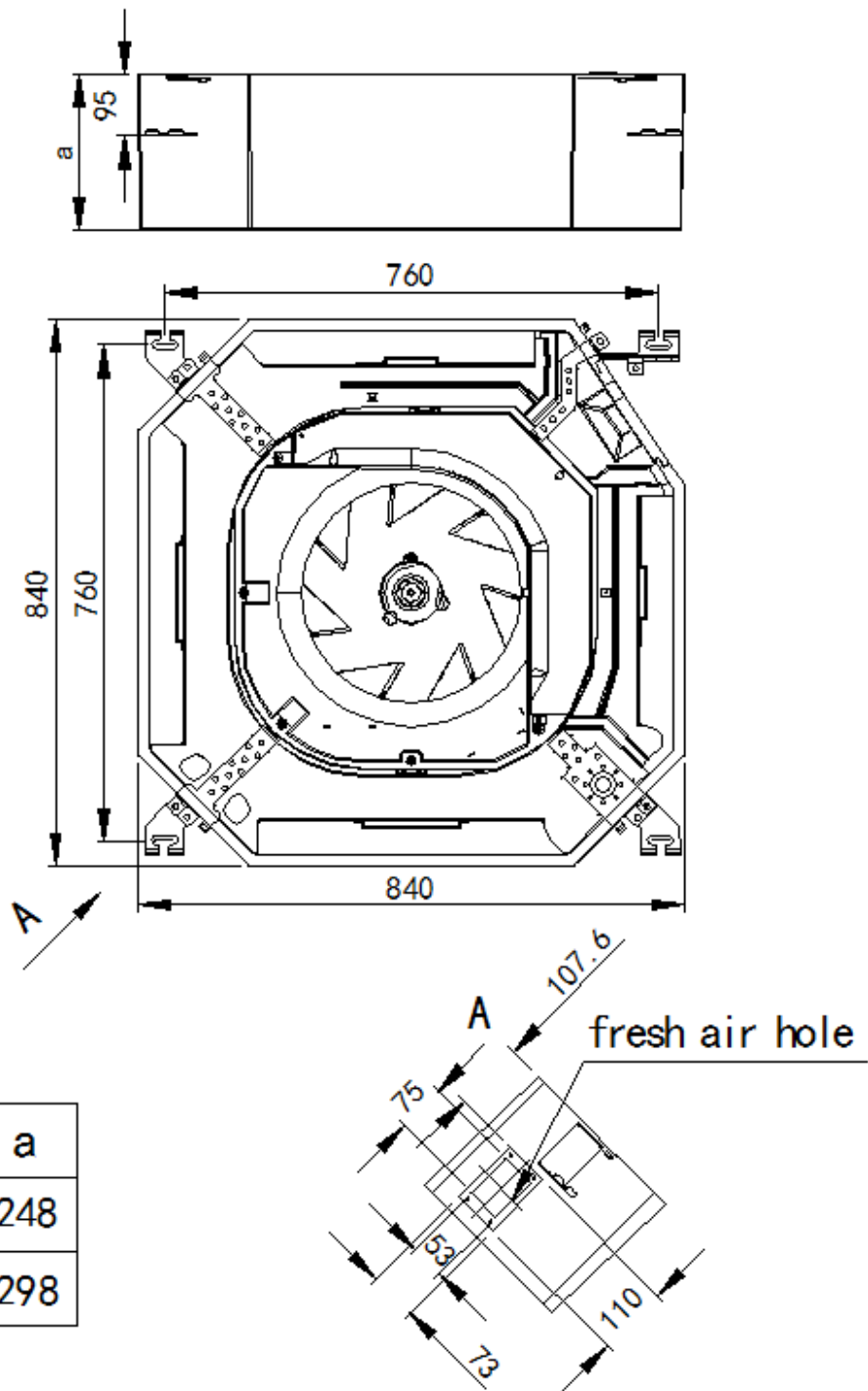

3. OUTLINES AND DIMENSION

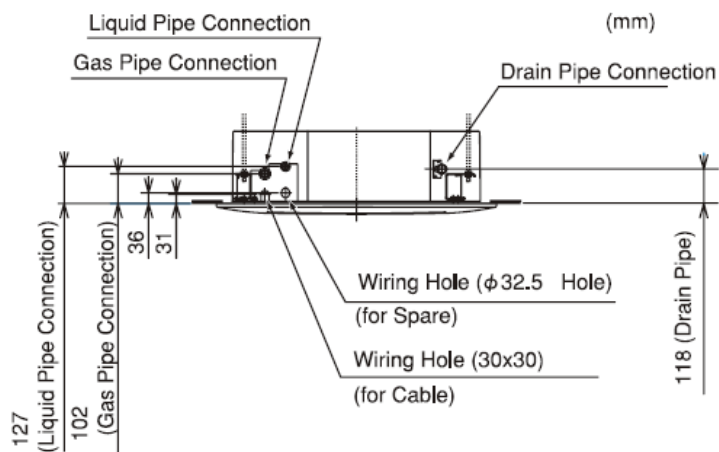
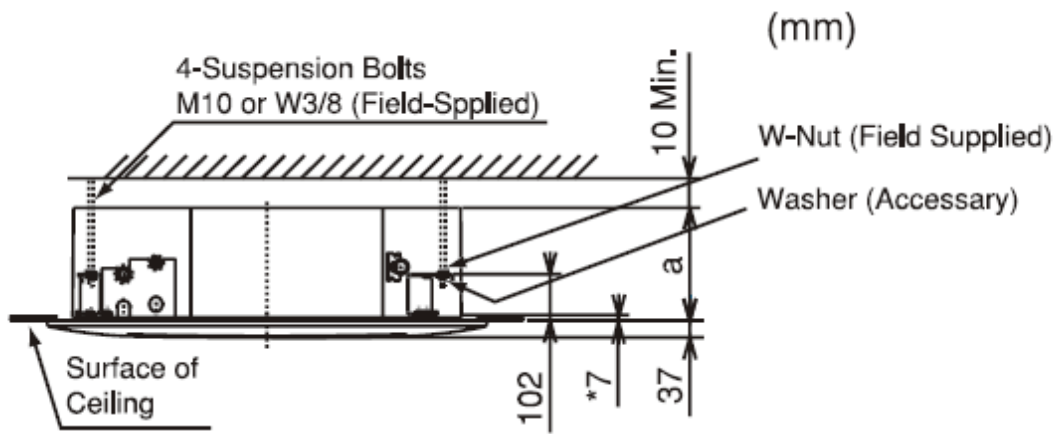
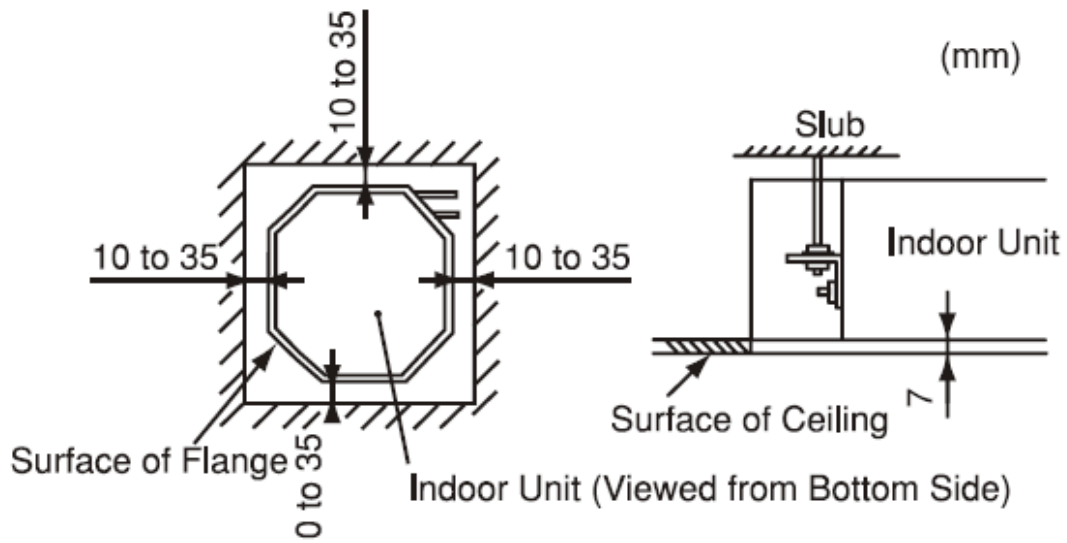

3. OUTLINES AND DIMENSION

Ceiling&Floor Type

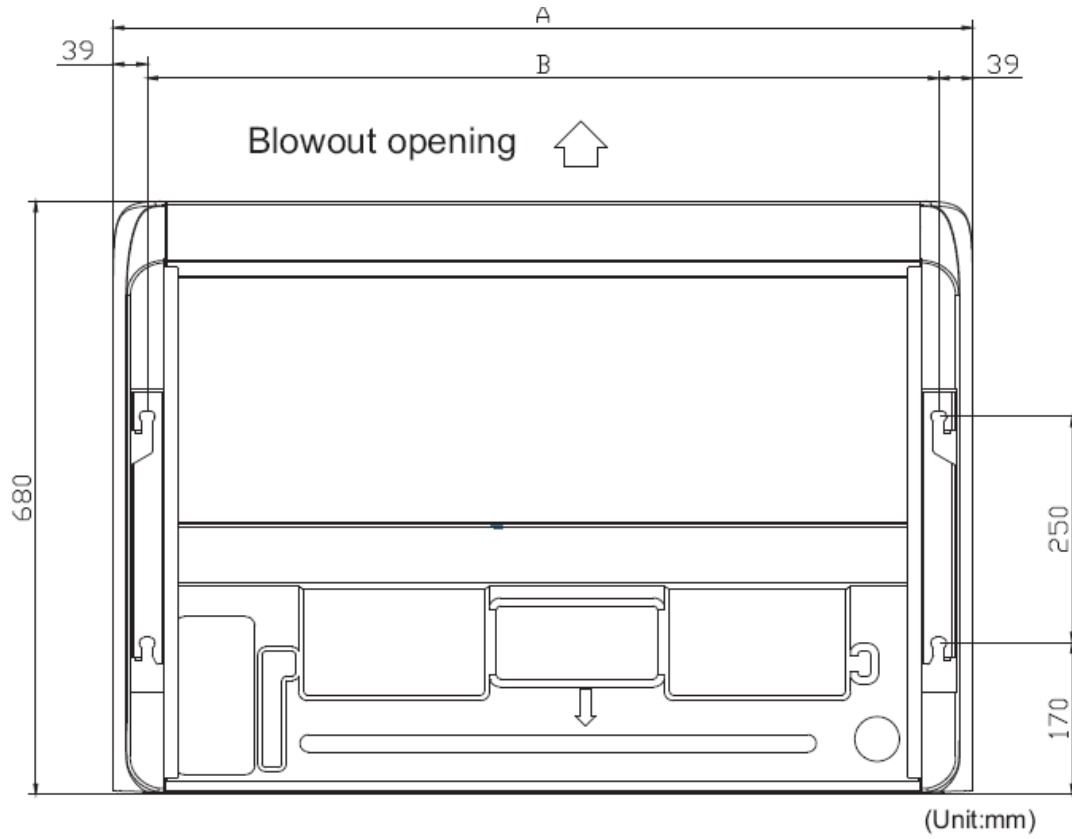

Capacity(Btu/h)	A	B
18K, 24K	990	912
36K	1285	1207
48K, 60K	1580	1502

3. OUTLINES AND DIMENSION

3-2.OUTDOOR

18K(AUW-18U4SG)

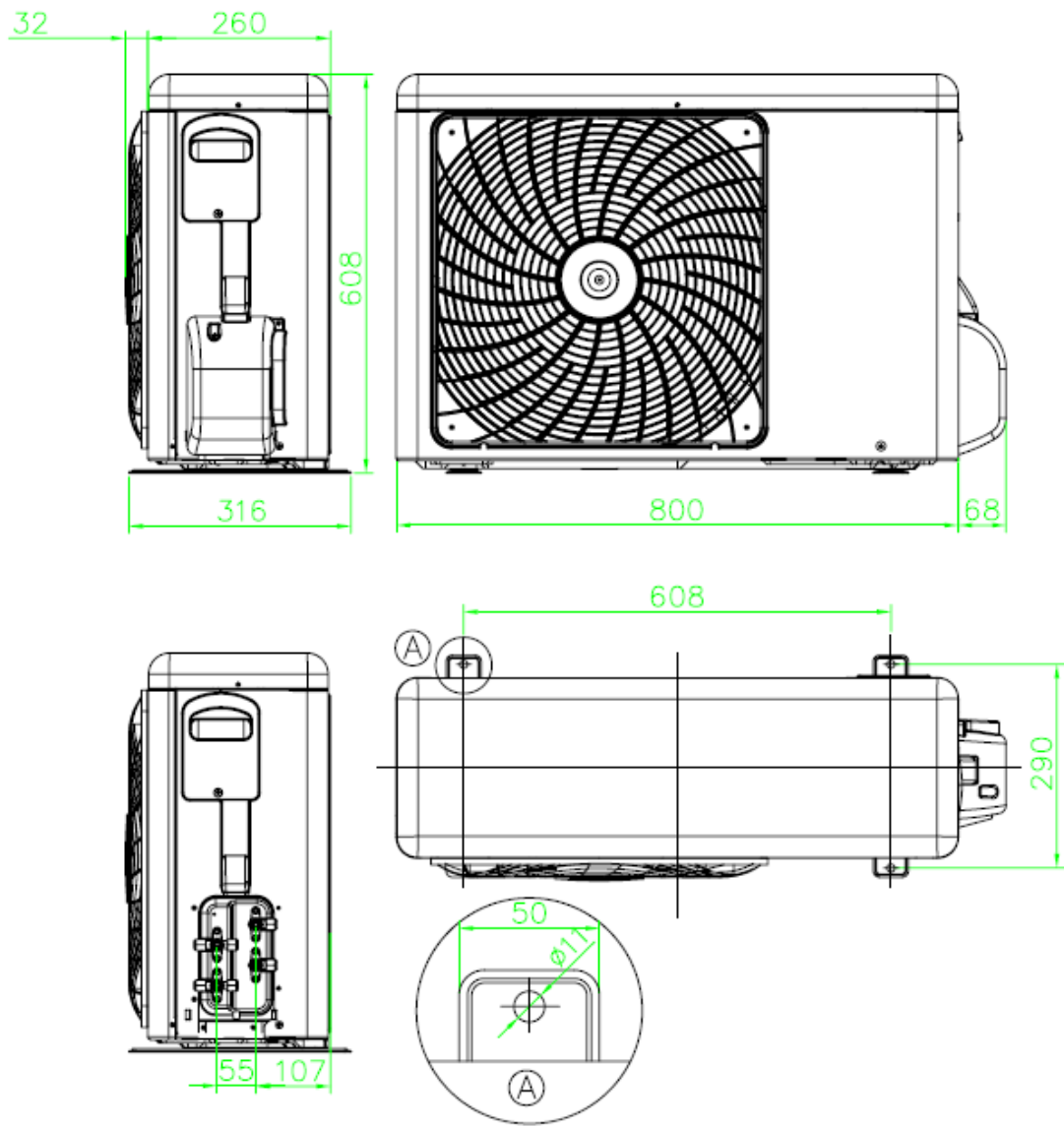

3. OUTLINES AND DIMENSION

18K (MODEL: AUW-18U4SZ1)

24K(MODEL: AUW-24U4SZ)

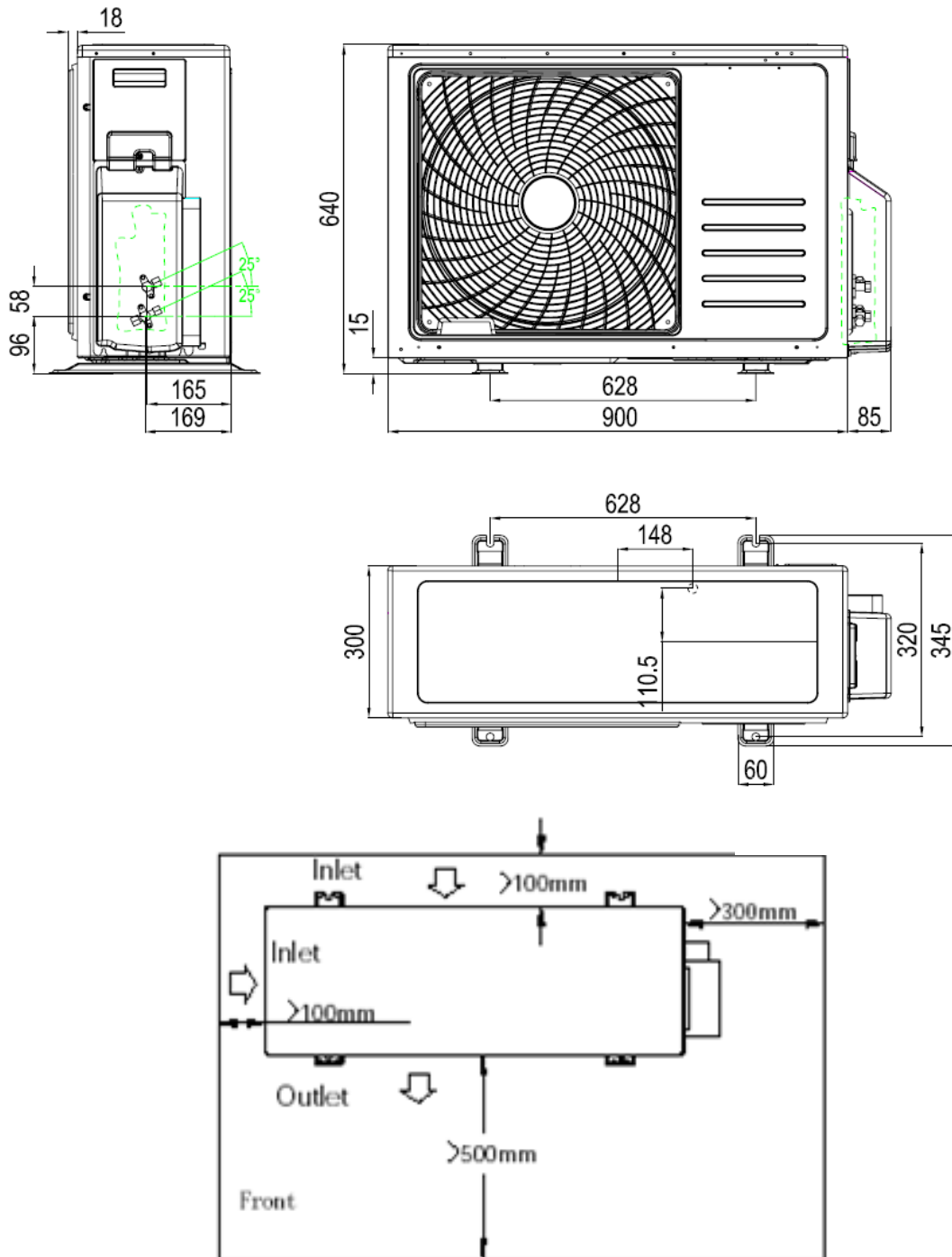

3. OUTLINES AND DIMENSION

24&36K

(MODEL: AUW-24U4SA1, AUW-36U4SA1, AUW-36W4SA)

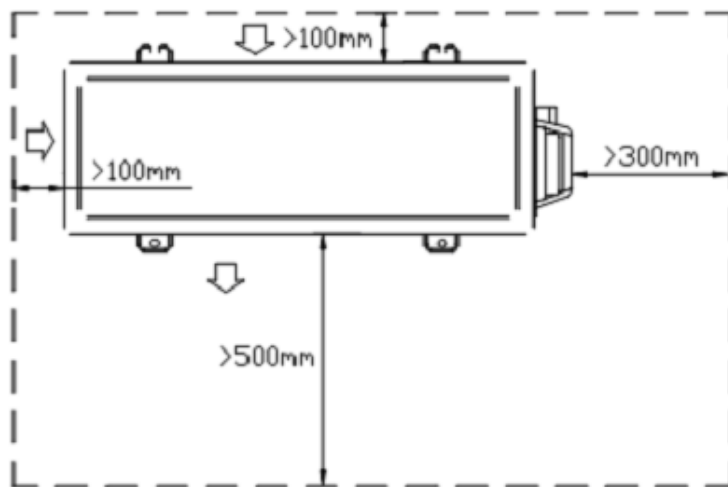
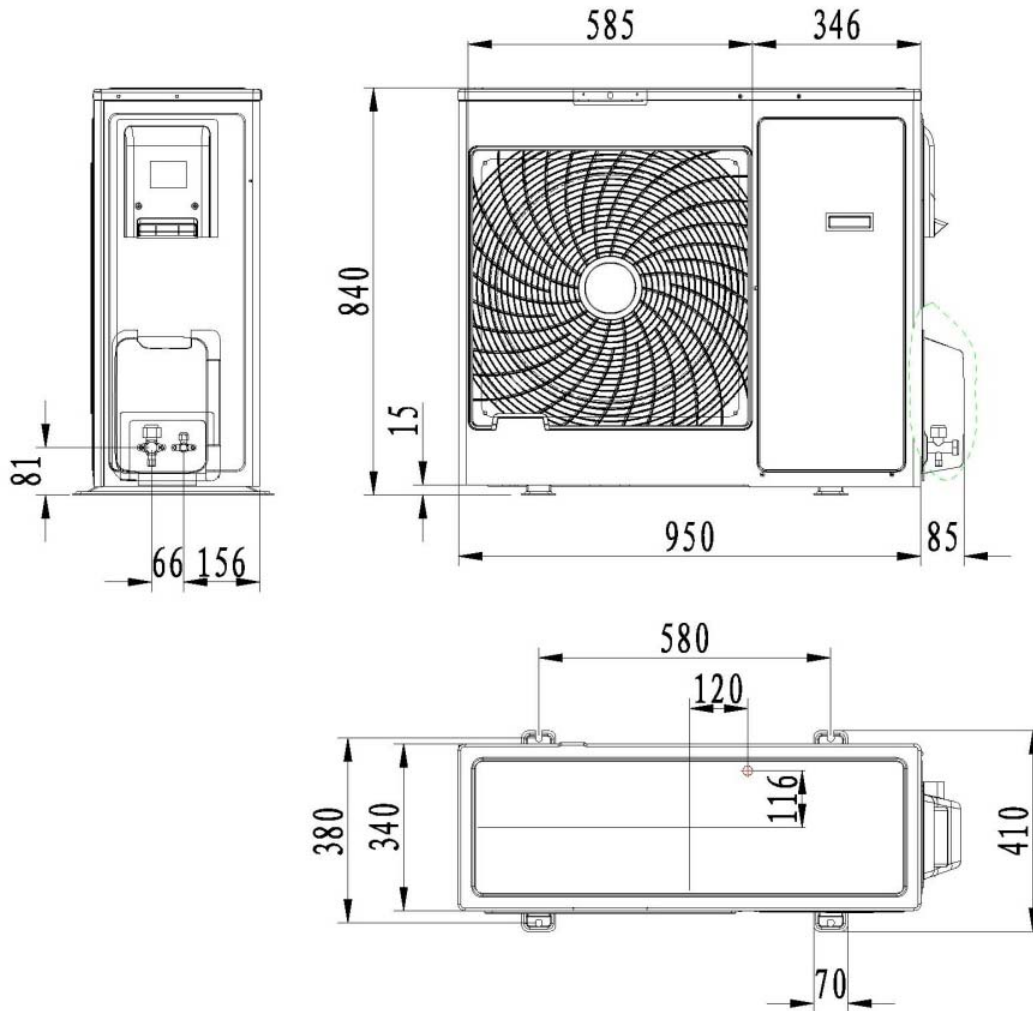

3. OUTLINES AND DIMENSION

48K&60K
(MODEL: AUW-48U6SP、AUW-60U6SP)

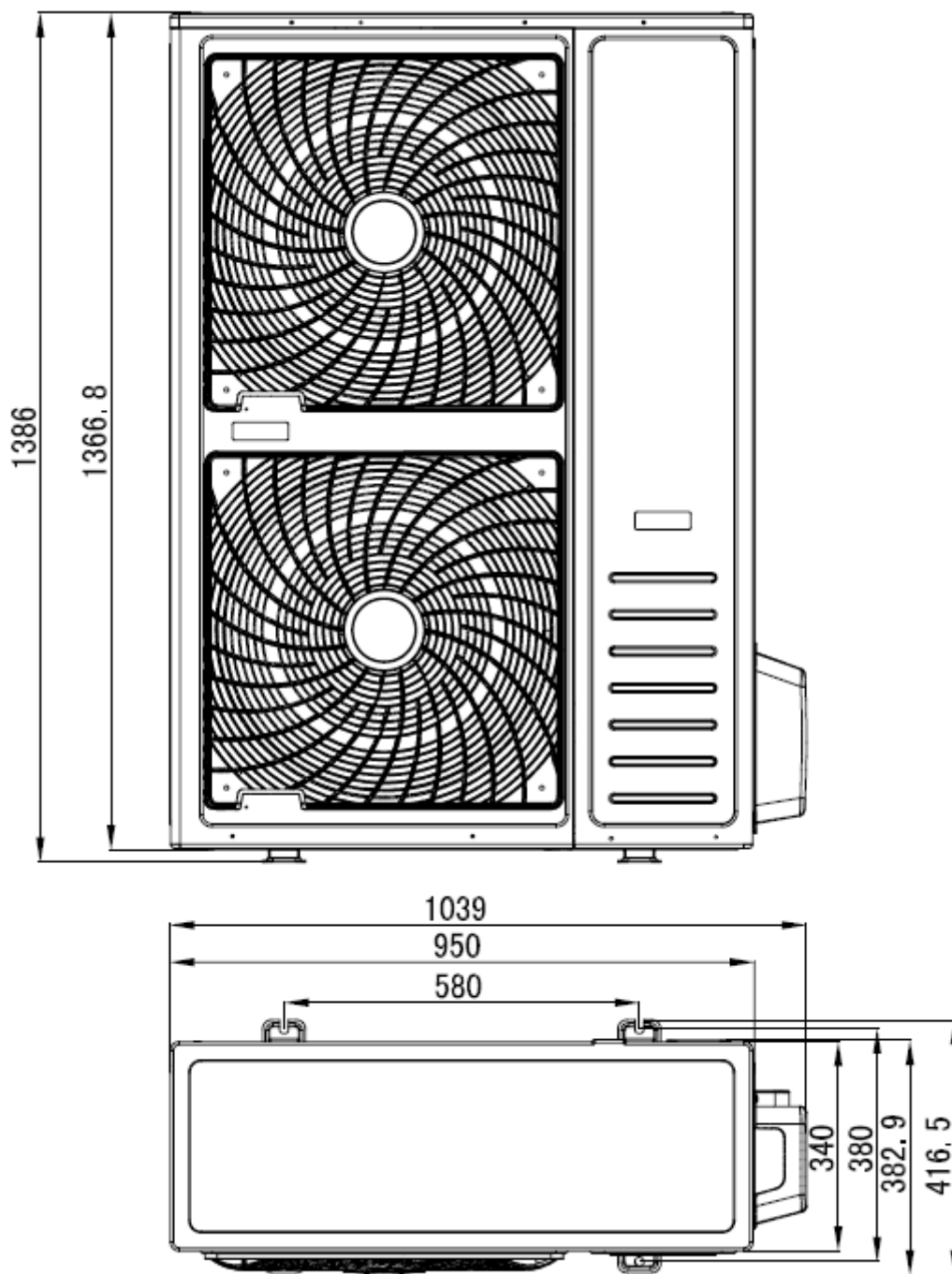

4. DIAGRAM&DATA

4. Diagrams&DATA

4.1 Piping Diagrams

18k type

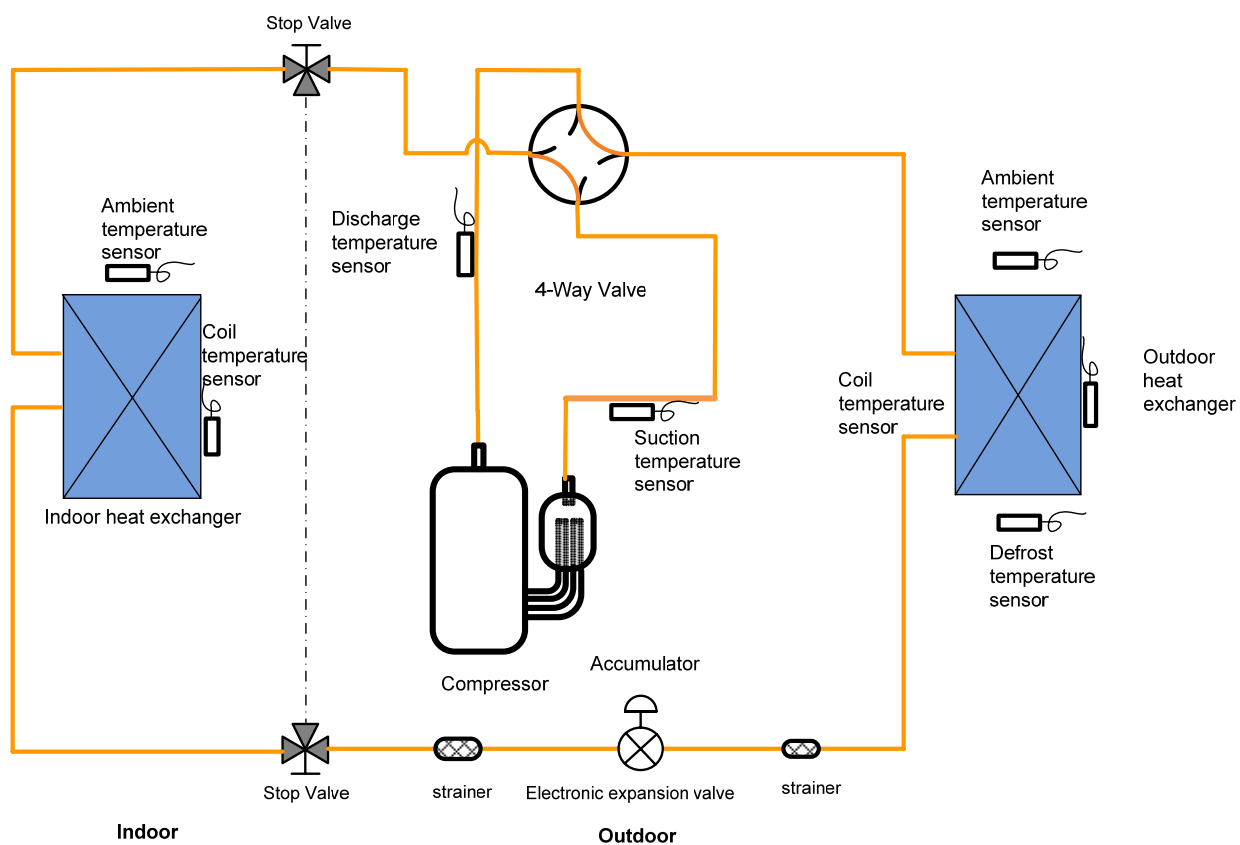

4. DIAGRAM&DATA

24k &36K type

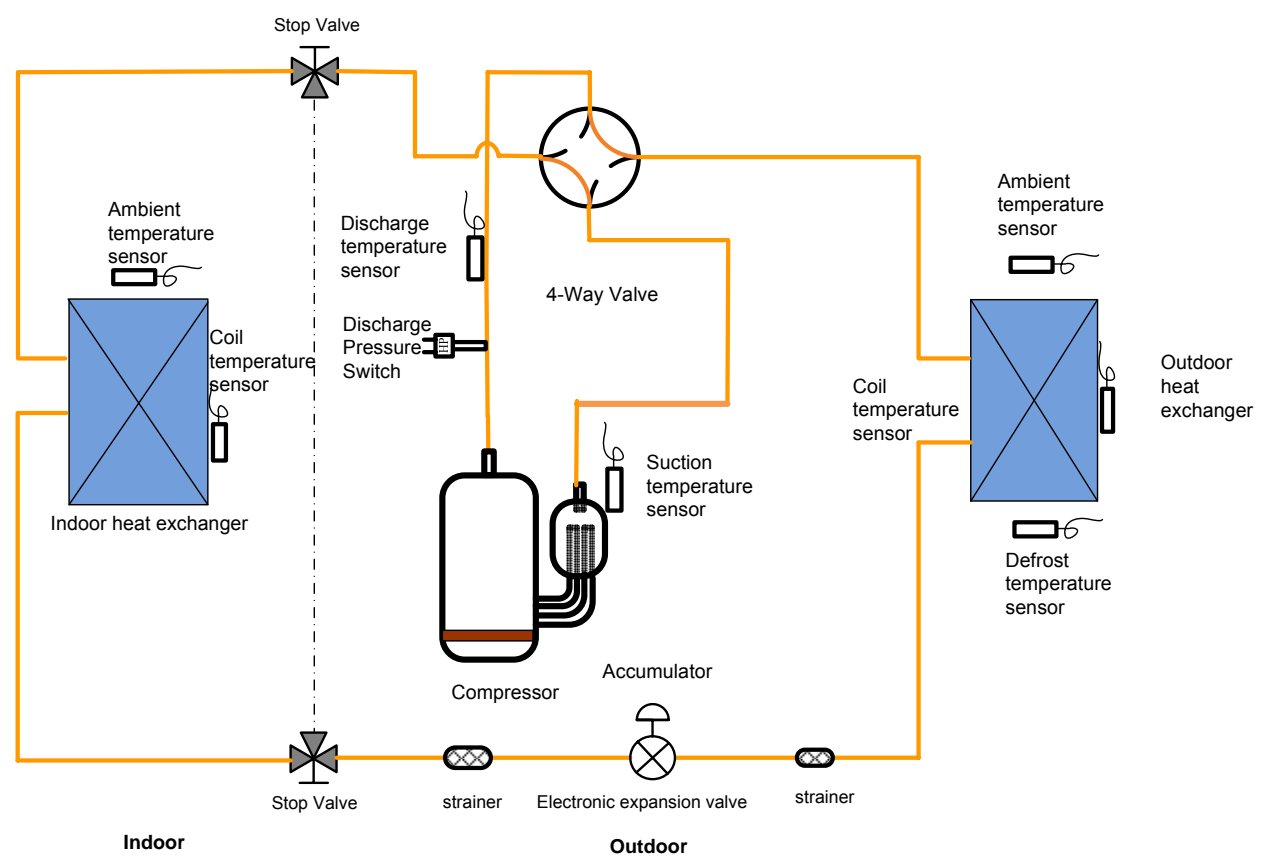

4. DIAGRAM&DATA

48K&60K

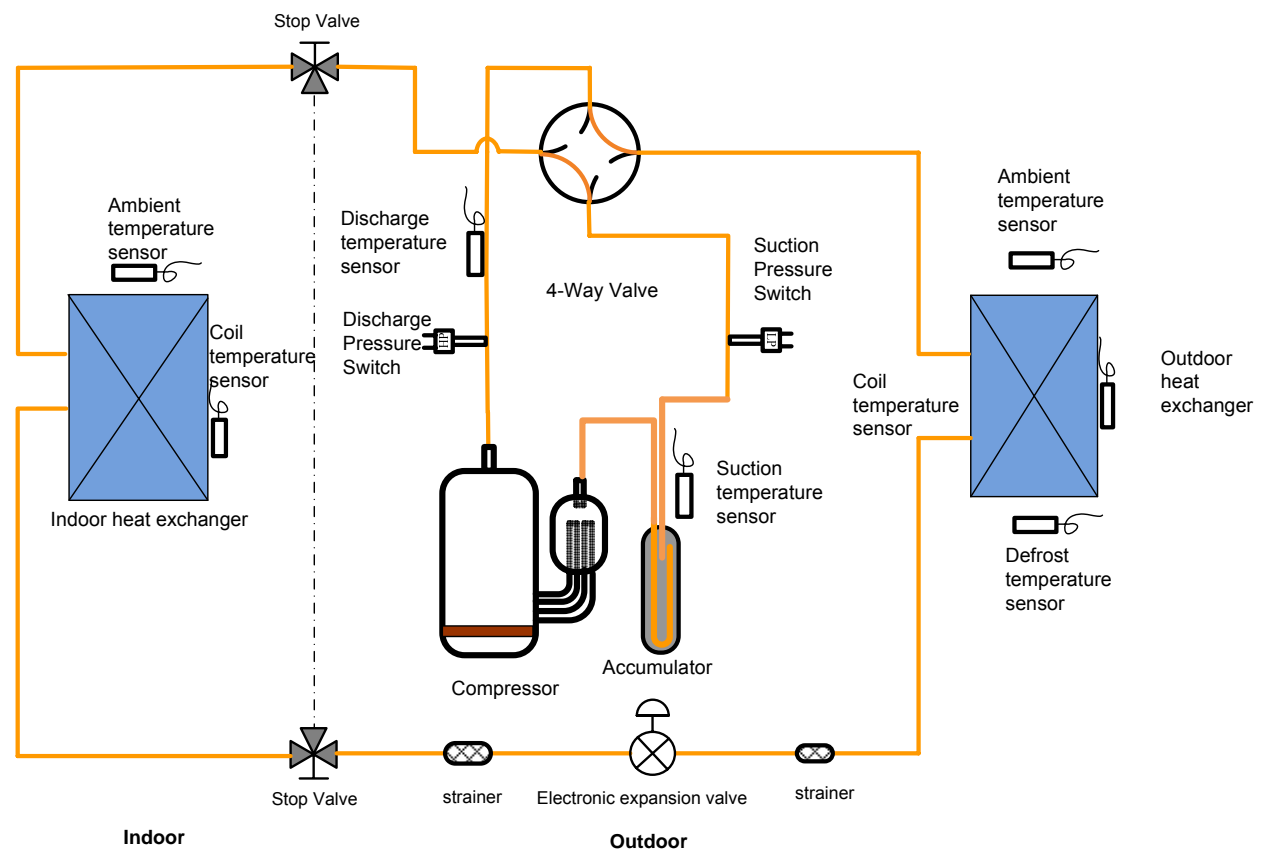

4. DIAGRAM&DATA

4-2MAX. Refrigerant pipe length and height difference

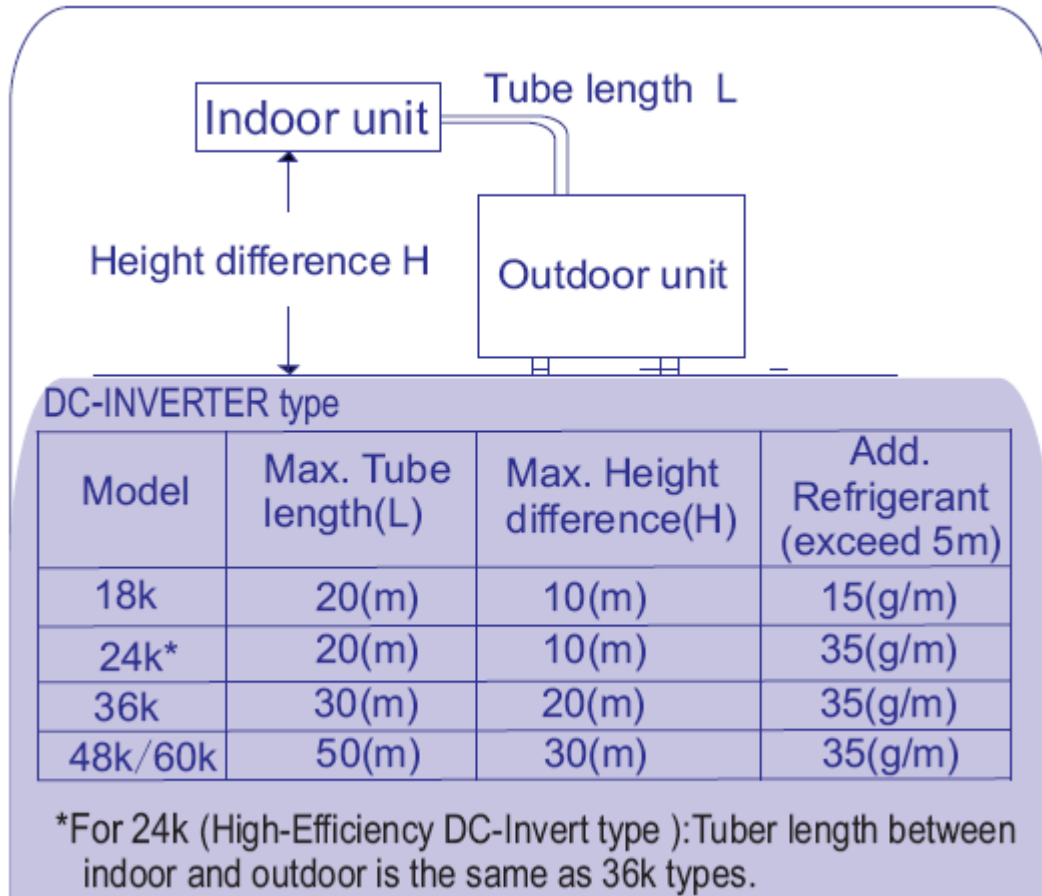

*Do your best to reduce the pipe length. Long pipe may cause capacity of the indoor unit incline.

Outdoor unit precharged		Total refrigerant pipe length	
		0m~5m	5m~60m
AUW-18U4SG	1270g	0g	$Xg = 15g / m \times (\text{Total pipe length}(m) - 5)$
AUW-24U4SZ	1500g	0g	
AUW-36U4SA	2100g	0g	
AUW-18U4SZ1	1400g	0g	
AUW-24U4SA1	1680g	0g	$Xg = 35g / m \times (\text{Total pipe length}(m) - 5)$
AUW-36U4SA1	2100g	0g	
AUW-48U6SP	3000g	0g	
AUW-60U6SP	3500g	0g	

4. DIAGRAM&DATA

4-3ELECTRIC Diagrams

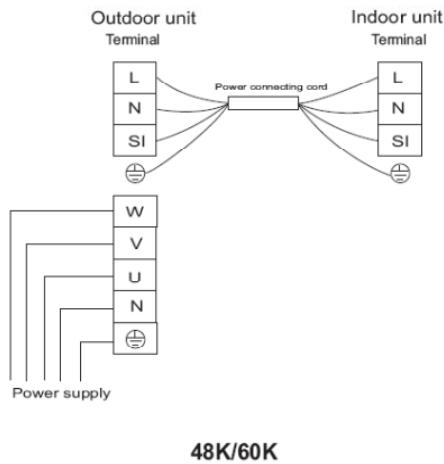
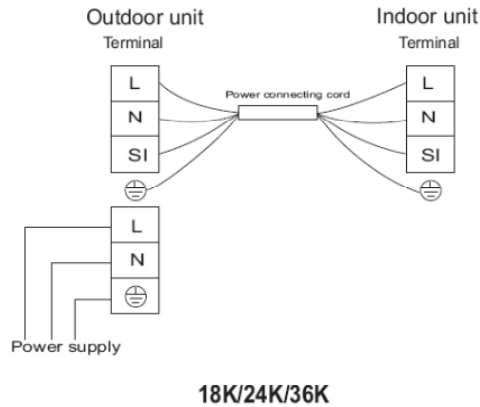

Recommend Wire Size

Model	POWER SUPPLY	Power Source Cable Size (mm ²)	Transmitting Cable Size (mm ²)
18K	220-240V, 50Hz	3×1.5	4×0.75
24K/36K	220-240V, 50Hz	3×2.5	4×0.75
48K/60K	380~415V, 3N~, 50Hz	5×2.5	4×0.75

- Use an ELB (Electric Leakage Breaker). If not used, it will cause an electric shock or a fire.
 - Do not operate the system until all the check points have been cleared.
- (A) Check to ensure that the insulation resistance is more than 1 megohm, by measuring the resistance between ground and the terminal of the electrical parts. If not, do not operate the system until the electrical leakage is found and repaired.

4. DIAGRAM&DATA

(B) Check to ensure that the stop valves of the outdoor unit are fully opened and then start the system.

- Pay attention to the following items while the system is running.

(A) Do not touch any of the parts by hand at the discharge gas side, since the compressor chamber and the pipes at the discharge side are heated higher than 90°C.

(B) DO NOT PUSH THE BUTTON OF THE MAGNETIC SWITCH(ES). It will cause a serious Accident.

NOTES:

- 1) Follow local codes and regulations when selecting field wires.
- 2) The wire sizes marked in the table are selected at the maxim current of the unit according to the European Standard ,En60 335-1. Use the wires which are not lighter than the ordinary tough rubber sheathed flexible cord (code designation H07RN-F) or ordinary polychloroprene sheathed flexible cord (code designation H07RN-F) .
- 3) Use a shielded cable for the transmitting circuit and connect it to ground .
- 4) In the case that power cables are connected in series, add each unit maximum current and select wires below.

Selection According to EN60 335-1

Current i (A)	Wire Size (mm²)
$i \leq 6$	0.75
$6 < i \leq 10$	1
$10 < i \leq 16$	1.5
$16 < i \leq 25$	2.5
$25 < i \leq 32$	4
$32 < i \leq 40$	6
$40 < i \leq 63$	10
$63 < i$	*3

* in the case that current exceeds 63A, do not connect cables in series.

4. DIAGRAM&DATA

4-4Air flow and ESP Chart Diagrams(for duct type)

18K

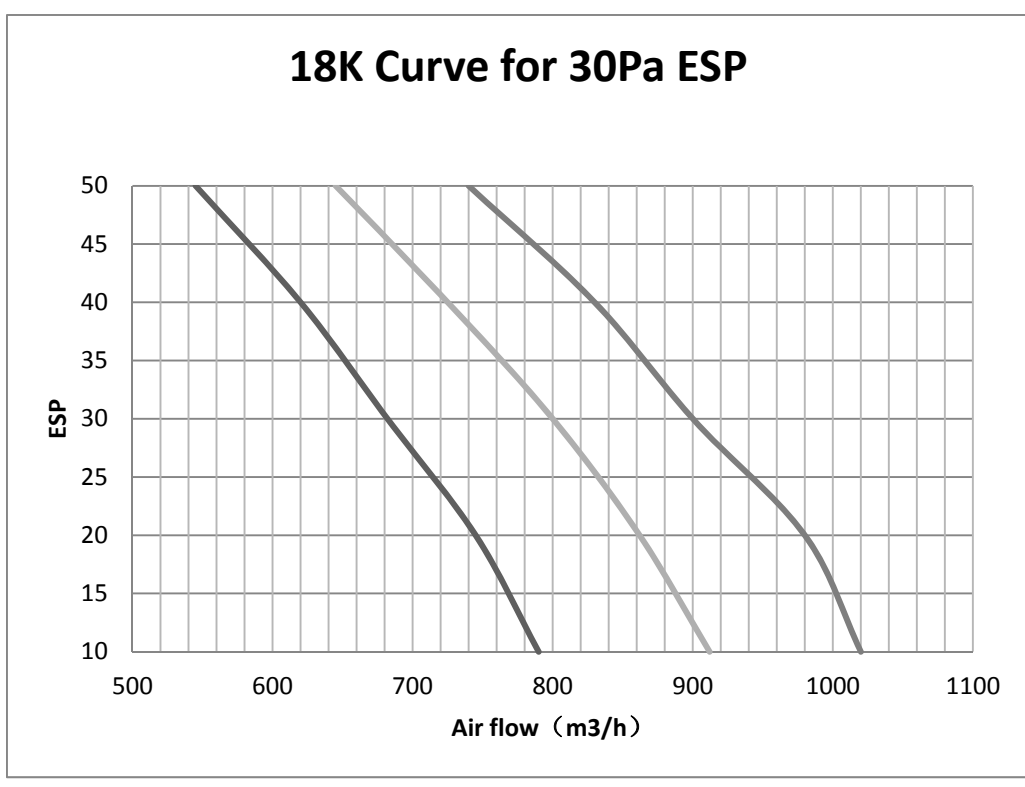
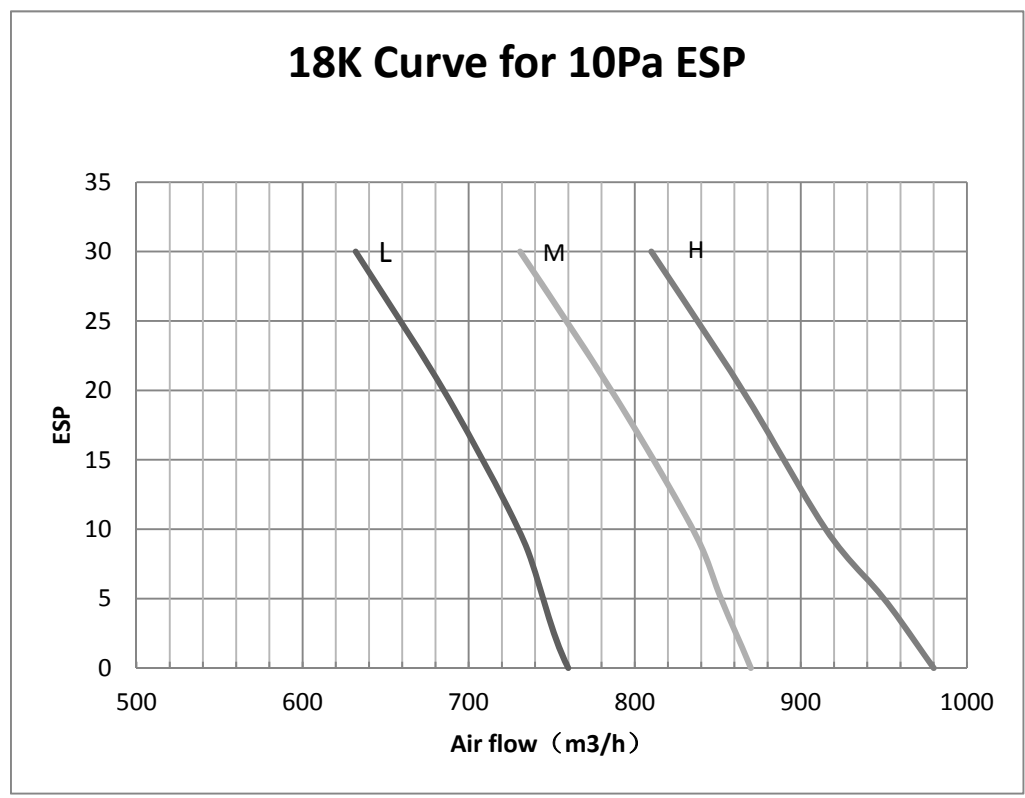

24K

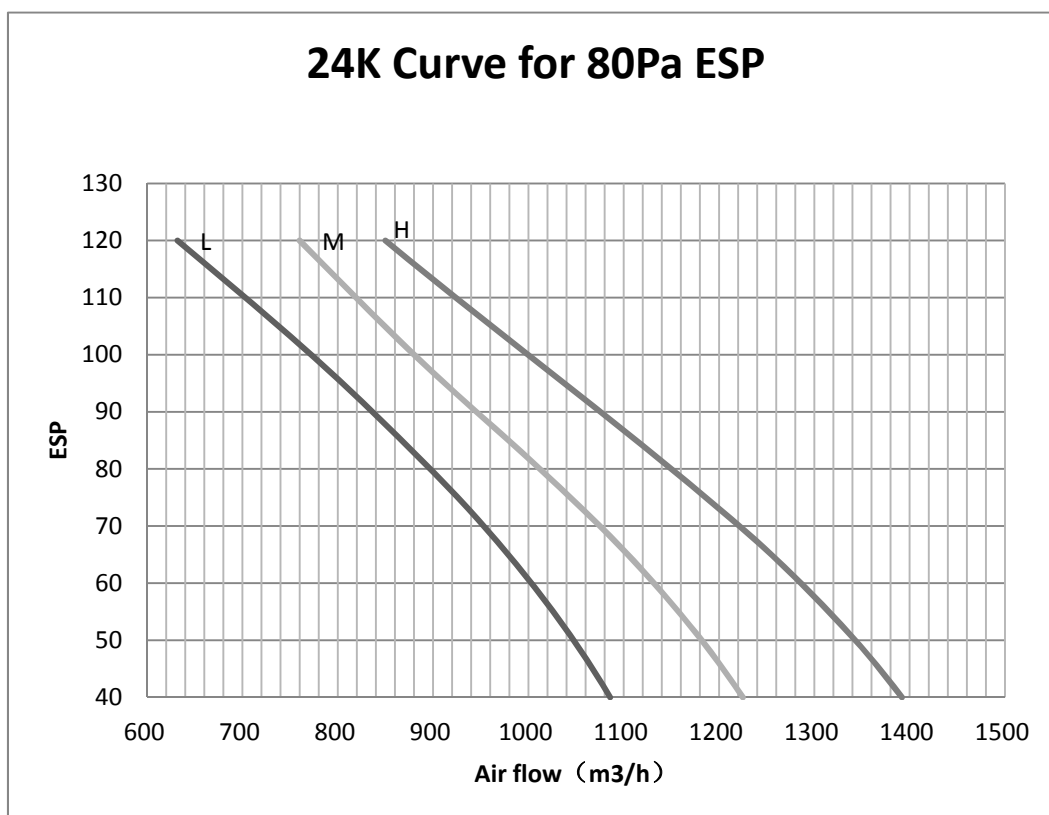
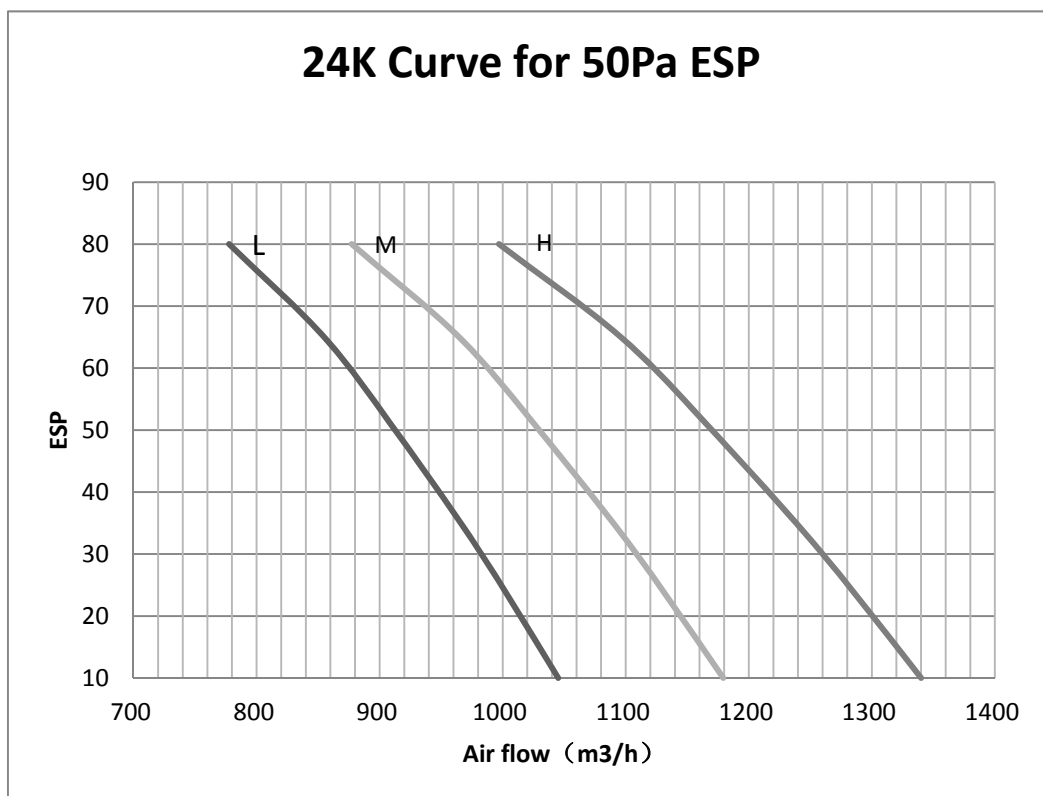

36K (AC MOTOR)

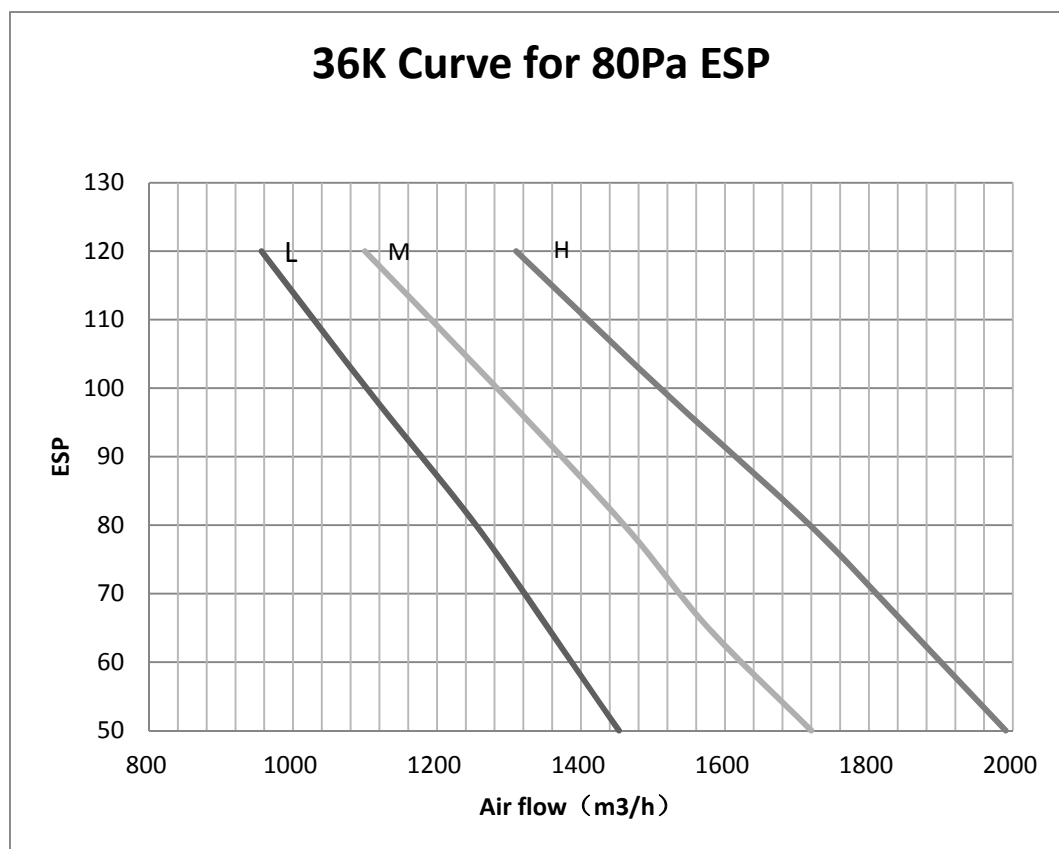
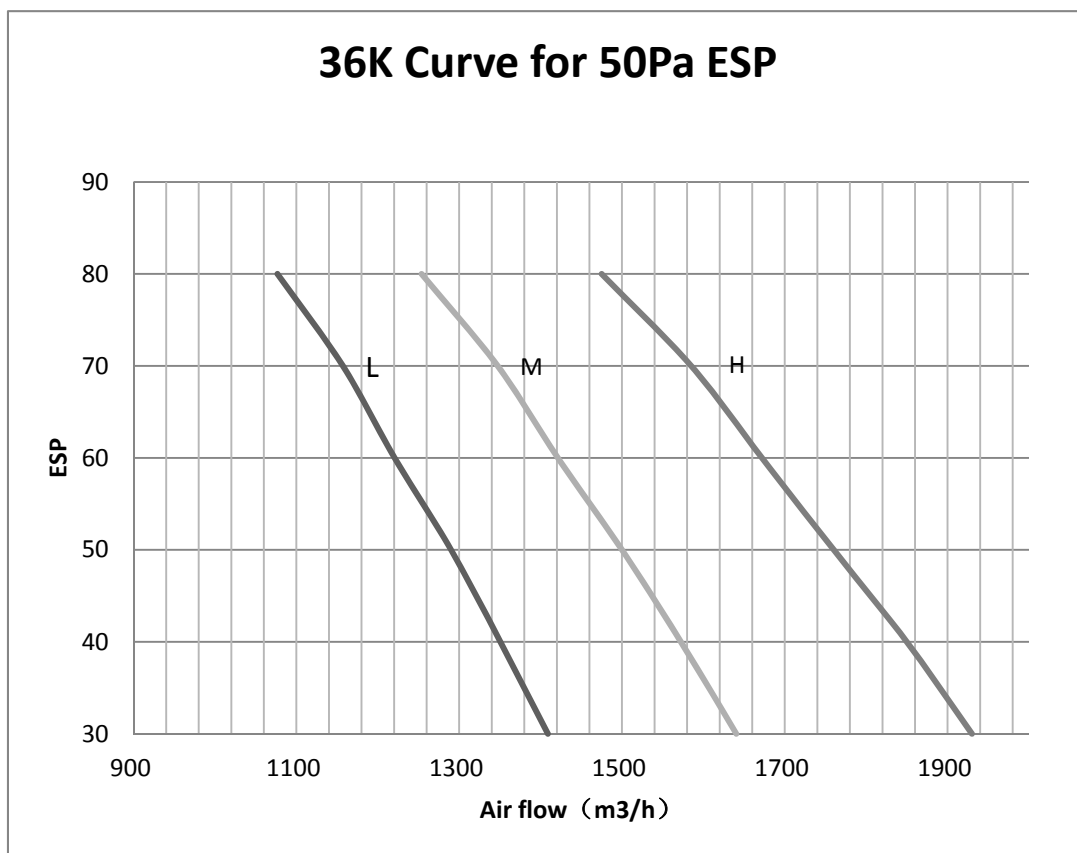

48K

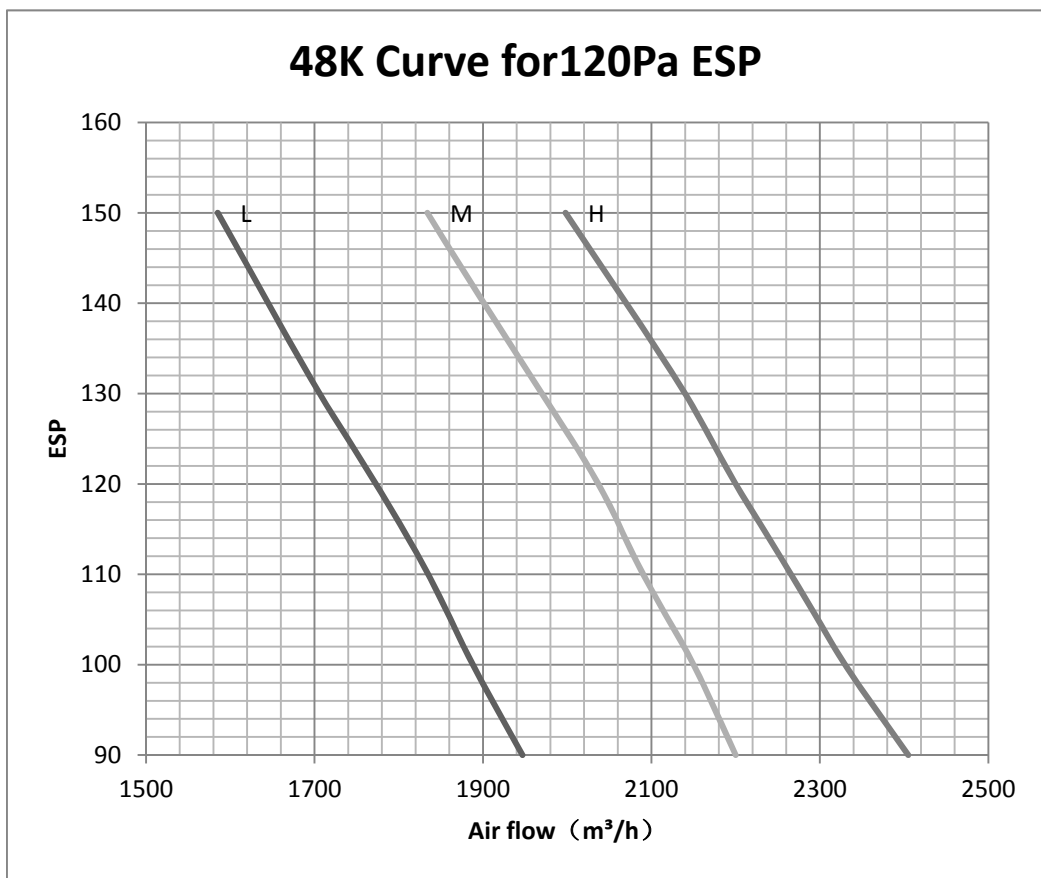
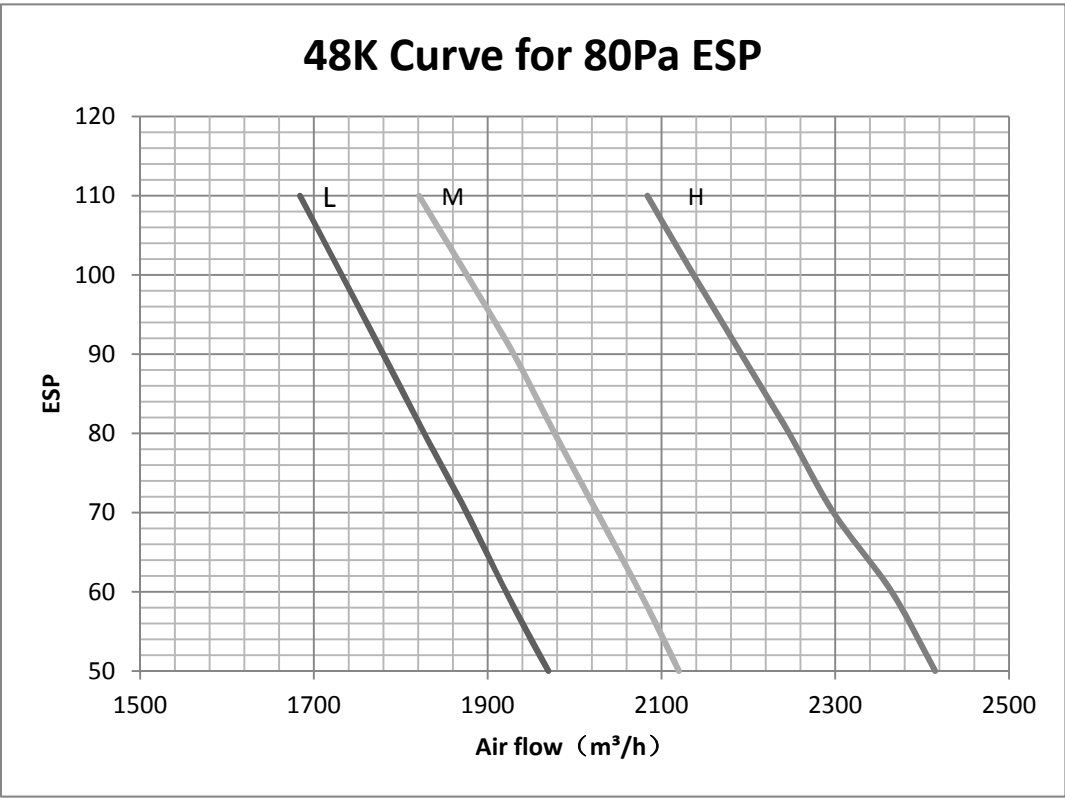

60K

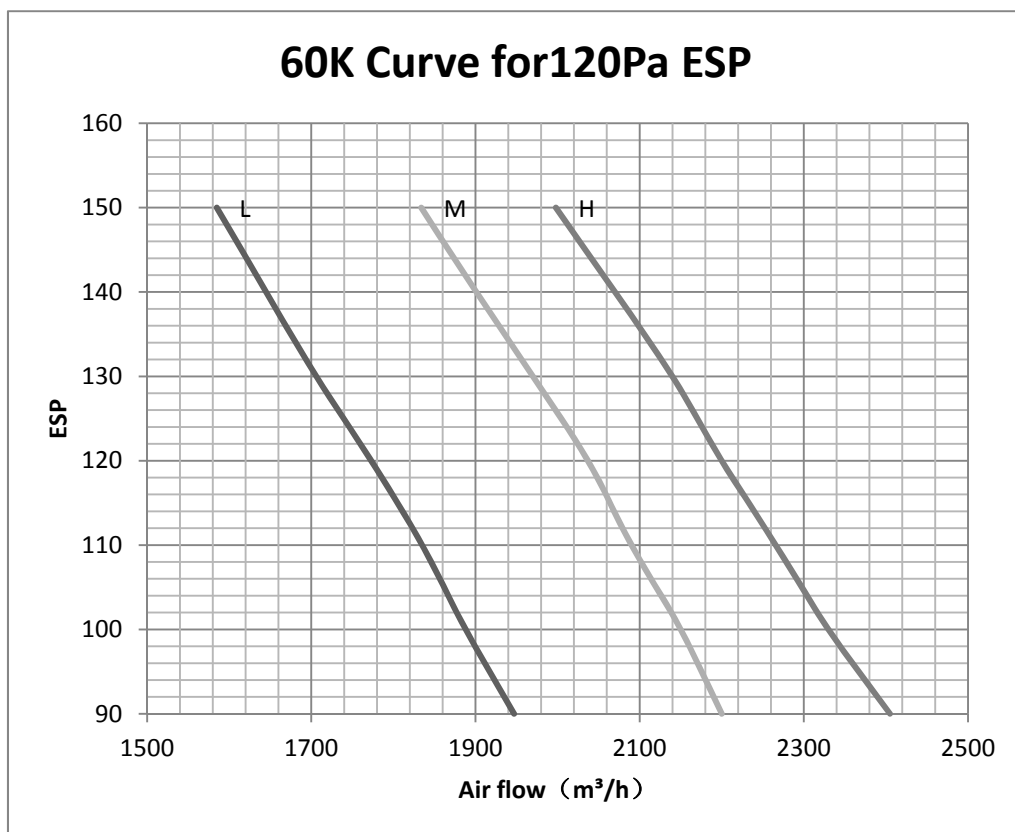
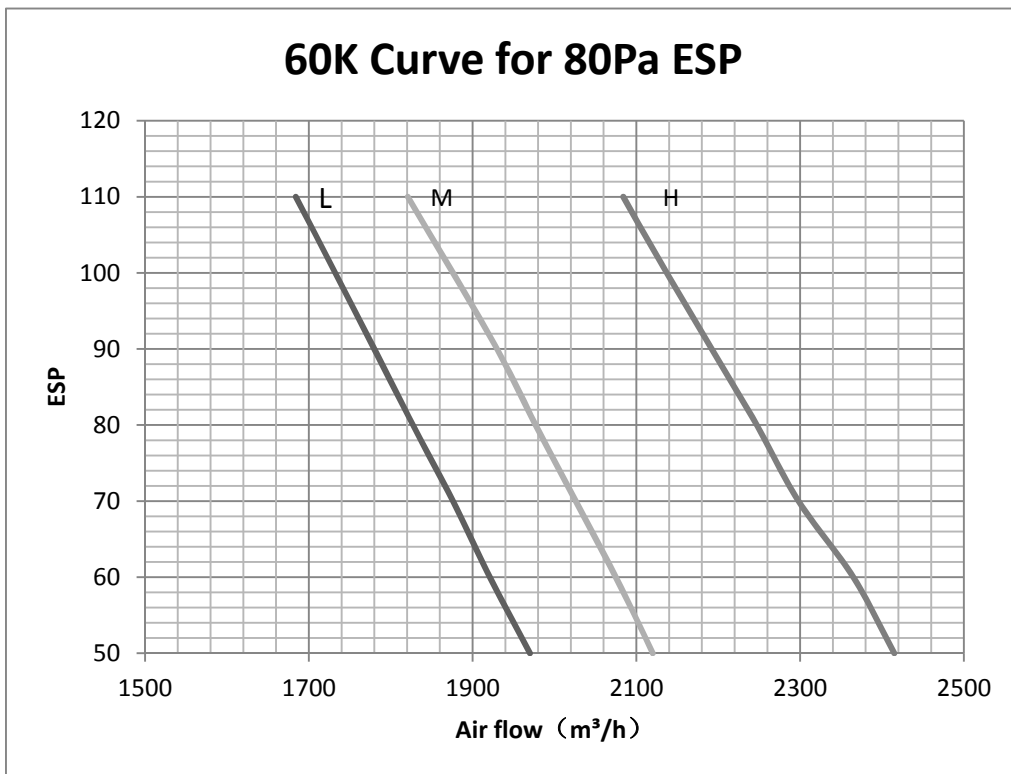

4. DIAGRAM&DATA

4.5 PERFORMANCE CURVE

18K Cooling Capacity

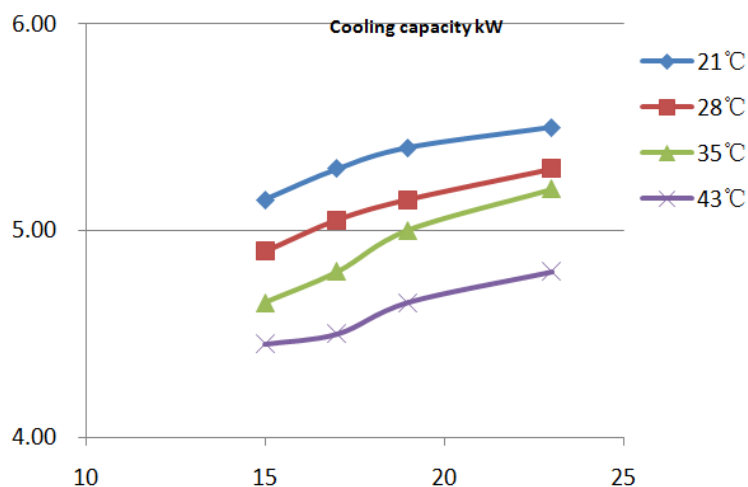

24K Cooling Capacity

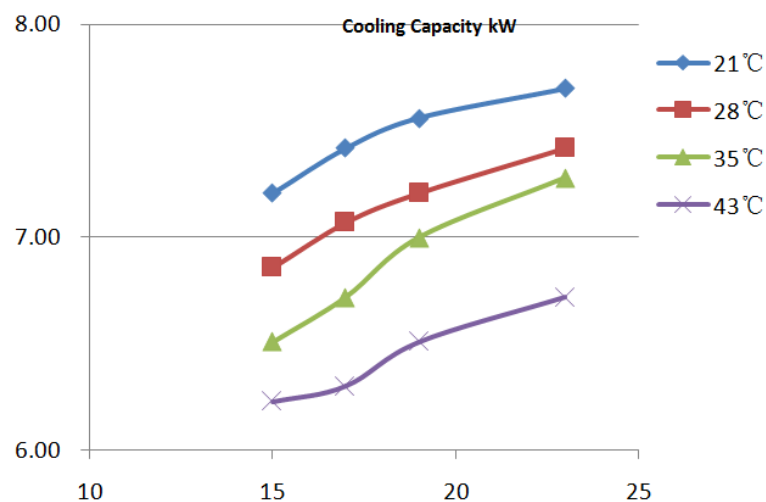

36K Cooling Capacity

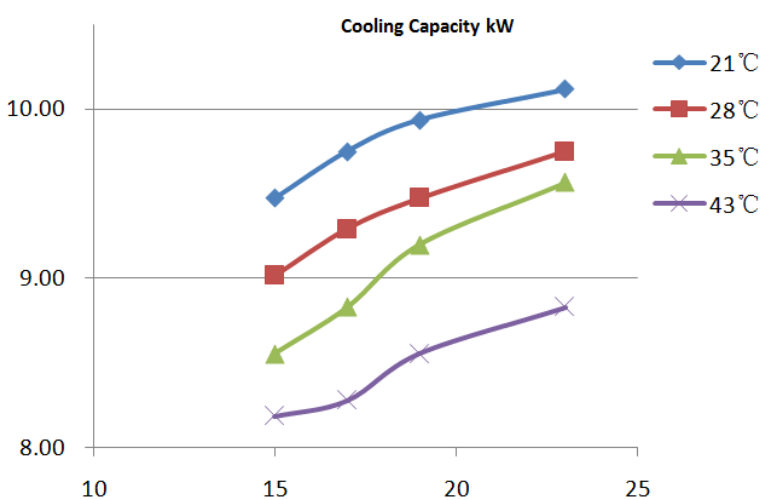

4. DIAGRAM&DATA

48K

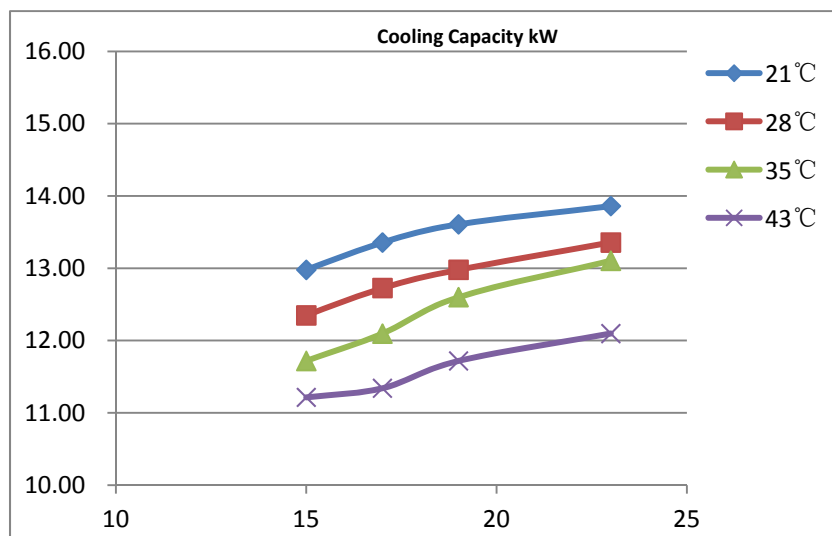

60k

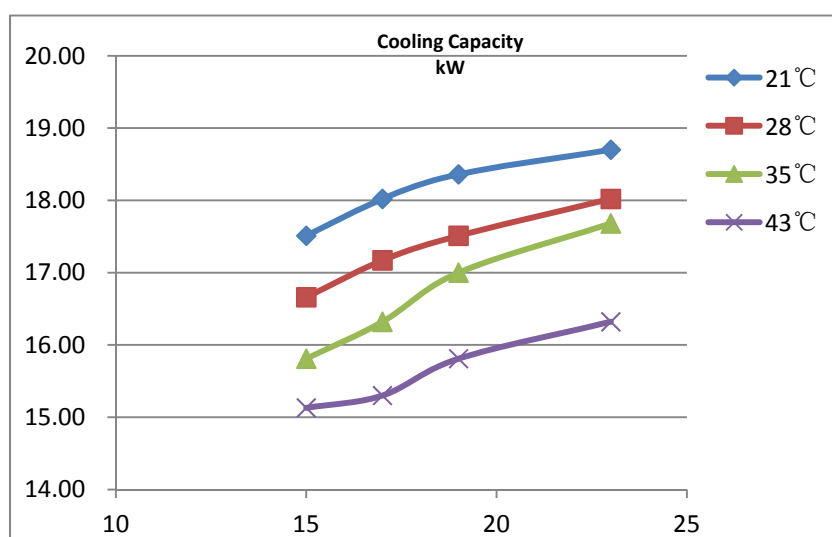

5. ELECTRICAL DATA

5-1. Electrical wiring diagrams

INDOOR UNIT

Duct type

AUD-18UX4SKL,AUD-18UX4SKL1

Electrical Wiring Diagram 1812813.A

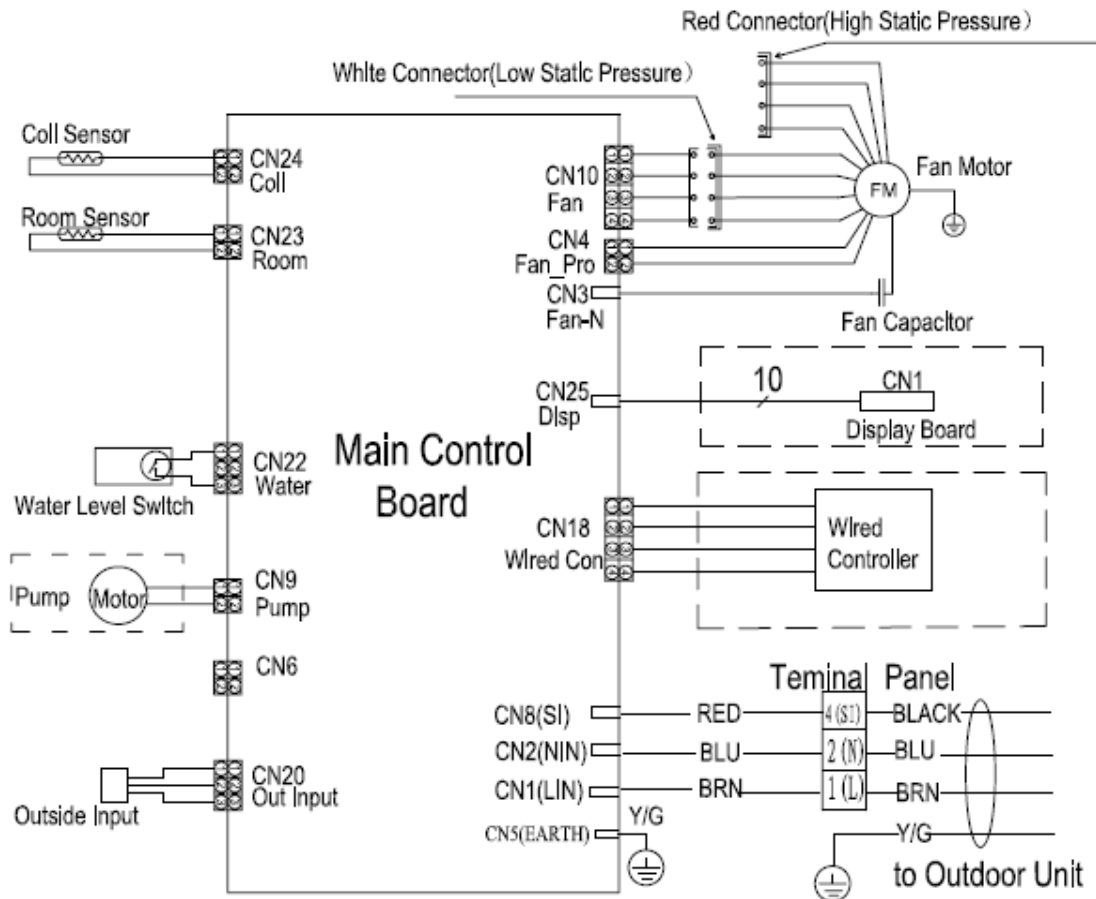

Attention:

1. The fan motor connection mode has been set by its product factory. Please according to specification to connect different static pressure connector.

5. ELECTRICAL DATA

AUD-24UX4SLH,AUD-36UX4SMH

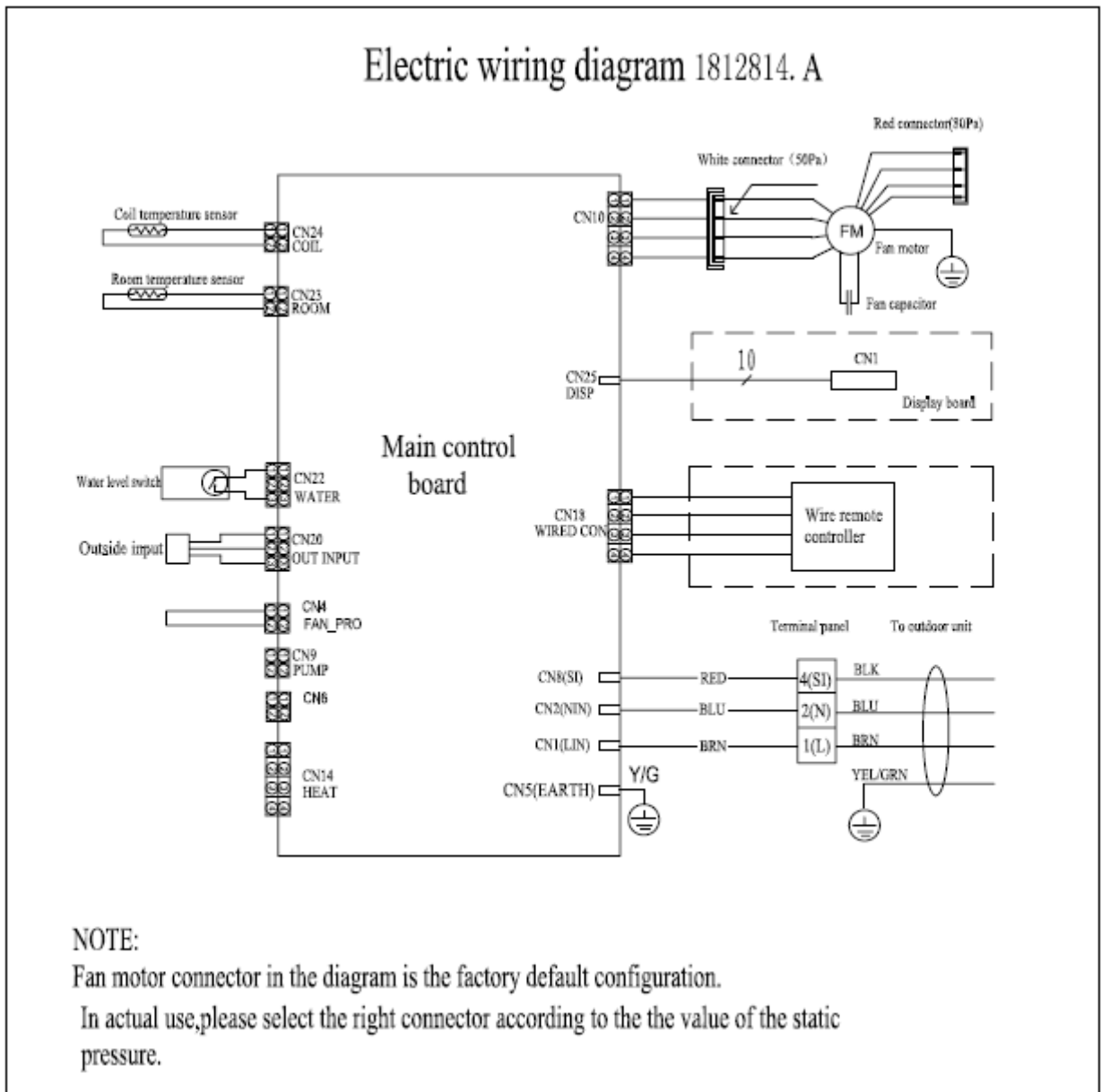

5. ELECTRICAL DATA

AUD-24U4SLH1,AUD-36U4SMH1

Electric wiring diagram 1806500. A

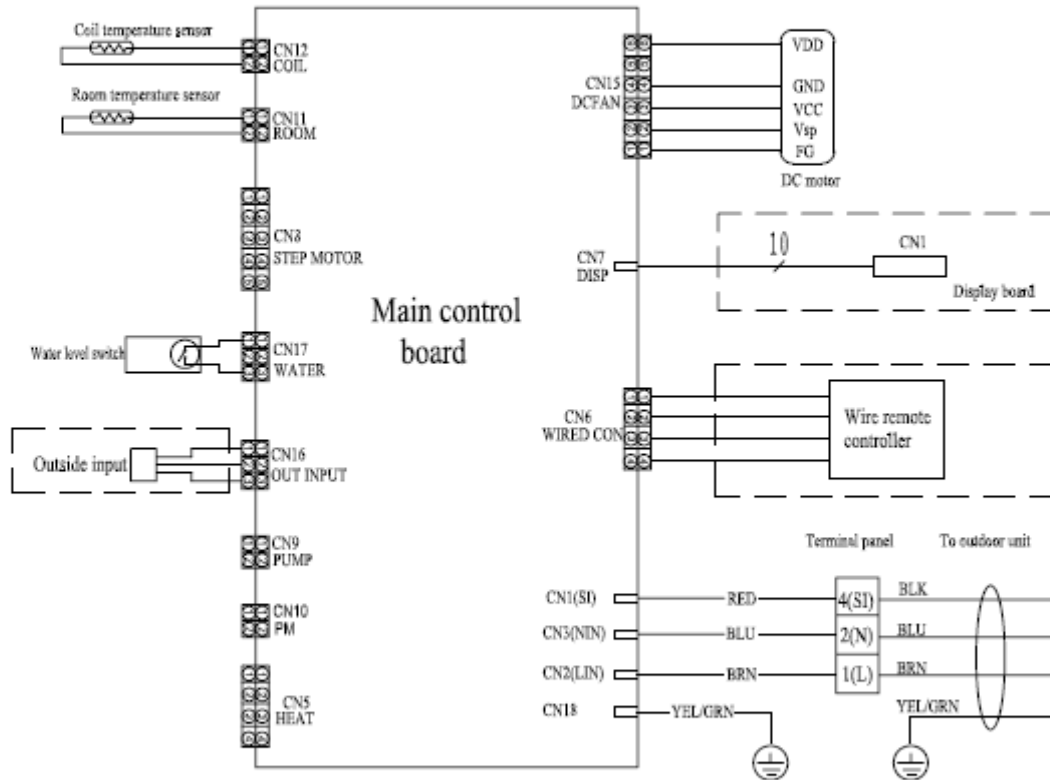

5. ELECTRICAL DATA

AUD-48UX4SHH,AUD-60UX4SHH

Electric wiring diagram 1812823. A

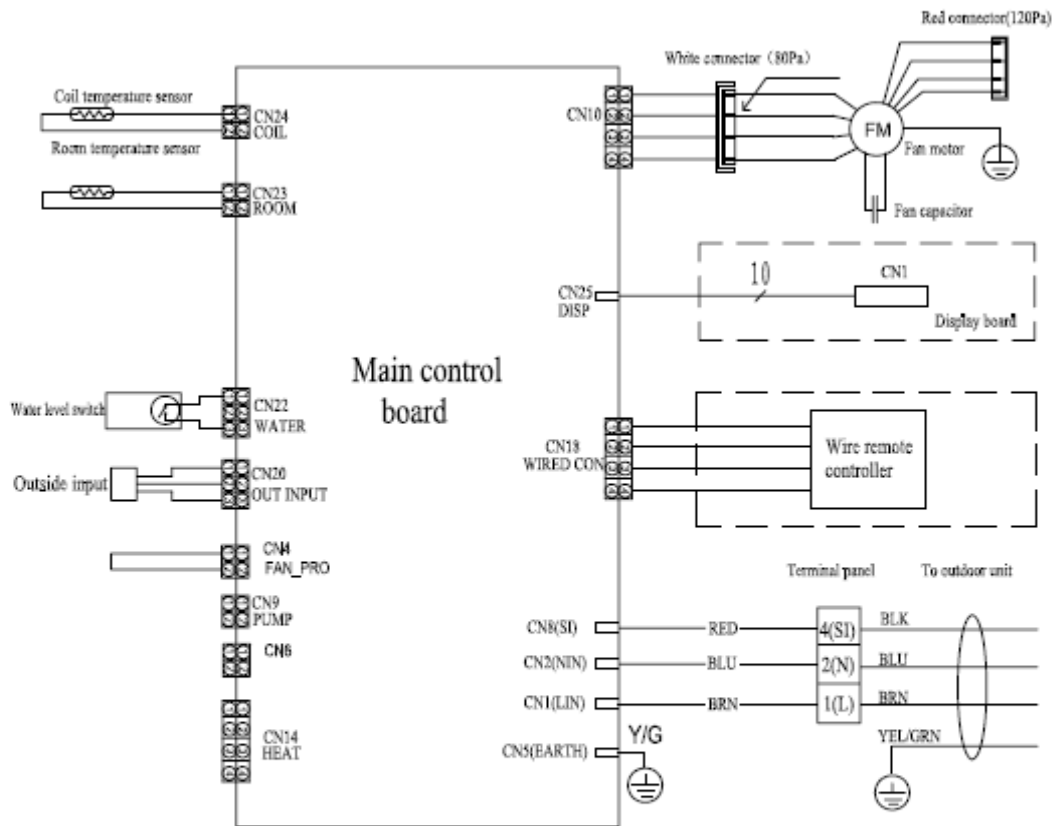

NOTE:

Fan motor connector in the diagram is the factory default configuration.

In actual use, please select the right connector according to the value of the static pressure.

5. ELECTRICAL DATA

Cassette type

18k

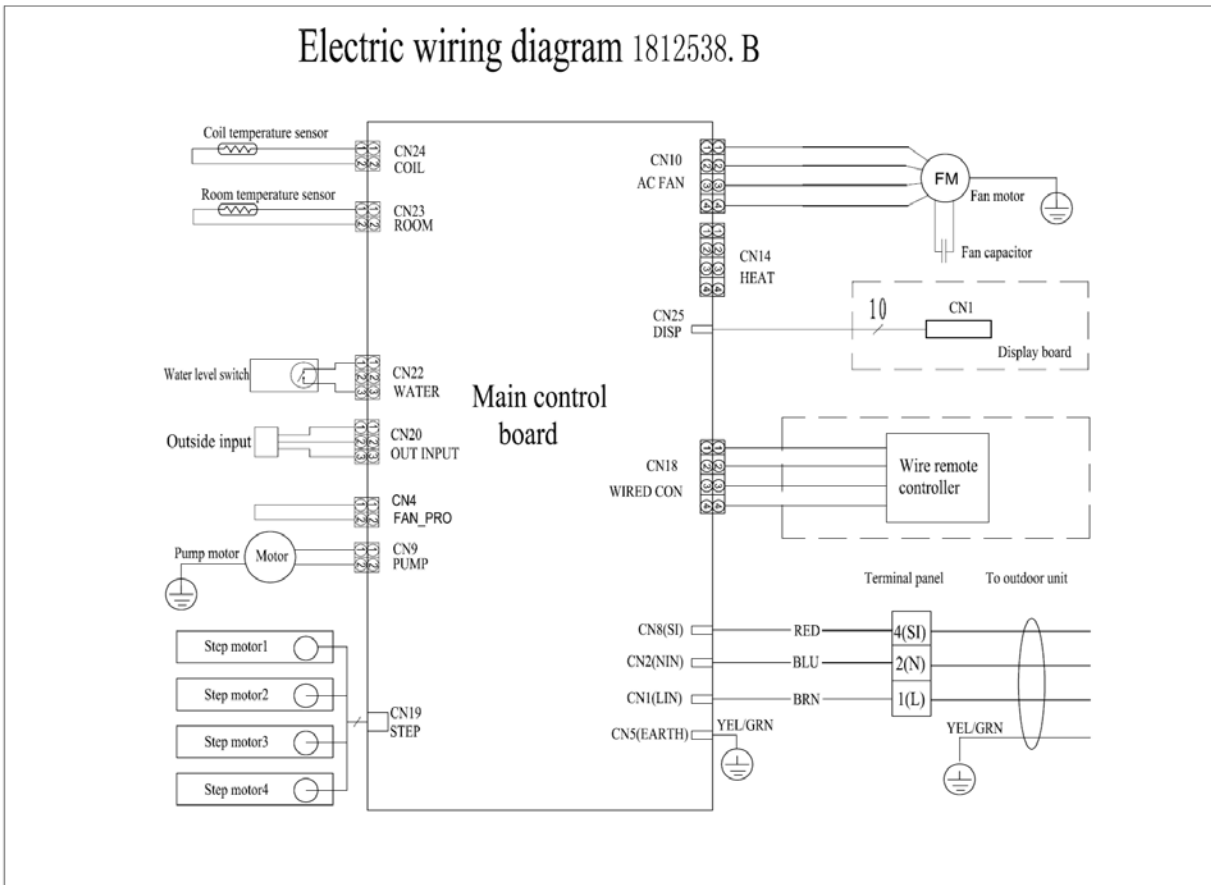

24K ,36K,48K,60K

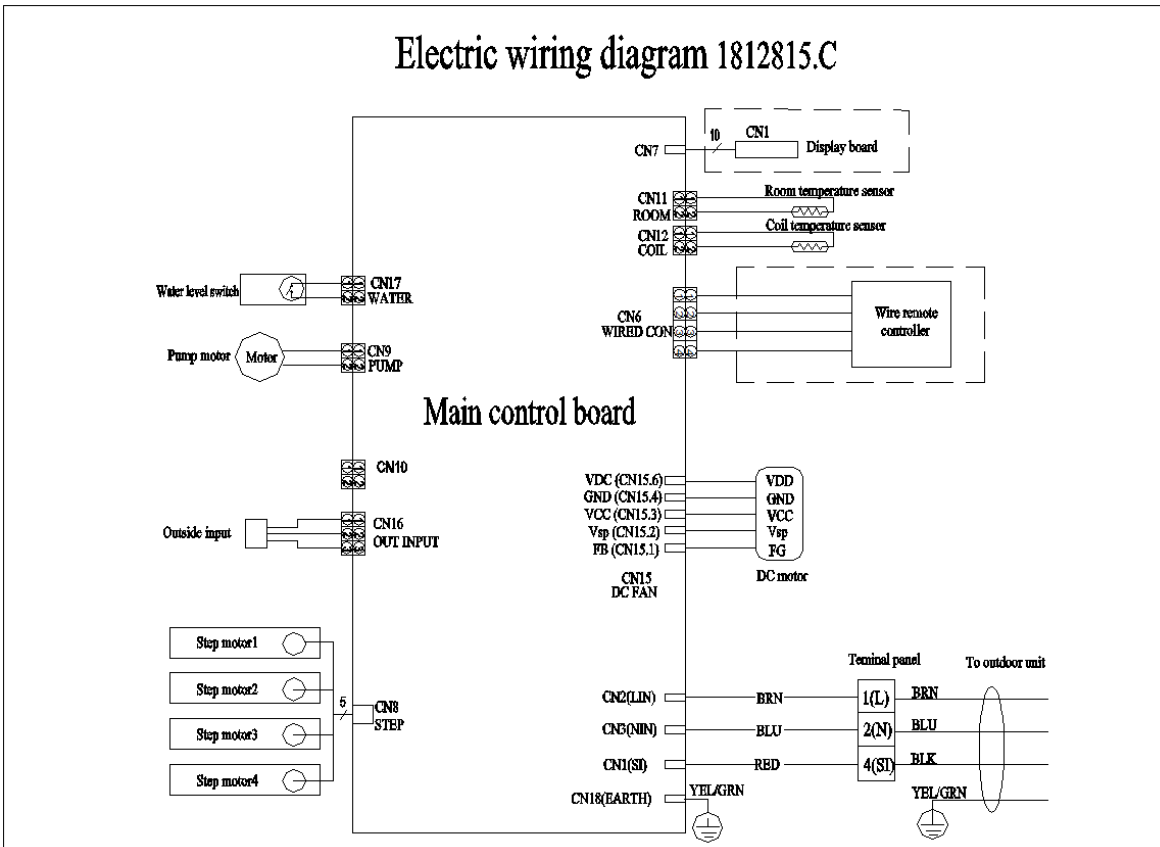

5. ELECTRICAL DATA

Ceiling&Floor type
18K,48K,60K

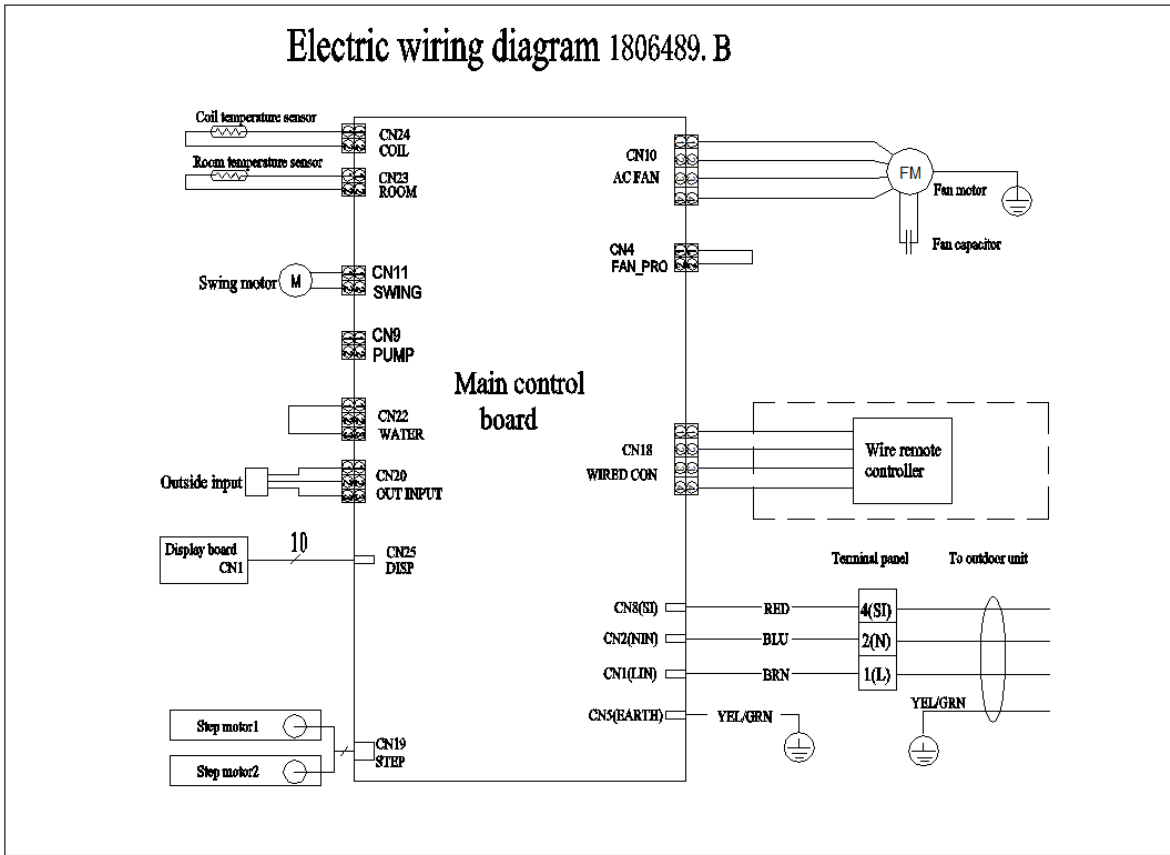

24K,36K

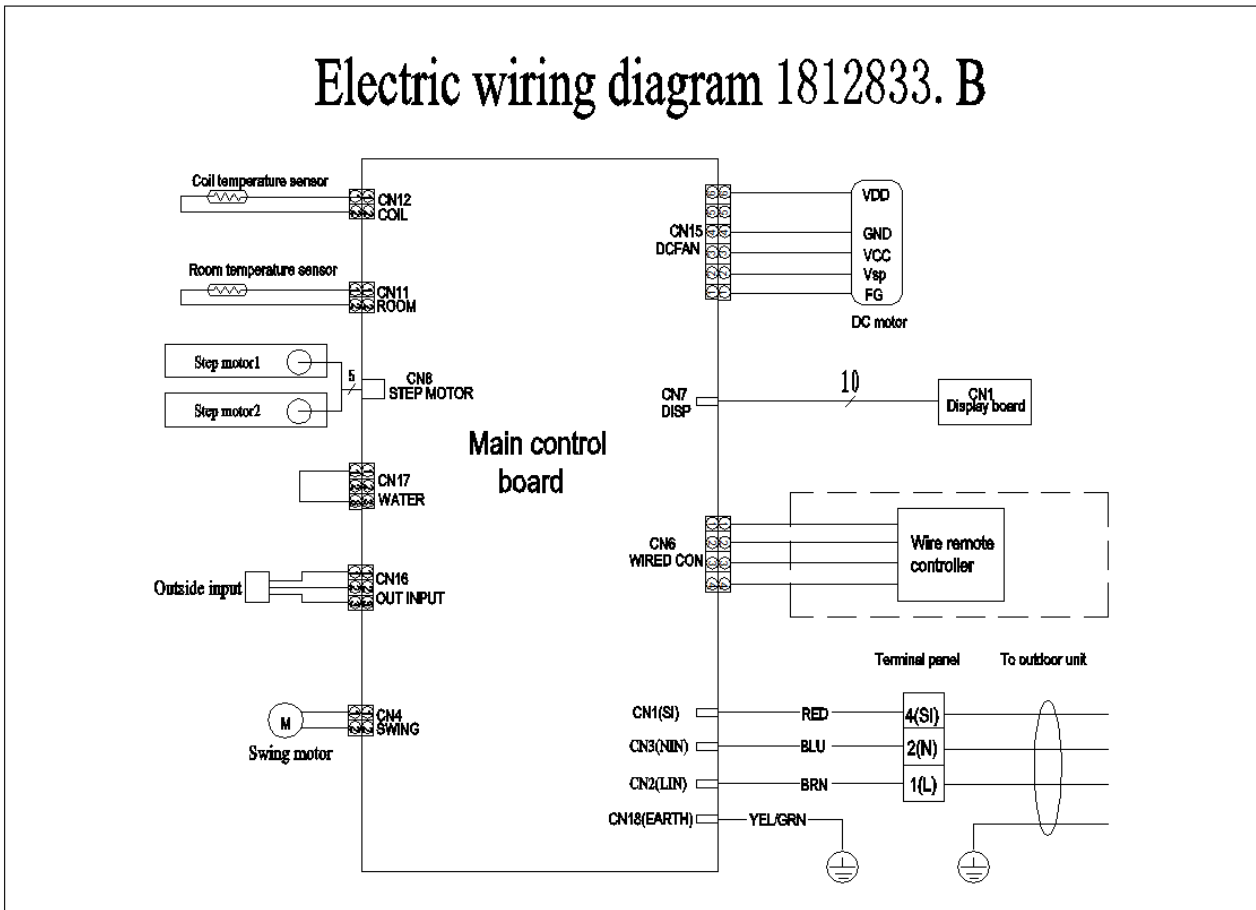

5. ELECTRICAL DATA

OUTDOOR UNIT
18K
AUW-18U4SG

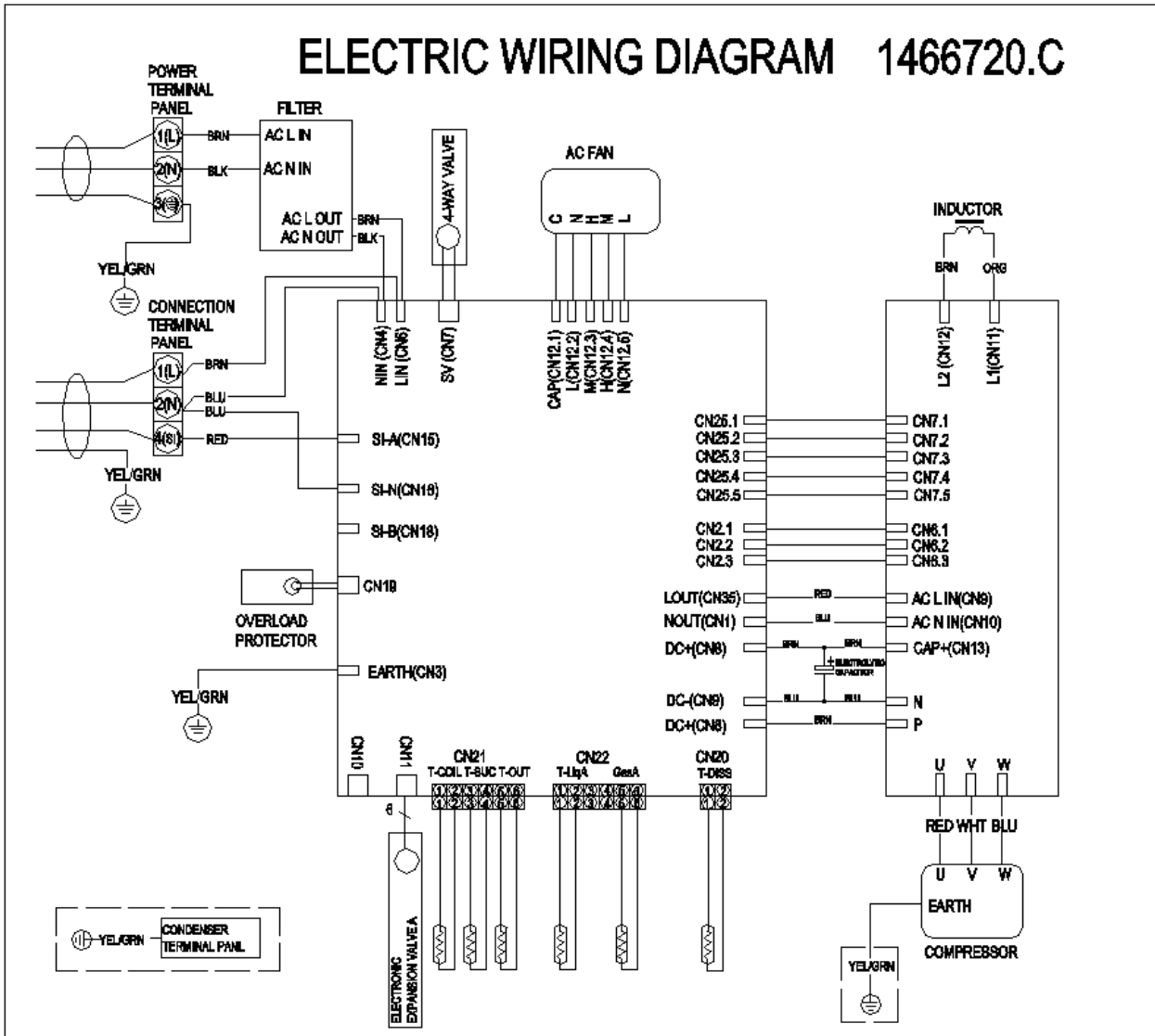

5. ELECTRICAL DATA

AUW-18U4SZ1

Electric Wiring Diagram 1518965.B

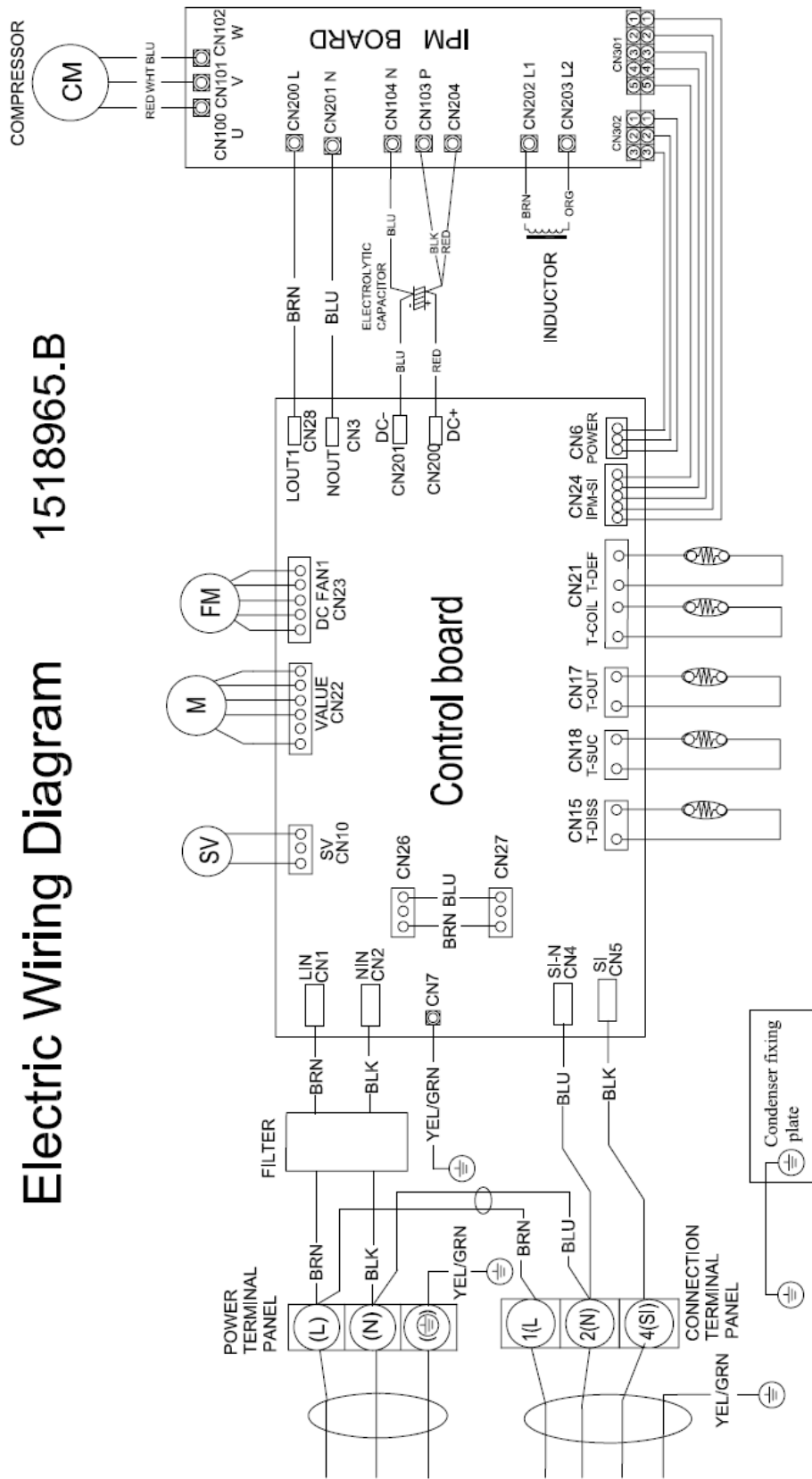

5. ELECTRICAL DATA

24K
AUW-24U4SZ

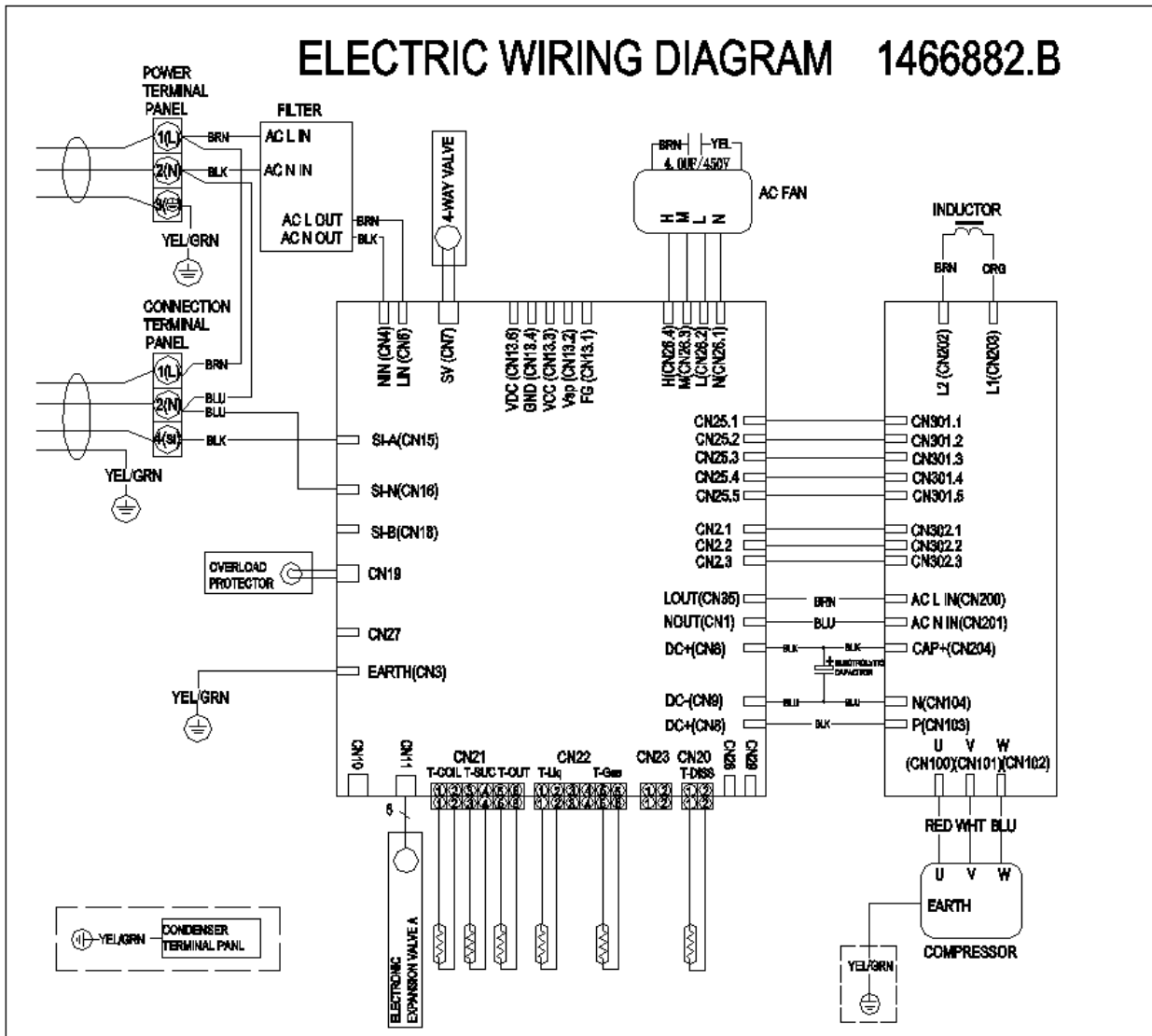

5. ELECTRICAL DATA

AUW-24U4SA1

Electric Wiring Diagram 1519694.B

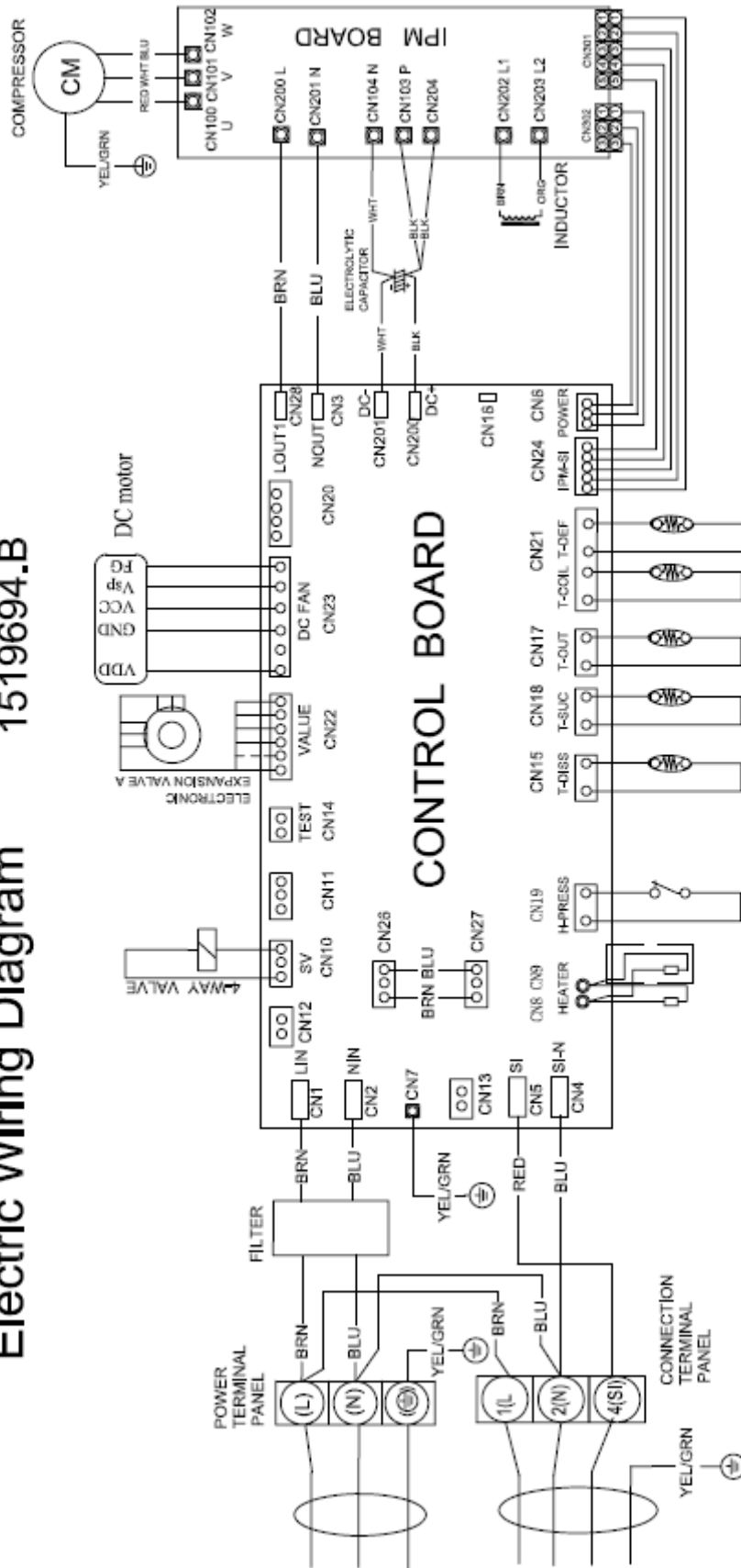

5. ELECTRICAL DATA

36K
 AUW-36U4SA

Electric Wiring Diagram 1457535.B

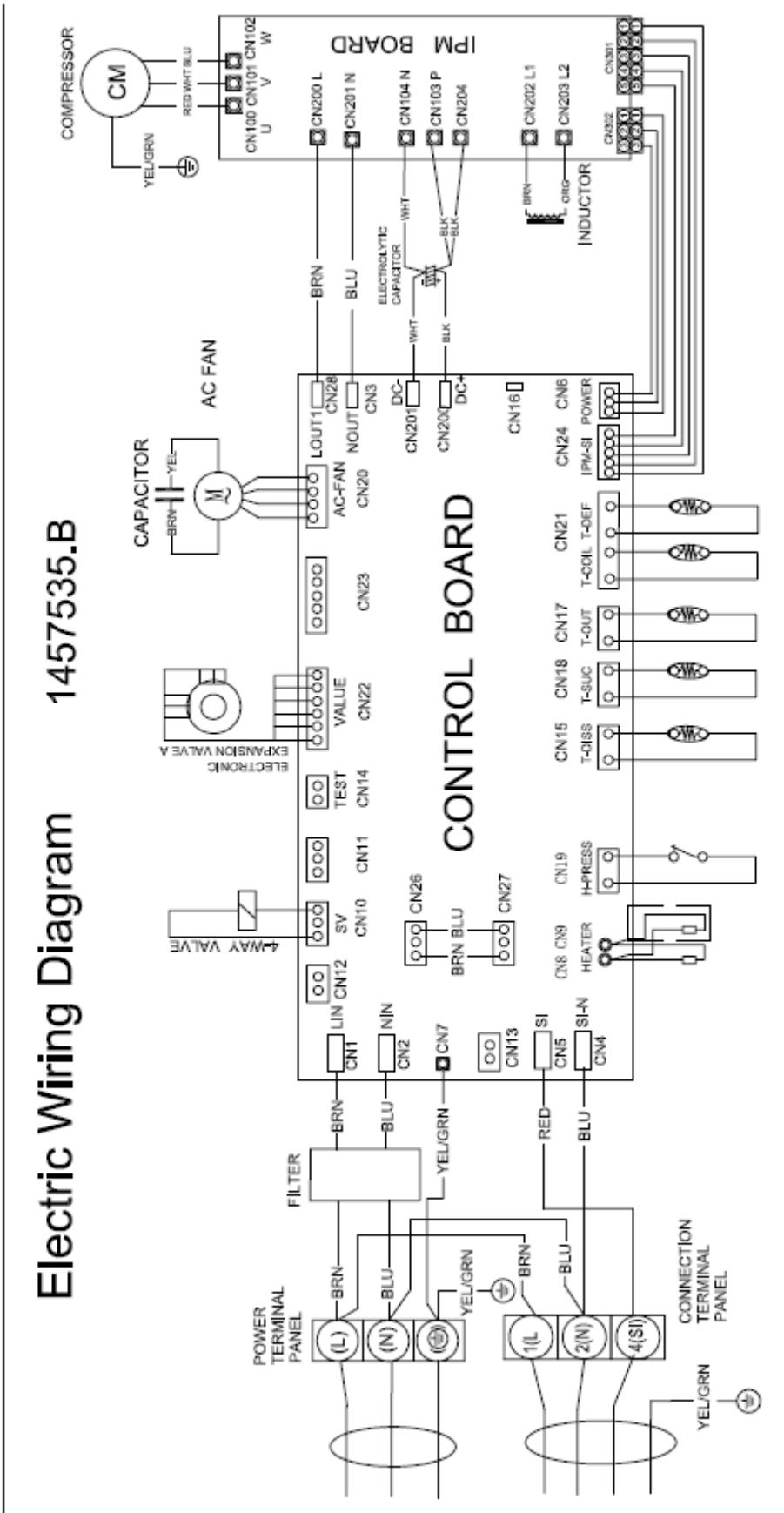

5. ELECTRICAL DATA

AUW-36U4SA1

Electric Wiring Diagram 1519694.B

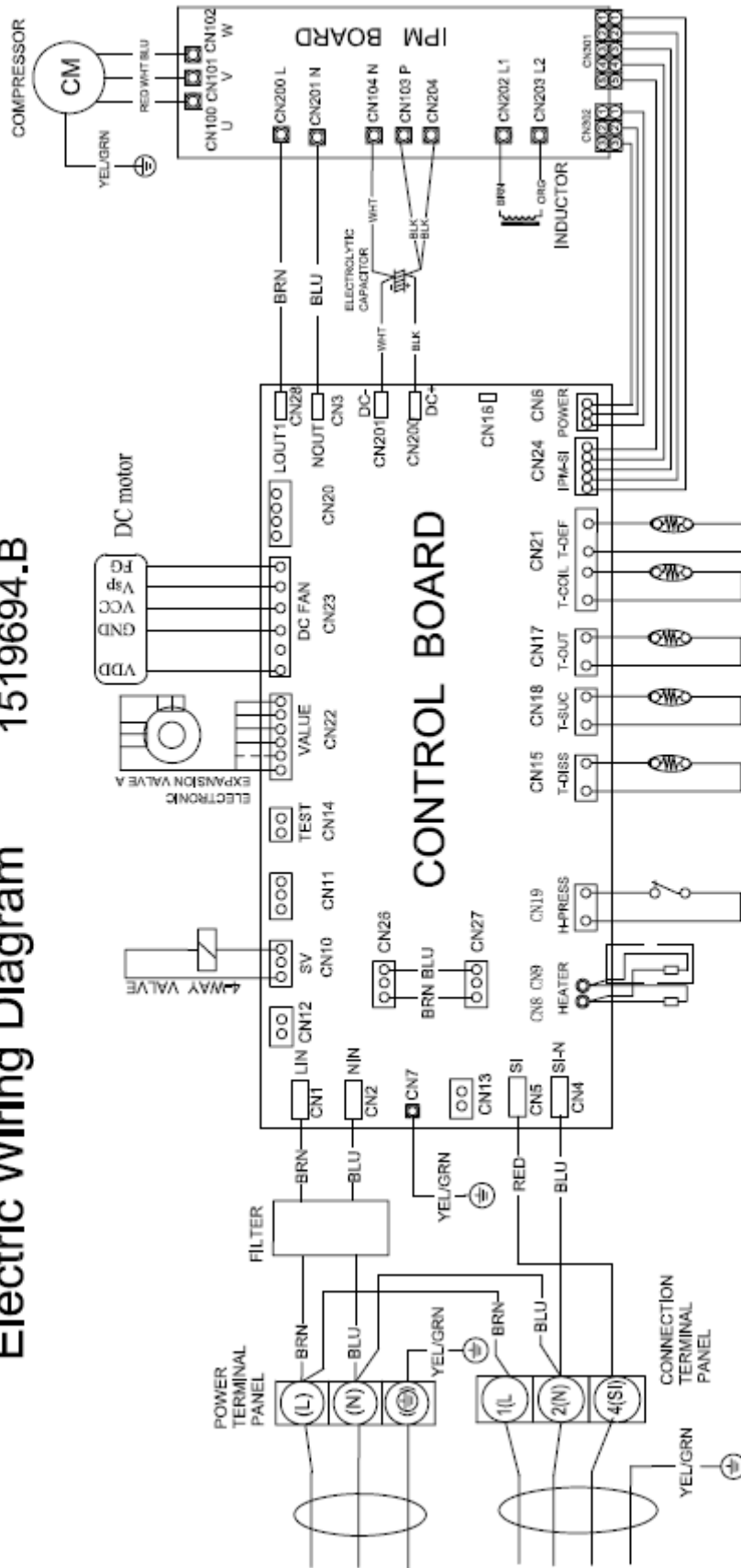

5. ELECTRICAL DATA

AUW-48U6SP

AUW-60U6SP

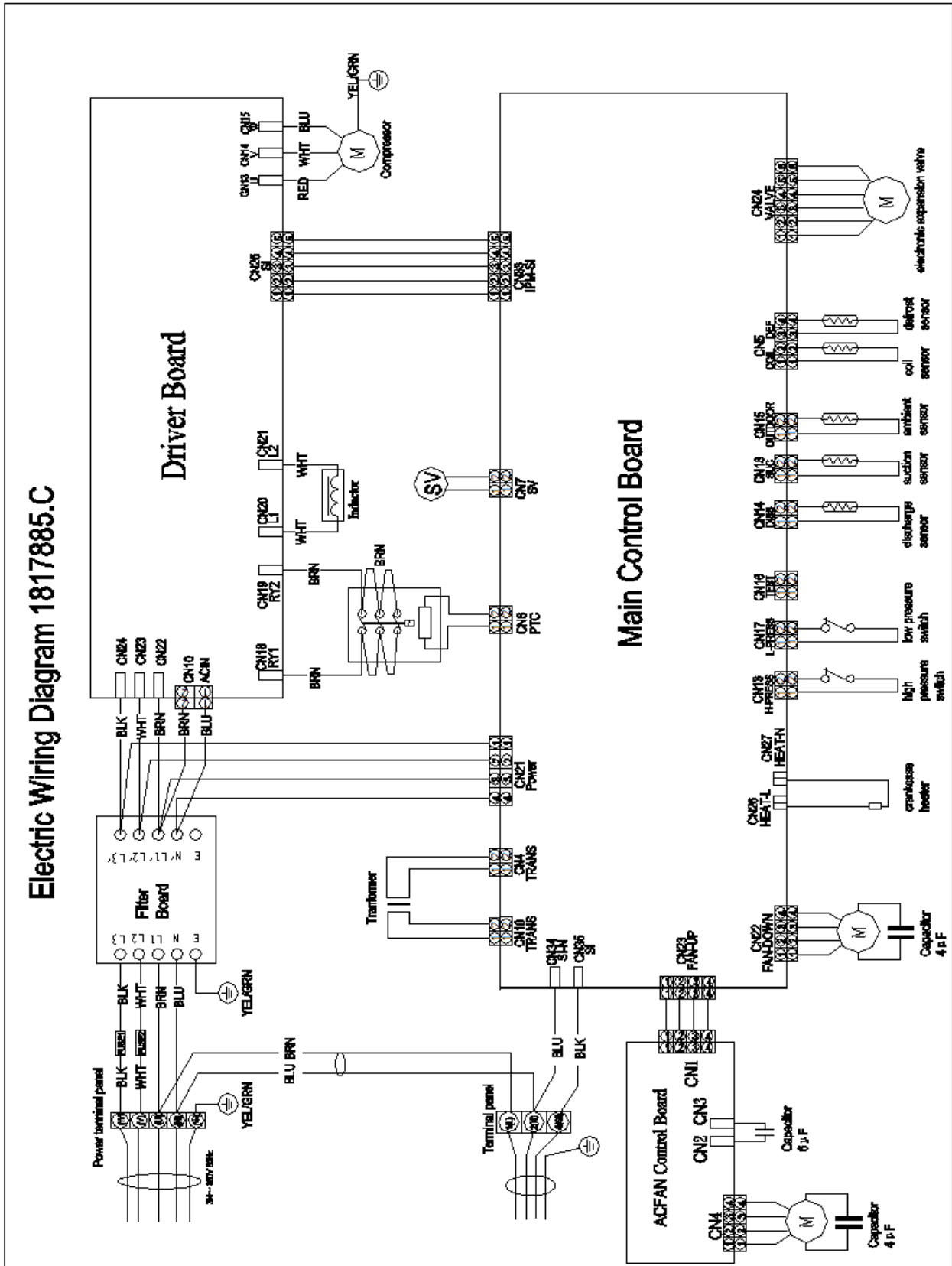

5. ELECTRICAL DATA

5-2. Electric control Board

1. Indoor control board

Duct type

18K,48K,60K

&AUD-24UX4SLH, AUD-36UX4SMH

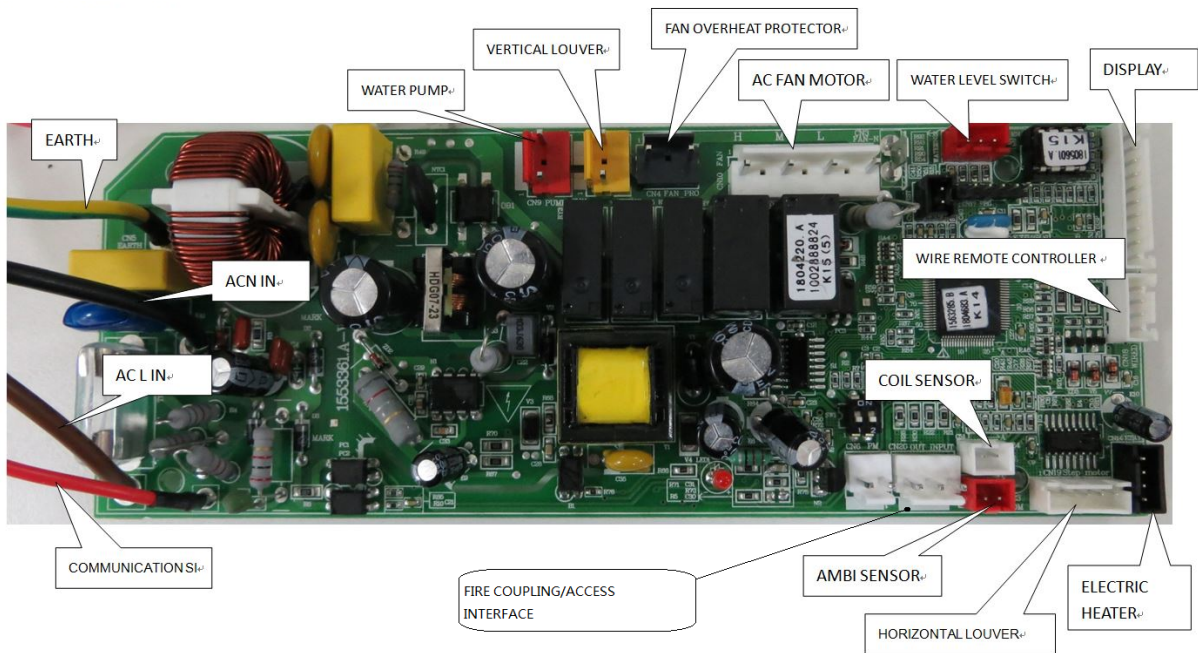

AUD-24UX4SLH1, AUD-36UX4SMH1

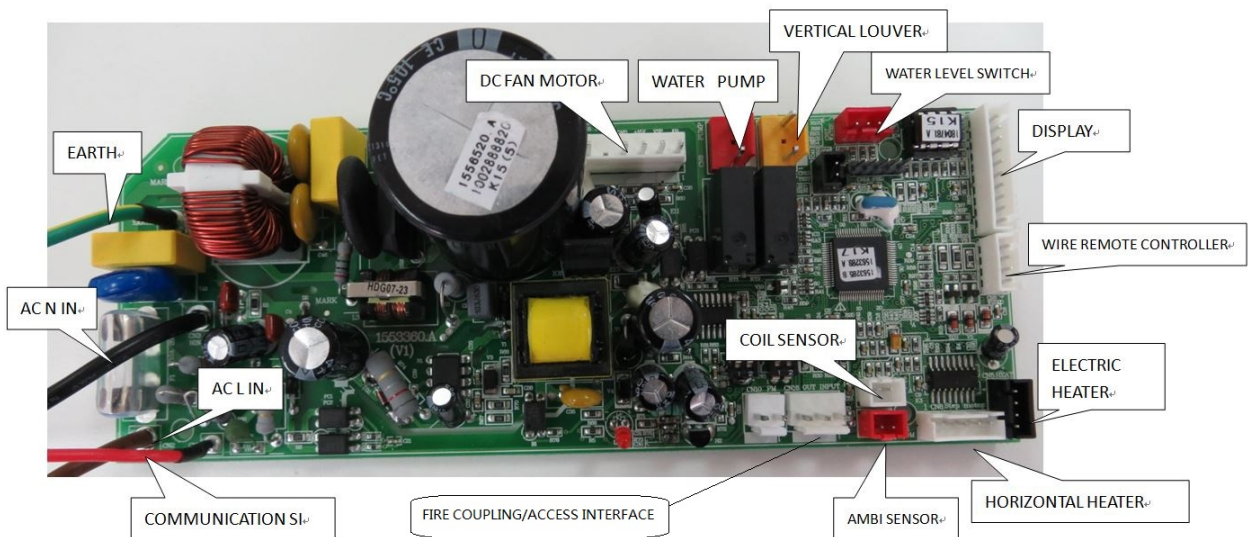

5. ELECTRICAL DATA

CASSETTE Type

18K

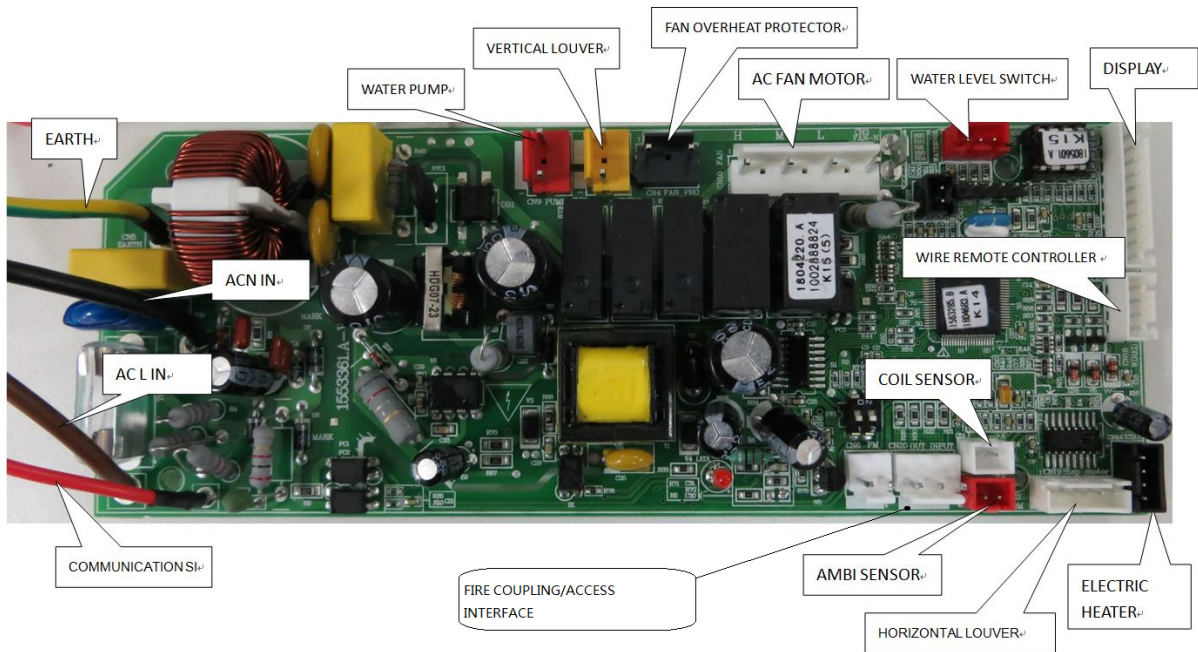

24K,36K,48K,60K

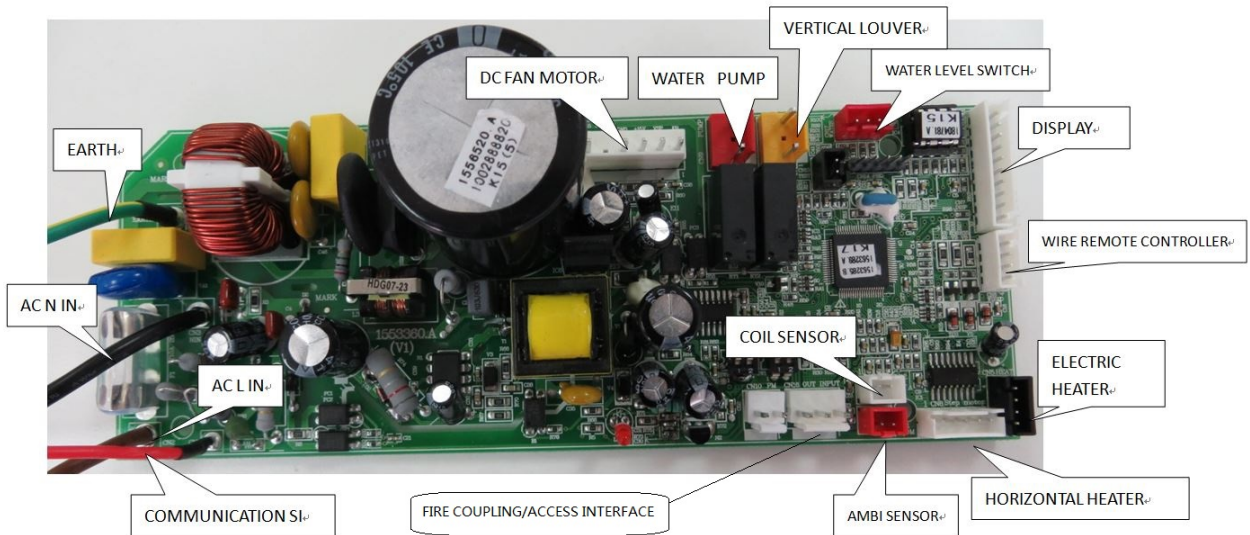

5. ELECTRICAL DATA

Ceiling & Floor type

18k,48k,60k

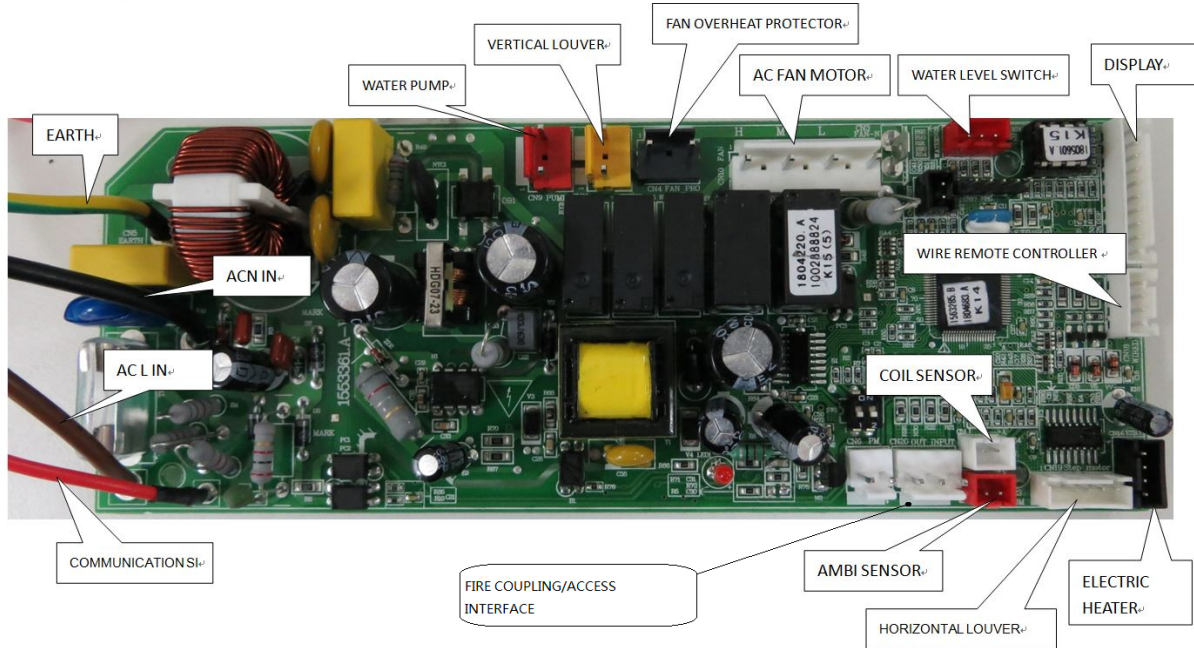

24k,36k

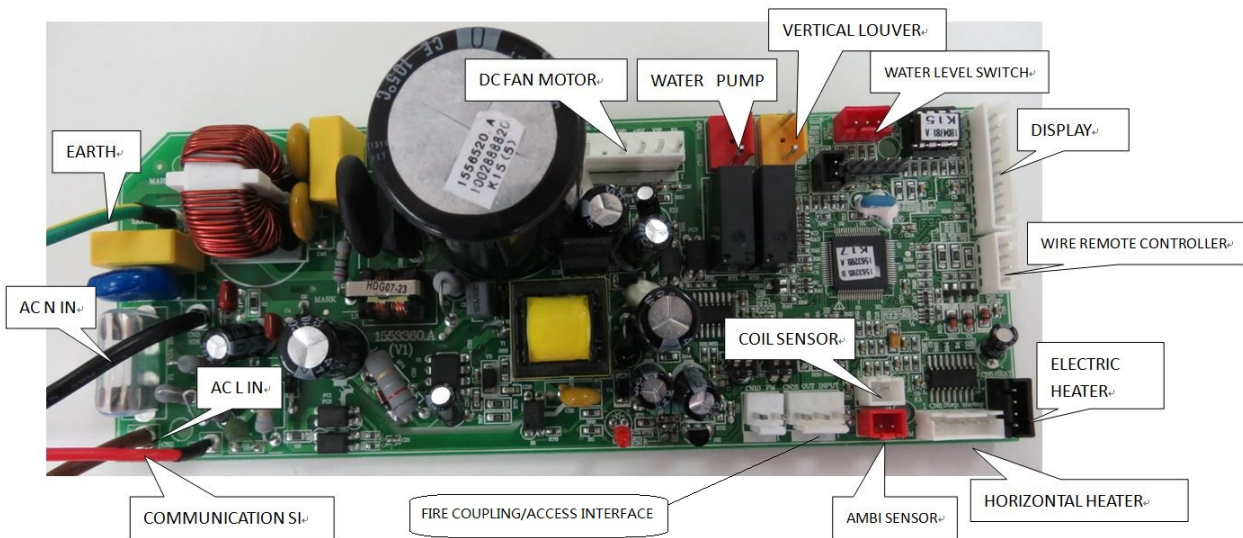

5. ELECTRICAL DATA

2. Control board for outdoor unit

1) OUTDOOR CONTROL BOARD

AUW-18U4SG

1) CONTROL BOARD (AUW-18U4SG)

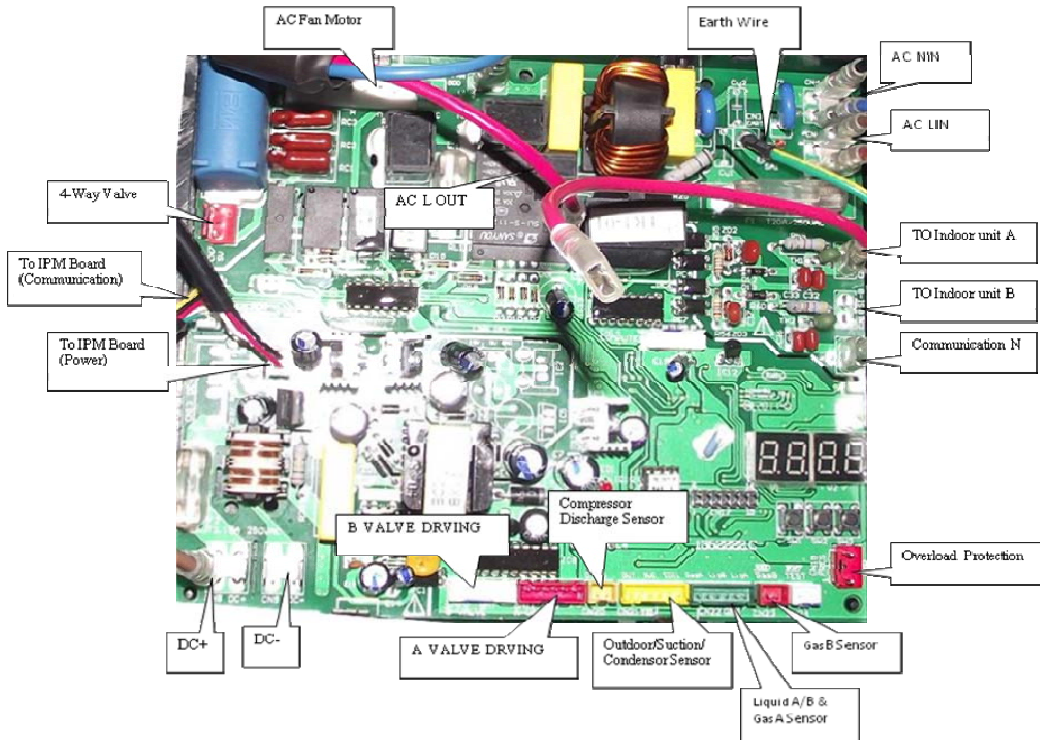

CONTROL BOARD (AUW-24U4SZ)

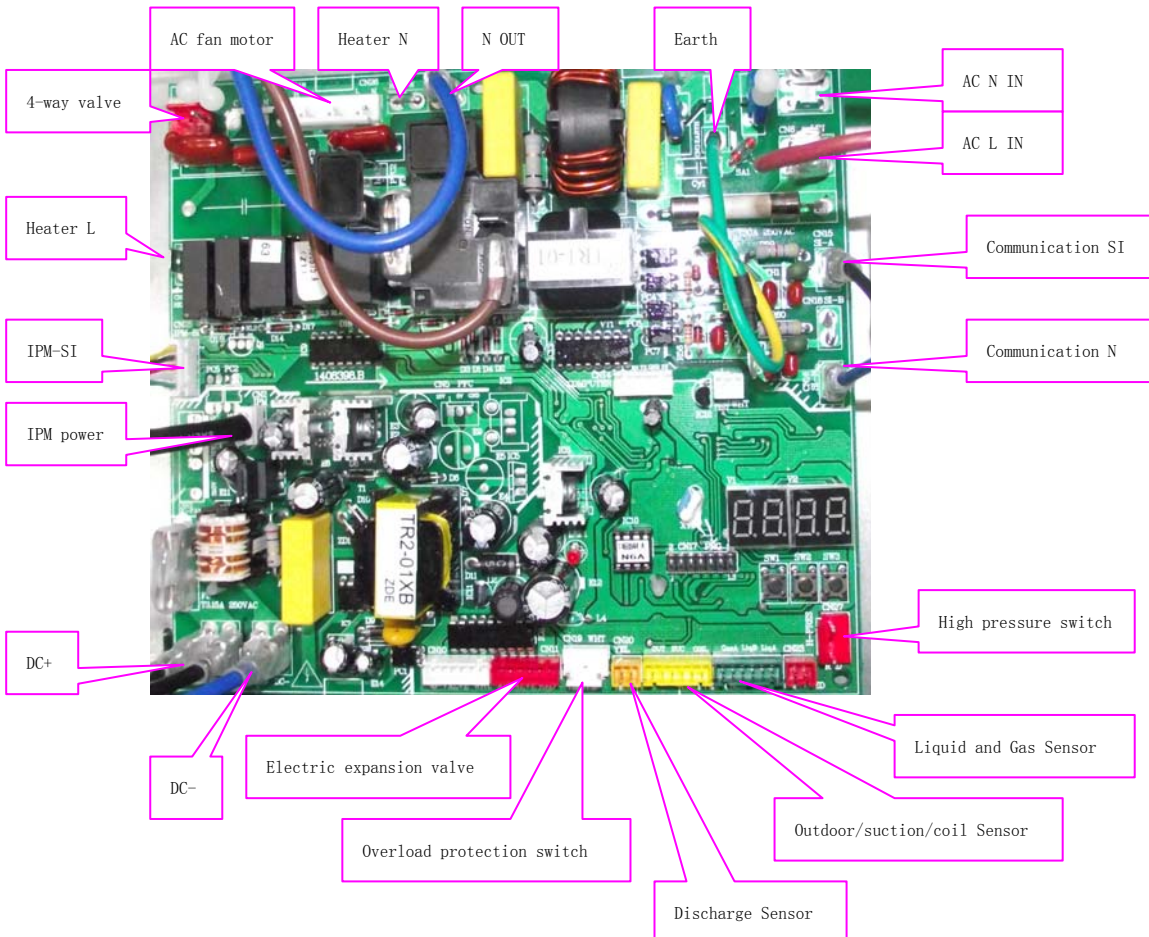

5. ELECTRICAL DATA

CONTROL BOARD (AUW-36U4SA)

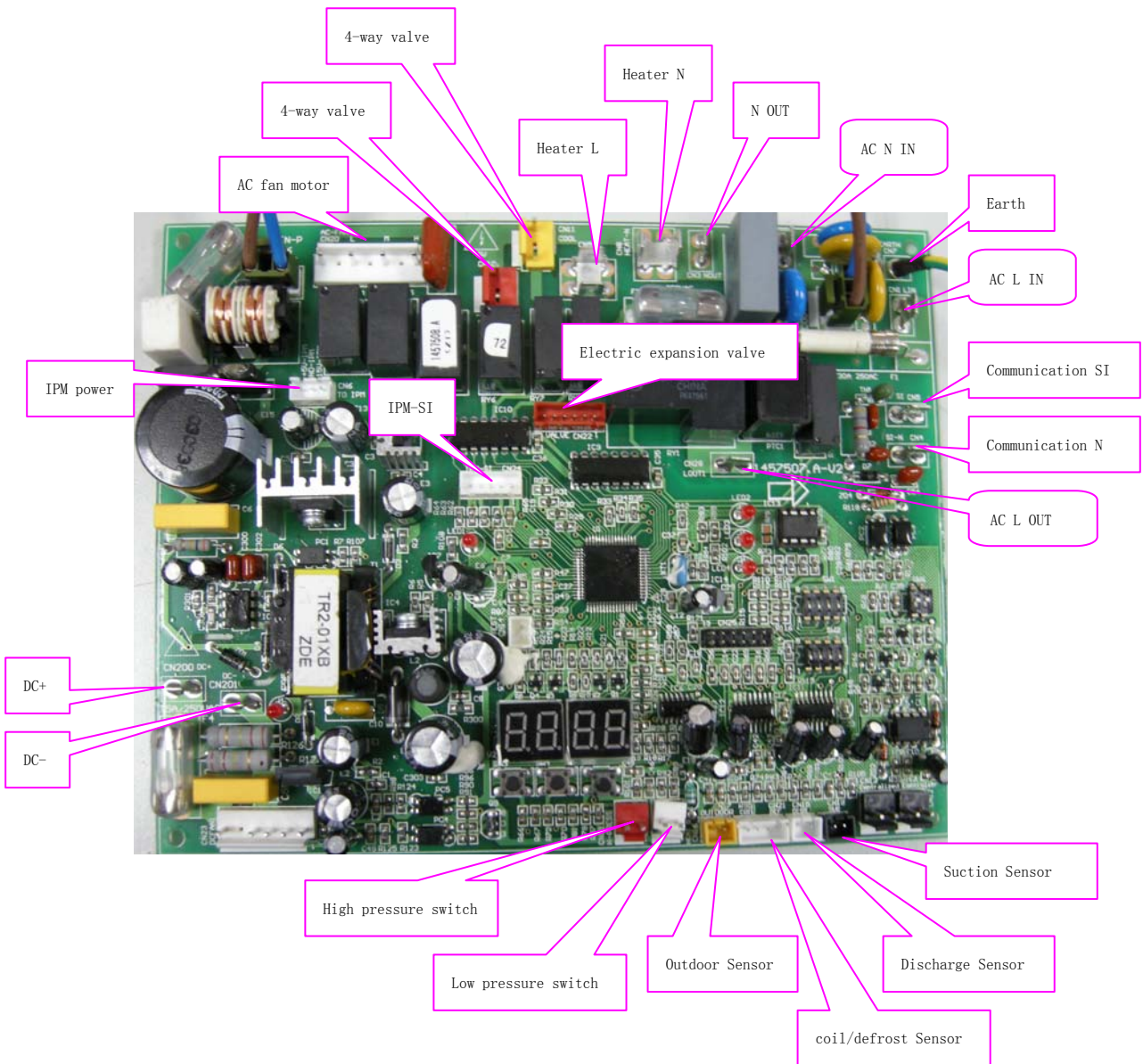

5. ELECTRICAL DATA

CONTROL BOARD (AUW-48U6SP, A UW-60U6SP)

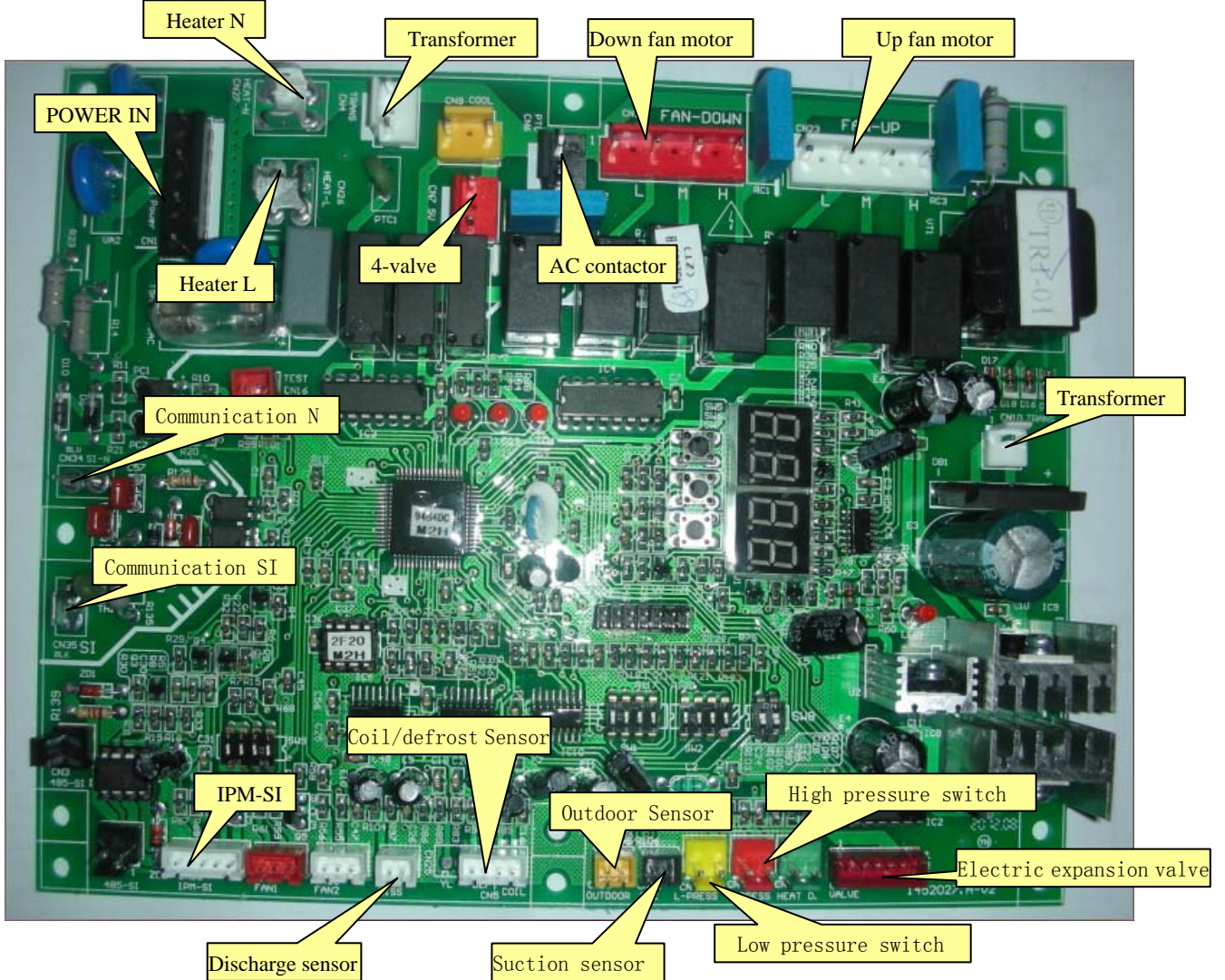

5. ELECTRICAL DATA

(AUW-18U4SZ1, AUW-24U4SA1, AUW-36U4SA1)

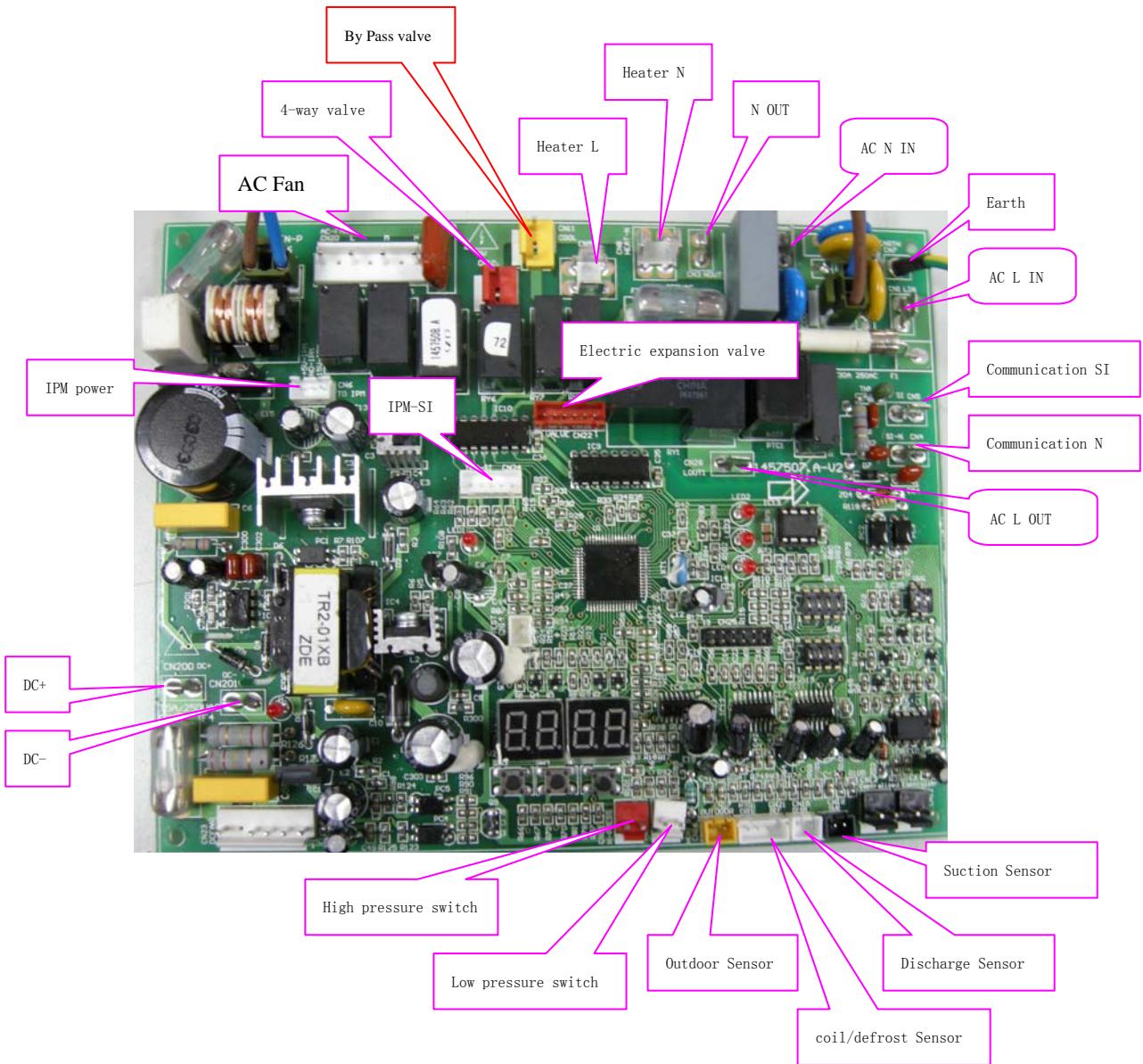

5. ELECTRICAL DATA

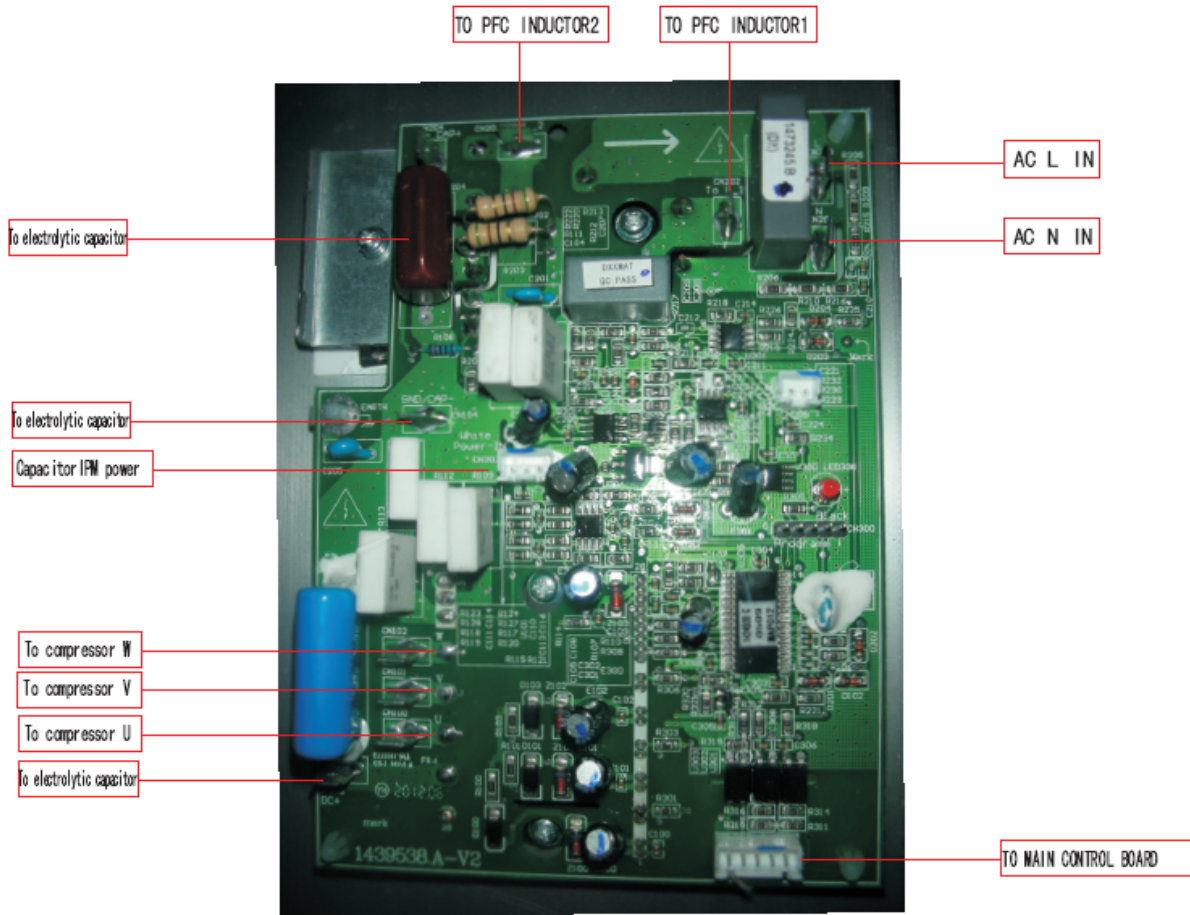

(AUW-48U6SP, AUW-60U6SP)

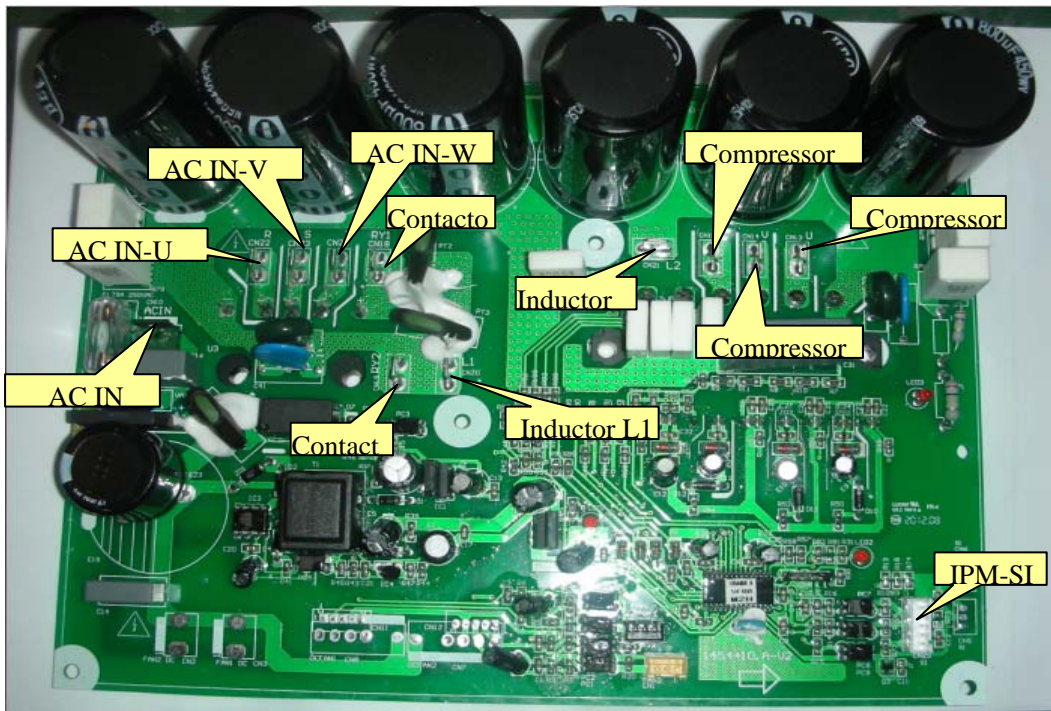

5. ELECTRICAL DATA

5-3. DIP SWITCH SETTING OF OUTDOOR

AUW-18U4SZ1,AUW-24U4SA1,AUW-36U4SA1,AUW-36W4SA

Dip Switch Setting of Outdoor Unit 1469538 .A

TURN OFF all power sources before setting.
Without turning OFF, the switches do not work
and the contents of the setting are invalid.
Mark of "■" indicates the position of dip switches.

SW1	Ref. Cycle No.Setting	SW2	Refrigerant Piping Length Setting				
<p>Setting is required</p> <p>Unit No.0 and No.1 setting condition Set the unit of outdoor unit at each refrigerant cycle. (setting before shipment is unit 0.)</p> <p>No.0</p> <p>ON <input type="checkbox"/> <input type="checkbox"/> <input type="checkbox"/> <input type="checkbox"/> OFF <input checked="" type="checkbox"/> <input checked="" type="checkbox"/> <input checked="" type="checkbox"/> <input checked="" type="checkbox"/> 1 2 3 4</p> <p>No.1</p> <p>ON <input type="checkbox"/> <input type="checkbox"/> <input type="checkbox"/> <input checked="" type="checkbox"/> OFF <input checked="" type="checkbox"/> <input checked="" type="checkbox"/> <input checked="" type="checkbox"/> <input checked="" type="checkbox"/> 1 2 3 4</p>		<p>Setting is required</p> <p>Actual Piping Length L(m)</p> <table border="1"> <thead> <tr> <th>L<15</th> <th>15≤L<30</th> </tr> </thead> <tbody> <tr> <td> <p>Setting before Shipment</p> <p>ON <input type="checkbox"/> <input type="checkbox"/> <input type="checkbox"/> <input type="checkbox"/> OFF <input checked="" type="checkbox"/> <input checked="" type="checkbox"/> <input checked="" type="checkbox"/> <input checked="" type="checkbox"/> 1 2 3 4</p> </td> <td> <p>ON <input checked="" type="checkbox"/> <input type="checkbox"/> <input type="checkbox"/> <input type="checkbox"/> OFF <input type="checkbox"/> <input type="checkbox"/> <input type="checkbox"/> <input type="checkbox"/> 1 2 3 4</p> </td> </tr> </tbody> </table>		L<15	15≤L<30	<p>Setting before Shipment</p> <p>ON <input type="checkbox"/> <input type="checkbox"/> <input type="checkbox"/> <input type="checkbox"/> OFF <input checked="" type="checkbox"/> <input checked="" type="checkbox"/> <input checked="" type="checkbox"/> <input checked="" type="checkbox"/> 1 2 3 4</p>	<p>ON <input checked="" type="checkbox"/> <input type="checkbox"/> <input type="checkbox"/> <input type="checkbox"/> OFF <input type="checkbox"/> <input type="checkbox"/> <input type="checkbox"/> <input type="checkbox"/> 1 2 3 4</p>
L<15	15≤L<30						
<p>Setting before Shipment</p> <p>ON <input type="checkbox"/> <input type="checkbox"/> <input type="checkbox"/> <input type="checkbox"/> OFF <input checked="" type="checkbox"/> <input checked="" type="checkbox"/> <input checked="" type="checkbox"/> <input checked="" type="checkbox"/> 1 2 3 4</p>	<p>ON <input checked="" type="checkbox"/> <input type="checkbox"/> <input type="checkbox"/> <input type="checkbox"/> OFF <input type="checkbox"/> <input type="checkbox"/> <input type="checkbox"/> <input type="checkbox"/> 1 2 3 4</p>						

48K&60K

Dip Switch Setting of Outdoor Unit

Turn off all power sources before setting.
Without turning off, the switches do not work
and the contents of the setting are invalid.
Mark of "■" indicates the position of dip switches.

SW1	Ref. Cycle No.Setting	SW2	Refrigerant Piping Length Setting				
<p>Setting is required</p> <p>Unit No.0 and No.1 setting condition Set the unit of outdoor unit at each refrigerant cycle. (setting before shipment is unit 0.)</p> <p>No.0</p> <p>ON <input type="checkbox"/> <input type="checkbox"/> <input type="checkbox"/> <input type="checkbox"/> OFF <input checked="" type="checkbox"/> <input checked="" type="checkbox"/> <input checked="" type="checkbox"/> <input checked="" type="checkbox"/> 1 2 3 4</p> <p>No.1</p> <p>ON <input type="checkbox"/> <input type="checkbox"/> <input type="checkbox"/> <input checked="" type="checkbox"/> OFF <input checked="" type="checkbox"/> <input checked="" type="checkbox"/> <input checked="" type="checkbox"/> <input checked="" type="checkbox"/> 1 2 3 4</p>		<p>Setting is required</p> <p>Actual Piping Length L(m)</p> <table border="1"> <thead> <tr> <th>L<15</th> <th>15≤L<30</th> </tr> </thead> <tbody> <tr> <td> <p>Setting before Shipment</p> <p>ON <input type="checkbox"/> <input type="checkbox"/> <input type="checkbox"/> <input type="checkbox"/> OFF <input checked="" type="checkbox"/> <input checked="" type="checkbox"/> <input checked="" type="checkbox"/> <input checked="" type="checkbox"/> 1 2 3 4</p> </td> <td> <p>ON <input checked="" type="checkbox"/> <input type="checkbox"/> <input type="checkbox"/> <input type="checkbox"/> OFF <input type="checkbox"/> <input type="checkbox"/> <input type="checkbox"/> <input type="checkbox"/> 1 2 3 4</p> </td> </tr> </tbody> </table>		L<15	15≤L<30	<p>Setting before Shipment</p> <p>ON <input type="checkbox"/> <input type="checkbox"/> <input type="checkbox"/> <input type="checkbox"/> OFF <input checked="" type="checkbox"/> <input checked="" type="checkbox"/> <input checked="" type="checkbox"/> <input checked="" type="checkbox"/> 1 2 3 4</p>	<p>ON <input checked="" type="checkbox"/> <input type="checkbox"/> <input type="checkbox"/> <input type="checkbox"/> OFF <input type="checkbox"/> <input type="checkbox"/> <input type="checkbox"/> <input type="checkbox"/> 1 2 3 4</p>
L<15	15≤L<30						
<p>Setting before Shipment</p> <p>ON <input type="checkbox"/> <input type="checkbox"/> <input type="checkbox"/> <input type="checkbox"/> OFF <input checked="" type="checkbox"/> <input checked="" type="checkbox"/> <input checked="" type="checkbox"/> <input checked="" type="checkbox"/> 1 2 3 4</p>	<p>ON <input checked="" type="checkbox"/> <input type="checkbox"/> <input type="checkbox"/> <input type="checkbox"/> OFF <input type="checkbox"/> <input type="checkbox"/> <input type="checkbox"/> <input type="checkbox"/> 1 2 3 4</p>						
<p>SW9 Transmission Setting</p> <p>Setting is required</p> <table border="1"> <thead> <tr> <th>Setting before Shipment</th> <th>When using end resistance and bias resistor</th> </tr> </thead> <tbody> <tr> <td> <p>ON <input type="checkbox"/> <input type="checkbox"/> <input type="checkbox"/> <input type="checkbox"/> OFF <input checked="" type="checkbox"/> <input checked="" type="checkbox"/> <input checked="" type="checkbox"/> <input checked="" type="checkbox"/> 1 2 3 4</p> </td> <td> <p>ON <input checked="" type="checkbox"/> <input checked="" type="checkbox"/> <input checked="" type="checkbox"/> <input checked="" type="checkbox"/> OFF <input type="checkbox"/> <input type="checkbox"/> <input type="checkbox"/> <input type="checkbox"/> 1 2 3 4</p> </td> </tr> </tbody> </table>				Setting before Shipment	When using end resistance and bias resistor	<p>ON <input type="checkbox"/> <input type="checkbox"/> <input type="checkbox"/> <input type="checkbox"/> OFF <input checked="" type="checkbox"/> <input checked="" type="checkbox"/> <input checked="" type="checkbox"/> <input checked="" type="checkbox"/> 1 2 3 4</p>	<p>ON <input checked="" type="checkbox"/> <input checked="" type="checkbox"/> <input checked="" type="checkbox"/> <input checked="" type="checkbox"/> OFF <input type="checkbox"/> <input type="checkbox"/> <input type="checkbox"/> <input type="checkbox"/> 1 2 3 4</p>
Setting before Shipment	When using end resistance and bias resistor						
<p>ON <input type="checkbox"/> <input type="checkbox"/> <input type="checkbox"/> <input type="checkbox"/> OFF <input checked="" type="checkbox"/> <input checked="" type="checkbox"/> <input checked="" type="checkbox"/> <input checked="" type="checkbox"/> 1 2 3 4</p>	<p>ON <input checked="" type="checkbox"/> <input checked="" type="checkbox"/> <input checked="" type="checkbox"/> <input checked="" type="checkbox"/> OFF <input type="checkbox"/> <input type="checkbox"/> <input type="checkbox"/> <input type="checkbox"/> 1 2 3 4</p>						

5. ELECTRICAL DATA

5-4. Digital Display Switch of Outdoor

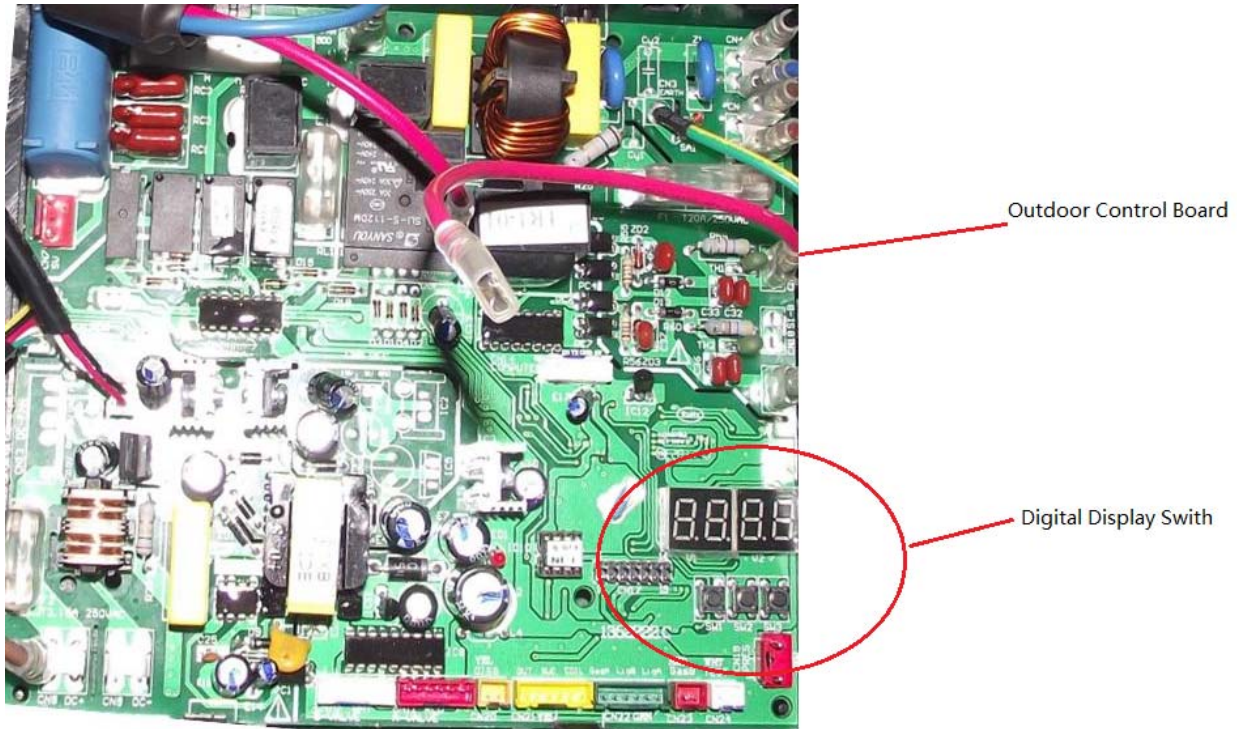

Digital Display Switch Introduction

It can be used to check outdoor running parameters.

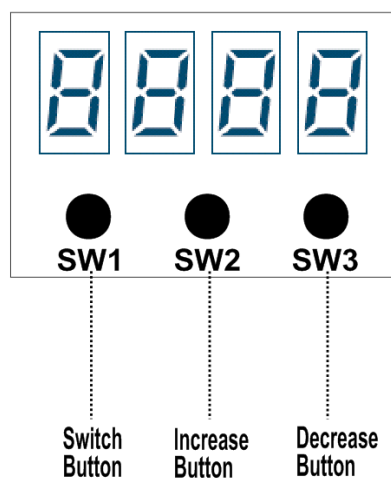

There are 3 buttons on the digital display board :

1) SWITCH button : Indoor parameters and outdoor parameters can be selected in turn by pressing it.

P--outdoor unit, H--indoor unit ;

2) INCREASE button : Each time it is pressed, the number rises by 1,hold down it, the number will be rapidly rises ;

3) DECREASE button : Each time it is pressed, the number lowers by 1,hold down it, the number will be rapidly lowers.

5. ELECTRICAL DATA

4) The parameters will be displayed after 3s when the checking numbers are selected.

Parameters can be checked as following table below.

Parameter code	Descriptions
0	Protect Code or Error Code
P.1	Target Frequency
P.2	Driver Frequency
P.4	Outdoor Electronic expansion valve Opening
P.5	Outdoor Electronic expansion valve Target Opening
P.6	Upper DC Motor Revolving Speed
P.8	AC Input Voltage
P.9	Current
P.10	Modular Temperature
P.11	Capacity needed
P.12	Modular Trouble
P.20	Outdoor Ambient Temperature
P.21	Outdoor Coil Temperature
P.22	Outdoor Defrost Temperature
P.23	Suction Temperature
P.24	Discharge Temperature
H.1	Indoor Unit Error
H.2	Indoor Ambient Temperature
H.3	Indoor Coil Temperature
H.4	Indoor Setting Temperature

5. ELECTRICAL DATA

5-5. Static Pressure Setting (only for duct type)

CHANGE OF STATIC PRESSURE

The static pressure outside the indoor unit can be chosen .

Models except DC FAN MOTERS(AUD-24UX4SALH1 & AUD-36UX4SAMH1) :

You can change the static pressure by changing the fan motor terminal which refer to following Fig.below:

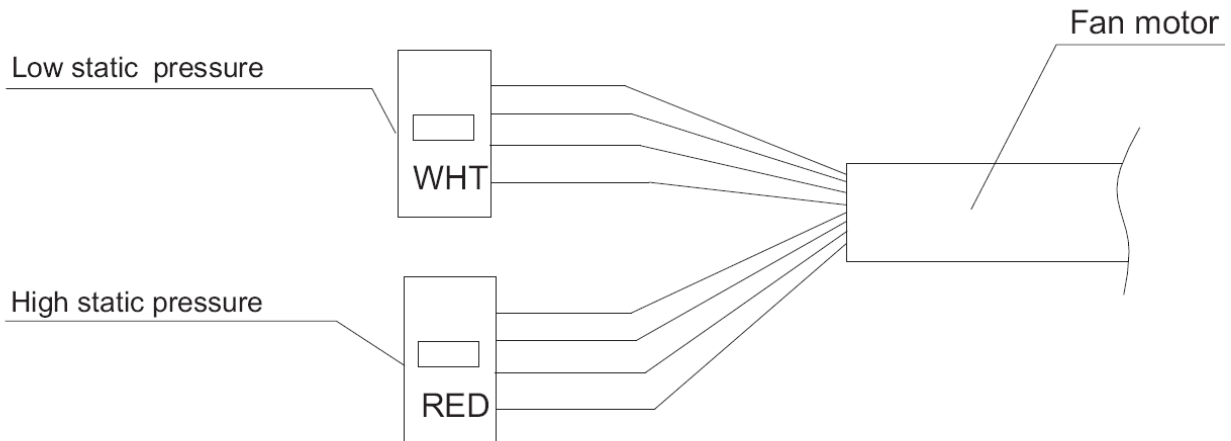

Model	Low static pressure	High static pressure
18K	10Pa	30Pa
24K, 36K	50Pa	80Pa
48K, 60K	80Pa	120Pa

Note: Default Settings is low static pressure by factory.

The noise under high static pressure is higher than static pressure .

FOR DC FAN MOTER DUCT AIR CONDITIONERS(AUD-24UX4SALH1 & AUD-36UX4SAMH1) :

Default static pressure is 30 Pa.

The static pressure can be freely adjusted from 1 Pa to 80 Pa by using specific wire remote controller(YXE-C01U/YXE-C02U).

Operation details, please refer to **5.6 System Parameter Adjustment** .

If you still have any trouble, please contact local technical service center of our company for further information.

5. ELECTRICAL DATA

5-6 System Parameter Adjustment

Internal control parameter adjustment can be performed.

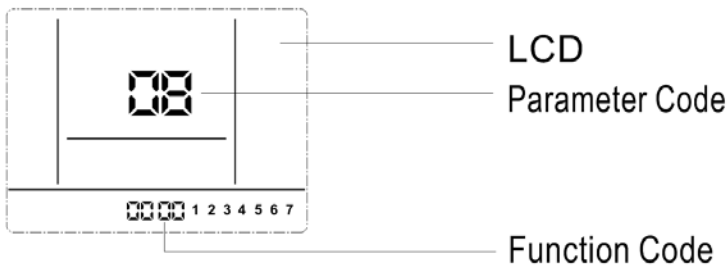

OPERATION:

① Hold down both "MODE" button and "ADD.FUNC." button for 3 seconds, symbol  and parameter number blinking at the same time.

② Press "▲" "▼" button to adjust parameter number until display "17".

And press "ENTER" button to entering system parameter adaption state, symbol  stop blinking.

③ Select desired parameter code by pressing ▲/ ▼ button following the table below.

Press the "ENTER" button to rewrite the parameter values using "▲/ ▼" buttons .

PARAMETER CODE	PARAMETER DESCRIPTION	PARAMETER VALUE&REPRESENTATION		NOTE
		DATA TYPE	REPRESENTATION(FUNCTION CODE)	
1	Self Recovery of Power Break	Integer	0: Cancel Self Recovery of Power Break function; 1: Self Recovery of Power Break; others: invalid	
2	Temperature Type	Integer	0: Centigrade Temperature; 1: Fahrenheit Temperature; others: invalid	
3	Temperature Display Type	Integer	0: Default display set temperature; 1: Default display room temperature; others: invalid	
4	Ratio of temperature sensed by Wire remote controller(cooling mode)	Integer	0-10valid, more than 10 default is10 0: 0%; 1: 10%; ...; 10: 100%	
5	Filter Clean Indicate	Integer	0: Cancel Filter Clean Indicate function; 1: Set Filter Clean Indicate function; others: invalid	
6	Filter Clean Time Set	Integer	0-32, more than 32 default is 32*1000h	
7	Installation Height	Integer	0-10m, more than 10m default is 10	
8	Cooling Temperature Compensation (wired controller)	Integer	0: 0°C; 1: -0.5°C; 2: -1°C; 3: -1.5°C; 4: -2°C; 5: -2.5°C; 6: -3°C; 7: -3.5°C; 8: -4°C; 9: -4.5°C; 10: -5°C; (the wired controller displays integer with the symbol)	
9	Heating Temperature Compensation (wired controller)	Integer	0: 0°C; 1: -0.5°C; 2: -1°C; 3: -1.5°C; 4: -2°C; 5: -2.5°C; 6: -3°C; 7: -3.5°C; 8: -4°C; 9: -4.5°C; 10: -5°C; (the wired controller displays integer with the symbol)	
10	Static Pressure Set	Integer	1-80, more than 80 default is 80, Default is 0(30Pa)	only valid for 24k/36K DC MOTOR TYPE
12	Ratio of temperature sensed by Wire remote controller(Heating mode)	Integer	0-10valid, more than 10 default is10 0: 0%; 1: 10%; ...; 10: 100%	
13	Temperature Adjustment-Cooling	Character	-10-10°C (Single Character with symbol)	

5. ELECTRICAL DATA

PARAMETER CODE	PARAMETER DESCRIPTION	PARAMETER VALUE&REPRESENTATION		NOTE
		DATA TYPE	REPRESENTATION(FUNCTION CODE)	
14	Temperature Adjustment-Heating	Character	-10-10℃ (Single Character with symbol)	
18	Cooling/Heating Temperature Limit	Integer	=0, Cooling/Heating Temperature Limit are all Invalid	
			=1, Cooling Temperature Limit is valid, Heating Temperature Limit is invalid	
			=2, Cooling Temperature Limit is invalid, Heating Temperature Limit is valid	
			=3, Cooling/Heating Temperature Limit are all valid	
19	The Lowest Set Temperature in Cooling Mode	Integer	SET VALUE=Actual temperature (16℃-32℃)	
20	The Highest Set Temperature in Heating Mode	Integer	SET VALUE=Actual temperature (16℃-32℃)	



Parameter code will not display if the indoor unit is not equipped with this function. Please refer to indoor unit manual to check whether this function is effective.

EXIT :

Press "ON/OFF" button to exit, or no operation within 30 seconds automatically exit.

5. ELECTRICAL DATA

5-7. Sensor parameter

1. THE PARAMETER OF OUTDOOR COMPRESSOR DISCHARGE TEMPERATURE SENSOR:

($R_0=187.25K \pm 6.3\%$; $R_{100}=3.77K \pm 2.5K$; $B_0/100=3979K \pm 1\%$)

T [°C]	Rmin [K Ω]	Rnom [K Ω]	Rmax [K Ω]	DR(MIN)%	DR(MAX)%
-30	908.2603	985.5274	1065.1210	-7.84	7.47
-29	855.3955	927.6043	1001.9150	-7.78	7.42
-28	805.9244	873.4324	924.8368	-7.73	5.56
-27	759.6097	822.7471	887.5944	-7.67	7.31
-26	716.2320	775.3041	835.9165	-7.62	7.25
-25	675.5881	730.8775	787.5529	-7.56	7.20
-24	637.4902	689.2583	742.2720	-7.51	7.14
-23	601.7645	650.2533	699.8601	-7.46	7.09
-22	568.2499	613.6835	660.1191	-7.40	7.03
-21	536.7970	579.3832	622.8658	-7.35	6.98
-20	507.2676	547.1989	587.9307	-7.30	6.93
-19	497.5332	516.9882	555.1565	-3.76	6.88
-18	453.4748	488.6192	524.3977	-7.19	6.82
-17	428.9819	461.9693	495.5191	-7.14	6.77
-16	405.9517	436.9251	486.3954	-7.09	10.17
-15	384.2888	413.3808	442.9105	-7.04	6.67
-14	363.9047	391.2386	418.9563	-6.99	6.62
-13	344.7169	370.4072	396.4325	-6.94	6.56
-12	326.6497	350.8019	375.2461	-6.88	6.51
-11	309.6286	332.3441	355.3104	-6.83	6.46
-10	293.5903	314.9620	336.5448	-6.79	6.41
-9	278.4719	298.5822	318.3744	-6.74	6.22
-8	264.2156	283.1464	302.2294	-6.69	6.31
-7	250.7678	268.5936	286.5448	-6.64	6.26
-6	238.0783	254.8686	271.7603	-6.59	6.22
-5	226.1003	241.9200	257.8193	-6.54	6.17
-4	214.7903	229.6997	244.6593	-6.49	6.11
-3	204.1073	218.1630	232.2612	-6.44	6.07
-2	194.0135	207.2681	220.5495	-6.39	6.02
-1	184.4732	196.9759	209.4913	-6.35	5.97
0	175.4533	187.2500	199.0468	-6.30	5.93
1	166.8952	178.0255	189.1529	-6.25	5.88
2	158.8023	169.3067	179.8058	-6.20	5.84
3	151.1467	161.0633	170.9724	-6.16	5.80
4	143.9026	153.2667	162.6216	-6.11	5.75
5	137.0455	145.8905	154.7246	-6.06	5.71
6	130.5528	138.9097	147.2544	-6.02	5.67
7	124.4033	132.3011	140.1856	-5.97	5.62
8	118.5769	126.0429	133.4946	-5.92	5.58
9	113.0550	120.1146	127.1591	-5.88	5.54

5. ELECTRICAL DATA

T [°C]	Rmin [K Ω]	Rnom [K Ω]	Rmax [K Ω]	DR(MIN)%	DR(MAX)%
10	107.8202	114.4973	121.1586	-5.83	5.50
11	102.8560	109.1728	115.4734	-5.79	5.46
12	98.1470	104.1246	110.0855	-5.74	5.41
13	93.6787	99.3367	104.9778	-5.70	5.37
14	89.4378	94.7946	100.1342	-5.65	5.33
15	85.4114	90.4842	95.5398	-5.61	5.29
16	81.5875	86.3926	91.1805	-5.56	5.25
17	77.9551	82.5076	87.0430	-5.52	5.21
18	74.5034	78.8177	83.1150	-5.47	5.17
19	71.2227	75.3122	79.3848	-5.43	5.13
20	68.1036	71.9808	75.8414	-5.39	5.09
21	65.1373	68.8141	72.4746	-5.34	5.05
22	62.3155	65.8032	69.2746	-5.30	5.01
23	59.6306	62.9395	66.2324	-5.26	4.97
24	57.0752	60.2152	63.3395	-5.21	4.93
25	54.6424	57.6227	60.5877	-5.17	4.89
26	52.3258	55.1551	57.9695	-5.13	4.85
27	50.1192	52.8058	55.4778	-5.09	4.82
28	48.0168	50.5684	53.1058	-5.05	4.78
29	46.0133	48.4371	50.8472	-5.00	4.74
30	44.1034	46.4046	48.6960	-4.96	4.71
31	42.2825	44.4711	46.6466	-4.92	4.66
32	40.5458	42.6261	44.6937	-4.88	4.63
33	38.8891	40.8668	42.8323	-4.84	4.59
34	37.3084	39.1890	41.0576	-4.80	4.55
35	35.7998	37.5883	39.3653	-4.76	4.51
36	34.3596	36.0609	37.7511	-4.72	4.48
37	32.9844	34.6030	36.2109	-4.68	4.44
38	31.6710	33.2113	34.7412	-4.64	4.40
39	30.4164	31.8823	33.3383	-4.60	4.37
40	29.2176	30.6130	31.9988	-4.56	4.33
41	28.0718	29.4004	30.7197	-4.52	4.29
42	26.9765	28.2417	29.4979	-4.48	4.26
43	25.9293	27.1342	28.3306	-4.44	4.22
44	24.9277	26.0755	27.2150	-4.40	4.19
45	23.9697	25.0632	26.1488	-4.36	4.15
46	23.0530	24.0950	25.1293	-4.32	4.12
47	22.1757	23.1688	24.1545	-4.29	4.08
48	21.3360	22.2826	23.2221	-4.25	4.05
49	20.5321	21.4345	22.3301	-4.21	4.01
50	19.7623	20.6226	21.4766	-4.17	3.98
51	19.0261	19.8468	20.6612	-4.14	3.94
52	18.3211	19.1040	19.8808	-4.10	3.91

5. ELECTRICAL DATA

T [°C]	Rmin [K Ω]	Rnom [K Ω]	Rmax [K Ω]	DR(MIN)%	DR(MAX)%
53	17.6458	18.3926	19.1338	-4.06	3.87
54	16.9986	17.7113	18.4185	-4.02	3.84
55	16.3784	17.0537	17.7335	-3.96	3.83
56	15.7839	16.4332	17.0774	-3.95	3.77
57	15.2139	15.8338	16.4488	-3.92	3.74
58	14.6673	15.2592	15.8464	-3.88	3.71
59	14.1430	14.7083	15.2690	-3.84	3.67
60	13.6400	14.1799	14.7154	-3.81	3.64
61	13.1573	13.6730	14.1846	-3.77	3.61
62	12.6941	13.1868	13.6756	-3.74	3.57
63	12.2494	12.7202	13.1872	-3.70	3.54
64	11.8224	12.2723	12.7186	-3.67	3.51
65	11.4124	11.8424	12.2690	-3.63	3.48
66	11.0185	11.4295	11.8373	-3.60	3.45
67	10.6401	11.0331	11.4230	-3.56	3.41
68	10.2765	10.6522	11.0251	-3.53	3.38
69	9.9271	10.2863	10.6429	-3.49	3.35
70	9.5912	9.9348	10.2756	-3.46	3.32
71	9.2682	9.5968	9.9231	-3.42	3.29
72	8.9576	9.2720	9.5841	-3.39	3.26
73	8.6589	8.9597	9.2583	-3.36	3.23
74	8.3716	8.6594	8.9451	-3.32	3.19
75	8.0951	8.3705	8.6440	-3.29	3.16
76	7.8290	8.0926	8.3544	-3.26	3.13
77	7.5730	7.8252	8.0758	-3.22	3.10
78	7.3264	7.5679	7.8078	-3.19	3.07
79	7.0891	7.3202	7.5499	-3.16	3.04
80	6.8605	7.0818	7.3018	-3.12	3.01
81	6.6403	6.8522	7.0629	-3.09	2.98
82	6.4282	6.6311	6.8329	-3.06	2.95
83	6.2239	6.4182	6.6115	-3.03	2.92
84	6.0269	6.2131	6.3982	-3.00	2.89
85	5.8371	6.0154	6.1928	-2.96	2.86
86	5.6542	5.8249	5.9949	-2.93	2.84
87	5.4777	5.6413	5.8042	-2.90	2.81
88	5.3076	5.4644	5.6205	-2.87	2.78
89	5.1435	5.2937	5.4433	-2.84	2.75
90	4.9853	5.1292	5.2726	-2.81	2.72
91	4.8326	4.9705	5.1079	-2.77	2.69
92	4.6852	4.8174	4.9492	-2.74	2.66
93	4.5430	4.6697	4.7960	-2.71	2.63
94	4.4058	4.5272	4.6483	-2.68	2.61
95	4.2733	4.3896	4.5058	-2.65	2.58

5. ELECTRICAL DATA

T [°C]	Rmin [K Ω]	Rnom [K Ω]	Rmax [K Ω]	DR(MIN)%	DR(MAX)%
96	4.1453	4.2568	4.3683	-2.62	2.55
97	4.0218	4.1287	4.2355	-2.59	2.52
98	3.9024	4.0049	4.1074	-2.56	2.50
99	3.7872	3.8854	3.9837	-2.53	2.47
100	3.6758	3.7700	3.8643	-2.50	2.44
101	3.5661	3.6585	3.7512	-2.53	2.47
102	3.4601	3.5509	3.6419	-2.56	2.50
103	3.3577	3.4468	3.5362	-2.59	2.53
104	3.2588	3.3463	3.4341	-2.61	2.56
105	3.1632	3.2491	3.3353	-2.64	2.58
106	3.0708	3.1551	3.2398	-2.67	2.61
107	2.9816	3.0643	3.1475	-2.70	2.64
108	2.8953	2.9765	3.0582	-2.73	2.67
109	2.8118	2.8915	2.9717	-2.76	2.70
110	2.7311	2.8093	2.8881	-2.78	2.73
111	2.6531	2.7299	2.8072	-2.81	2.75
112	2.5776	2.6530	2.7289	-2.84	2.78
113	2.5046	2.5785	2.6531	-2.87	2.81
114	2.4340	2.5065	2.5798	-2.89	2.84
115	2.3656	2.4368	2.5087	-2.92	2.87
116	2.2995	2.3693	2.4400	-2.95	2.90
117	2.2354	2.3040	2.3733	-2.98	2.92
118	2.1734	2.2407	2.3088	-3.00	2.95
119	2.1134	2.1795	2.2463	-3.03	2.97
120	2.0553	2.1201	2.1858	-3.06	3.01
121	1.9991	2.0626	2.1271	-3.08	3.03
122	1.9446	2.0070	2.0702	-3.11	3.05
123	1.8918	1.9530	2.0151	-3.13	3.08
124	1.8406	1.9007	1.9617	-3.16	3.11
125	1.7911	1.8500	1.9099	-3.18	3.14
126	1.7430	1.8009	1.8597	-3.22	3.16
127	1.6965	1.7533	1.8110	-3.24	3.19
128	1.6514	1.7071	1.7638	-3.26	3.21
129	1.6076	1.6623	1.7180	-3.29	3.24
130	1.5652	1.6189	1.6736	-3.32	3.27

5. ELECTRICAL DATA

2. THE PARAMETER OF THE OTHER SENSOR IN INDOOR AND OUTDOOR UNIT: ($R_0=15K \pm 2\%$;
 $B0/100=3450K \pm 2\%$)

T [°C]	Rmin [K Ω]	Rnom [K Ω]	Rmax [K Ω]	DR(MIN)%	DR(MAX)%
-30	60.78	64.77	68.99	-6.16	6.12
-29	57.75	61.36	65.16	-5.88	5.83
-28	54.89	58.15	61.58	-5.61	5.57
-27	52.19	55.14	58.23	-5.35	5.31
-26	49.63	52.30	55.08	-5.11	5.05
-25	47.21	49.62	52.13	-4.86	4.81
-24	44.92	47.10	49.37	-4.63	4.60
-23	42.76	44.73	46.78	-4.40	4.38
-22	40.71	42.49	44.34	-4.19	4.17
-21	38.77	40.38	42.05	-3.99	3.97
-20	36.93	38.39	39.90	-3.80	3.78
-19	35.18	36.51	37.87	-3.64	3.59
-18	33.53	34.74	35.97	-3.48	3.42
-17	31.96	33.06	34.17	-3.33	3.25
-16	30.48	31.47	32.49	-3.15	3.14
-15	29.07	29.97	30.89	-3.00	2.98
-14	27.73	28.56	29.39	-2.91	2.82
-13	26.46	27.22	27.98	-2.79	2.72
-12	25.26	25.95	26.64	-2.66	2.59
-11	24.11	24.75	25.38	-2.59	2.48
-10	23.03	23.61	24.19	-2.46	2.40
-9	21.99	22.53	23.06	-2.40	2.30
-8	21.01	21.51	22.00	-2.32	2.23
-7	20.08	20.54	20.99	-2.24	2.14
-6	19.19	19.62	20.04	-2.19	2.10
-5	18.35	18.74	19.14	-2.08	2.09
-4	17.55	17.92	18.29	-2.06	2.02
-3	16.78	17.13	17.48	-2.04	2.00
-2	16.06	16.38	16.71	-1.95	1.97
-1	15.36	15.67	15.98	-1.98	1.94
0	14.70	15.00	15.29	-2.00	1.90
1	14.08	14.36	14.64	-1.95	1.91
2	13.48	13.75	14.02	-1.96	1.93
3	12.91	13.17	13.43	-1.97	1.94
4	12.36	12.62	12.87	-2.06	1.94
5	11.85	12.09	12.34	-1.99	2.03
6	11.35	11.59	11.83	-2.07	2.03
7	10.88	11.11	11.35	-2.07	2.11
8	10.43	10.66	10.89	-2.16	2.11
9	9.999	10.230	10.450	-2.26	2.11
10	9.590	9.816	10.040	-2.30	2.23

5. ELECTRICAL DATA

T [°C]	Rmin [K Ω]	Rnom [K Ω]	Rmax [K Ω]	DR(MIN)%	DR(MAX)%
11	9.199	9.422	9.647	-2.37	2.33
12	8.826	9.047	9.269	-2.44	2.40
13	8.470	8.689	8.910	-2.52	2.48
14	8.129	8.347	8.567	-2.61	2.57
15	7.804	8.021	8.240	-2.71	2.66
16	7.493	7.709	7.928	-2.80	2.76
17	7.196	7.412	7.630	-2.91	2.86
18	6.912	7.127	7.346	-3.02	2.98
19	6.640	6.855	7.074	-3.14	3.10
20	6.381	6.595	6.815	-3.24	3.23
21	6.132	6.347	6.567	-3.39	3.35
22	5.894	6.109	6.330	-3.52	3.49
23	5.667	5.882	6.103	-3.66	3.62
24	5.449	5.664	5.886	-3.80	3.77
25	5.240	5.456	5.678	-3.96	3.91
26	5.048	5.260	5.478	-4.03	3.98
27	4.864	5.072	5.286	-4.10	4.05
28	4.687	4.891	5.101	-4.17	4.12
29	4.517	4.717	4.924	-4.24	4.20
30	4.355	4.550	4.753	-4.29	4.27
31	4.198	4.390	4.589	-4.37	4.34
32	4.048	4.236	4.431	-4.44	4.40
33	3.904	4.089	4.280	-4.52	4.46
34	3.766	3.946	4.134	-4.56	4.55
35	3.663	3.810	3.994	-3.86	4.61
36	3.506	3.679	3.859	-4.70	4.66
37	3.383	3.552	3.729	-4.76	4.75
38	3.265	3.431	3.604	-4.84	4.80
39	3.152	3.314	3.484	-4.89	4.88
40	3.043	3.202	3.368	-4.97	4.93
41	2.938	3.094	3.257	-5.04	5.00
42	2.838	2.990	3.149	-5.08	5.05
43	2.741	2.890	3.046	-5.16	5.12
44	2.648	2.793	2.946	-5.19	5.19
45	2.558	2.701	2.850	-5.29	5.23
46	2.472	2.611	2.758	-5.32	5.33
47	2.389	2.525	2.669	-5.39	5.40
48	2.309	2.443	2.583	-5.49	5.42
49	2.232	2.363	2.500	-5.54	5.48
50	2.158	2.286	2.421	-5.60	5.58
51	2.087	2.212	2.344	-5.65	5.63
52	2.018	2.140	2.269	-5.70	5.69
53	1.952	2.072	2.198	-5.79	5.73

5. ELECTRICAL DATA

T [°C]	Rmin [K Ω]	Rnom [K Ω]	Rmax [K Ω]	DR(MIN)%	DR(MAX)%
54	1.888	2.005	2.129	-5.84	5.82
55	1.827	1.941	2.062	-5.87	5.87
56	1.767	1.880	1.998	-6.01	5.91
57	1.710	1.820	1.936	-6.04	5.99
58	1.655	1.763	1.876	-6.13	6.02
59	1.602	1.707	1.818	-6.15	6.11
60	1.551	1.654	1.762	-6.23	6.13
61	1.502	1.602	1.709	-6.24	6.26
62	1.452	1.553	1.657	-6.50	6.28
63	1.409	1.505	1.606	-6.38	6.29
64	1.364	1.458	1.558	-6.45	6.42
65	1.322	1.413	1.511	-6.44	6.49
66	1.280	1.370	1.466	-6.57	6.55
67	1.241	1.328	1.422	-6.55	6.61
68	1.202	1.288	1.379	-6.68	6.60
69	1.165	1.249	1.339	-6.73	6.72
70	1.129	1.211	1.299	-6.77	6.77
71	1.095	1.175	1.261	-6.81	6.82
72	1.061	1.140	1.224	-6.93	6.86
73	1.029	1.106	1.188	-6.96	6.90
74	0.9977	1.073	1.153	-7.02	6.94
75	0.9676	1.041	1.120	-7.05	7.05
76	0.9385	1.011	1.088	-7.17	7.08
77	0.9104	0.9810	1.056	-7.20	7.10
78	0.8833	0.9523	1.026	-7.25	7.18
79	0.8570	0.9246	0.9971	-7.31	7.27
80	0.8316	0.8977	0.9687	-7.36	7.33
81	0.8071	0.8717	0.9412	-7.41	7.38
82	0.7834	0.8466	0.9146	-7.47	7.43
83	0.7604	0.8223	0.8888	-7.53	7.48
84	0.7382	0.7987	0.8639	-7.57	7.55
85	0.7167	0.7759	0.8397	-7.63	7.60
86	0.6958	0.7537	0.8161	-7.68	7.65
87	0.6755	0.7322	0.7933	-7.74	7.70
88	0.6560	0.7114	0.7712	-7.79	7.75
89	0.6371	0.6913	0.7498	-7.84	7.80
90	0.6188	0.6718	0.7291	-7.89	7.86
91	0.6011	0.6530	0.7051	-7.95	7.39
92	0.5840	0.6348	0.6897	-8.00	7.96
93	0.5674	0.6171	0.6709	-8.05	8.02
94	0.5514	0.6000	0.6527	-8.10	8.07
95	0.5359	0.5835	0.6350	-8.16	8.11
96	0.5209	0.5675	0.6179	-8.21	8.16

5. ELECTRICAL DATA

T [°C]	Rmin [K Ω]	Rnom [K Ω]	Rmax [K Ω]	DR(MIN)%	DR(MAX)%
97	0.5064	0.5519	0.6014	-8.24	8.23
98	0.4923	0.5369	0.5853	-8.31	8.27
99	0.4787	0.5224	0.5698	-8.37	8.32
100	0.4655	0.5083	0.5547	-8.42	8.36
101	0.4528	0.4946	0.5401	-8.45	8.42
102	0.4404	0.4814	0.5259	-8.52	8.46
103	0.4284	0.4685	0.5121	-8.56	8.51
104	0.4168	0.4561	0.4988	-8.62	8.56
105	0.4056	0.4440	0.4859	-8.65	8.62
106	0.3947	0.4323	0.4733	-8.70	8.66
107	0.3841	0.4210	0.4611	-8.76	8.70
108	0.3739	0.4100	0.4493	-8.80	8.75
109	0.3640	0.3993	0.4379	-8.84	8.81
110	0.3544	0.3890	0.4267	-8.89	8.84
111	0.3450	0.3789	0.4159	-8.95	8.90
112	0.3360	0.3692	0.4055	-8.99	8.95
113	0.3272	0.3597	0.3953	-9.04	9.01
114	0.3187	0.3505	0.3854	-9.07	9.06
115	0.3104	0.3416	0.3758	-9.13	9.10
116	0.3024	0.3330	0.3665	-9.19	9.14
117	0.2947	0.3246	0.3574	-9.21	9.18
118	0.2871	0.3164	0.3468	-9.26	8.77
119	0.2798	0.3085	0.3401	-9.30	9.29
120	0.2727	0.3008	0.33	-9.34	9.34

6. CONTROL MODEL

6-1 Indoor control mode

1. Major general technical parameters

- 1 Remote receiver distance: 8 m.
- 2 Remote receiver angle: Less than 80 degrees.
- 3 Temperature control accuracy: $\pm 1^{\circ}\text{C}$.
- 4 Time error: Less than 1%.

2. Functions of the controller

Control function

2.1 Emergency switch

Press the emergency button can realize the starting or closing Machine, starting up according to the automatic mode of operation (invalid for duct type air-conditioner)

- ① Press this button to turn ON the unit, the conditioner will be run in auto mode, and press it again to turn off.
- ② When the machine is turned OFF, by press and hold the emergency switch for 5 seconds, with 3 beeps , the indoor unit would turn to emergency run. In such station, machine would be forced to turn to cooling operation with the indoor fan speed being set at high speed, the flaps sweeping and the air conditioner's operation is irrelevant with room temperatures.
- ③ If a remote signal has been received during the emergency run, the machine will operate upon the command of such a remote signal.

2.2 Operator-machine communication

Air conditioning and remote controller is provided with a temperature sensor. The remote controller on the temperature sensor to detect the default settings of room temperature at room temperature. If the indoor control unit for long time have not received remote control signal, will automatically switch to the air conditioner body temperature sensor.

2.3 Timer function

1. Timer on: When set to start in a time by the remote controller, the air conditioner starts in the timer on condition. When the set time is up, the air conditioner will turn on and operates in the preset conditions after receiving a signal from the remote controller. If the air conditioner has not received a signal from the remote controller when the set time is up, it will automatically start and operate in the preset conditions.

2. Timer off: When set to stop in a set time by the remote controller, the air conditioner

6. CONTROL MODEL

will start in the timer off condition. When the set time is up, the air conditioner will turn off after receiving a signal from the remote controller. If the air conditioner has not received a signal from the remote controller when the set time is up, it will turn off automatically.

3. Neither the turning on nor turning off operation will cancel the timer function.

2.4 Sleep

1. In the heating, cooling or dehumidifying mode, press the "Sleep" button on the remote controller to start or cancel the sleep function in turn, and at the same time the sleep icon on the display screen will be on or off accordingly.

2. In the heating mode, the set temperature will decrease automatically after the sleep function is started.

3. In the cooling mode, the set temperature will rise automatically after the sleep function is started.

4. In default, the setting is to cancel the sleep function. Turning off the unit will also cancel the sleep function.

2.5 High efficient run function

In Cool, Dehumidification, Fan mode, press the "HIGH POWER " to enter the refrigeration mode, set the temperature automatically adjust to 18°C; the Fan speed is powerful speed; frequency of high frequency operation.

In the heating mode, powerful function is invalid for H1 wireless remote controller.

2.6 mute function (only for H1 wireless remote controller)

In the indoor machine operation mode , You may turn on mute function and turn off mute function by mute key, The air conditioner will run by mute fan speed in mute mode

2.7 prevent cooling wind mode

In the heating-run, to prevent the indoor fan from blowing cold air, the indoor fan will stop or run slowly until the coil is warmth.

2.8 blow waste heating and waste cooling function

6. CONTROL MODEL

The heating mode, remote shutdown, such as indoor heat exchanger temperature is higher, the wind blowing out opportunities continue to run the waste heat.

Cool and dehumidification mode , after the compressor close, indoor machine will continue to set the speed of operation for a period of time.

2.9 automatically model

This model does not automatically model function, emergency button cannot set the automatic mode of operation, can use the emergency switch shutdown, remote setting the automatic mode of indoor machine with remote signal. (emergency button only for cassette type)

2.10 Dehumidifying method:

Remote control setting dehumidifying mode, indoor machine forced to run at low speed (high power key or a strong bond also maintain a low wind speed) , the outdoor machine according to the refrigeration mode operation.

2.11 Self Recovery of Power Break

When the power supply is recovered after break, all preset are still effective and the air-conditioner can run according to the original setting.

How to set/cancel

It can be set by wire remote controller YXE-C01U/YXE-C02U.

Details see Internal control parameter adjustment.

2.12 FAULT CODE

The fault code can be showed by LED on the indoor panel.

2.13 Filter clean

Filer clean led will light up when air filter is clogged with dust.

How to reset:

- ① Press Emergency switch;
- ② Press high power button for 5s;
- ③ By wire remote controller YXE-C01U/YXE-C02U, press cancel button for 3s.

6. CONTROL MODEL

6-2 Outdoor mode control

Control function

1. Cooling Anti-freeze Protection

To prevent indoor air conditioner evaporator temperature is too low, the indoor coil sensor for real time detection of evaporator. If the indoor coil temperature is too low, the compressor will protect.

2. Overload Protection

Air can heat exchanger temperature sensor for monitoring, when the sensor when the temperature is too high, the compressor will be automatic protection

3. Exhaust temperature protection

To prevent deterioration due to high exhaust temperature of compressor, the machine will realize the real-time detection of the temperature of exhaust gas. If the temperature is too high compressor automatic protection

4. Oil-return Control

When the compressor runs for a long time low frequencies, control system will start the return oil program. The system in the oil return to the compressor.

5. Operation Mode

Air conditioning mode is the operation mode set by users through remote controller, four modes are available: cooling, heating, dehumidification, as well as fan mode.

6. Four-way Valve Control

6. CONTROL MODEL

Four-way valve of the outdoor machine shuts down when cooling and defrosting but starts when heating. During the heating process, the four way valve to stop working for a period of time after compressor disconnect.

7. Start-up Protection:

To prevent compressor from restart frequently in the condition that system pressure has not been completely balanced, it can't be restarted within 3 minutes.

8. Pressure Protection:

When the pressure increases to a preset value, the pressure switch will automatically protect. Compressor will stop and report the fault code protection.

7. TROUBLE SHOOTING

Trouble guide

When the air conditioner failure occurs, the fault code will displays on control board , wire remote controller or display panel.

HOW TO CHECK FAULT CODES

INDOOR UNIT

1.WALL MOUNTED TYPE

For Free-match series

Run the air-conditioner by wireless remote controller , continue pressing "SLEEP "button for 4 times, fault codes will flashing rapidly on the LCD . If no fault , display "00".

"ER"shows indoor display panel communication fault with indoor unit control board .

For VRF series

Fault codes flash rapidly on the LCD.

2.FLOOR STANDING TYPE

L5B (indoor box code)series

In the case of no button-locked,continue pressing "CLOCK"button for 8 times ,fault codes will display on the LCD for 10 seconds,automatically disappears after 10seconds.

Continue pressing "SLEEP"button of wireless remote controller for 8 times ,fault codes will display on the LCD for 10 seconds,automatically disappears after 10seconds.

"ER"shows indoor display panel Communication fault with indoor unit control board

L5C(indoor box code) series

Continue pressing "SLEEP"button of wireless remote controller for4 times ,fault codes will display on the LCD for 10 seconds,automatically disappears after 10seconds.

3.DUCT , CASSETTE,CEILING&FLOOR TYPE

(1) ERROR CODES INDICATED BY WIRE REMOTE CONTROLLER(see fig. below)

MOEDL:YXC-A01U(E)

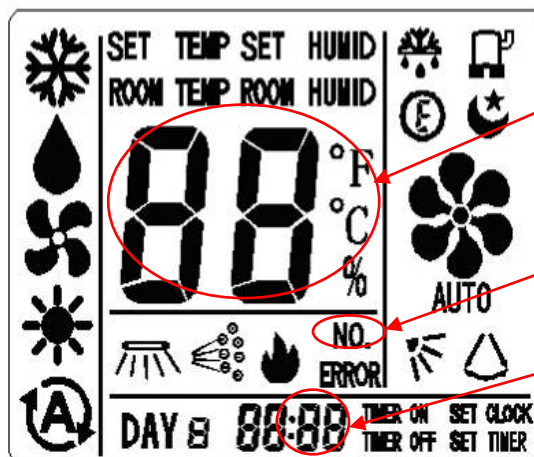

When display "FE" ,shows that the wire controller can't receive the signals of

When failure occurs, this lamp light ON.

This number shows ERROR CODE.

7. TROUBLE SHOOTING

MOEDL:YXE-C01U

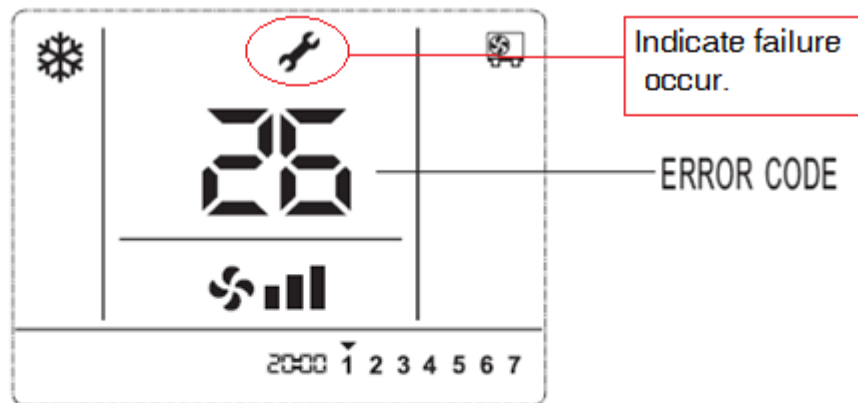

When the airconditioner is malfunction,  will display on the LCD, and error codes will appear and blink.

FIG.2 ERROR CODE DISPLAY ON WIRE REMOT CONTROLLER

(2) CHECK ERROR CODES BY DISPLAY PANEL(CASSETTE type and CEILING & FLOOR type)

Display by lamp indicator

Lamp RUN(LED2 ,red) and Lamp DEFROST (LED5 ,green) flashing, Lamp RUN display fault code ten digit number, lamp DEFROST display fault code single digit number (as shown fig. below).

For example, fault code 36: led RUN& defrost flash 3 times at the same time, and led DEFROST continue flash 3 times, reports No. 36 fault.

7. TROUBLE SHOOTING

CASSETTE TYPE

Display Panel-12K,18K

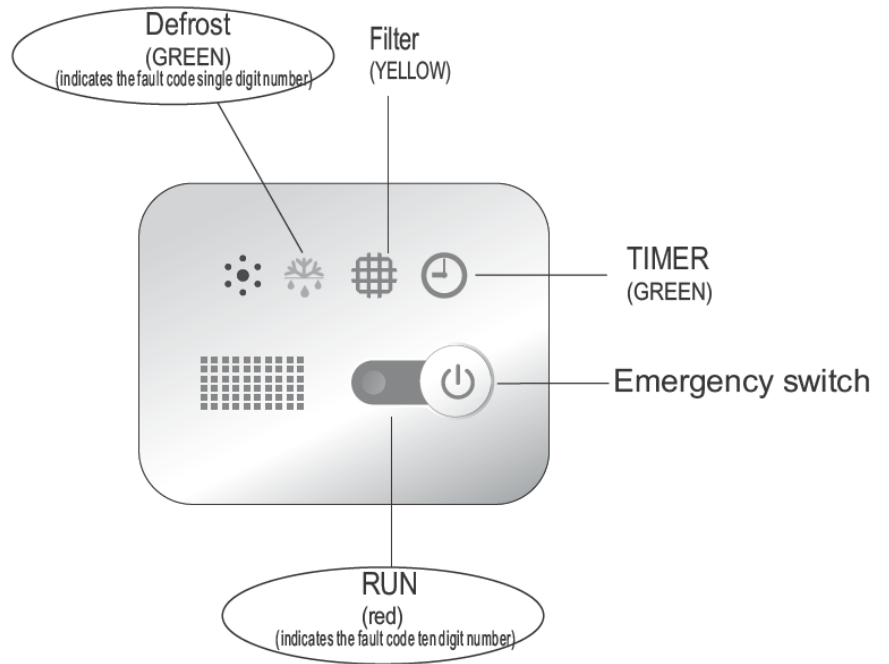

Display Panel-24K,36K,48K

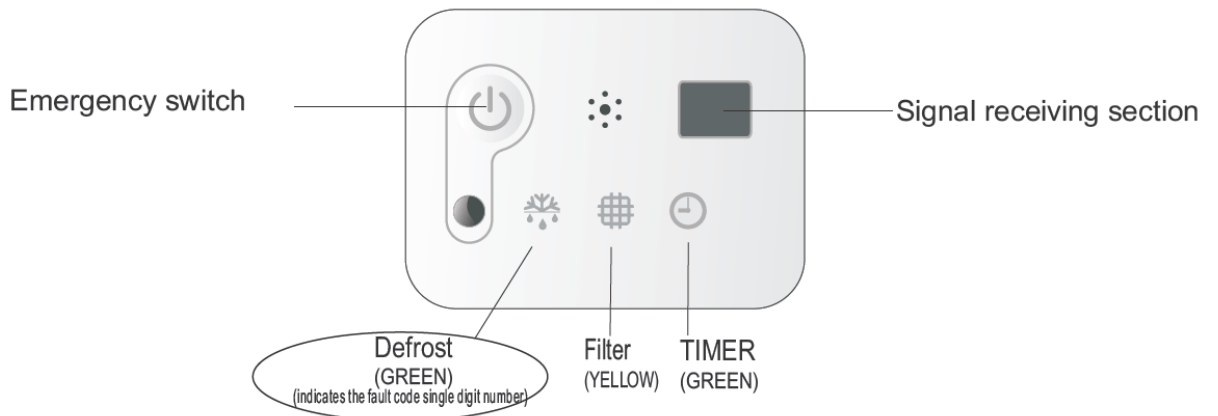

7. TROUBLE SHOOTING

CEILING & FLOOR TYPE

Display Panel

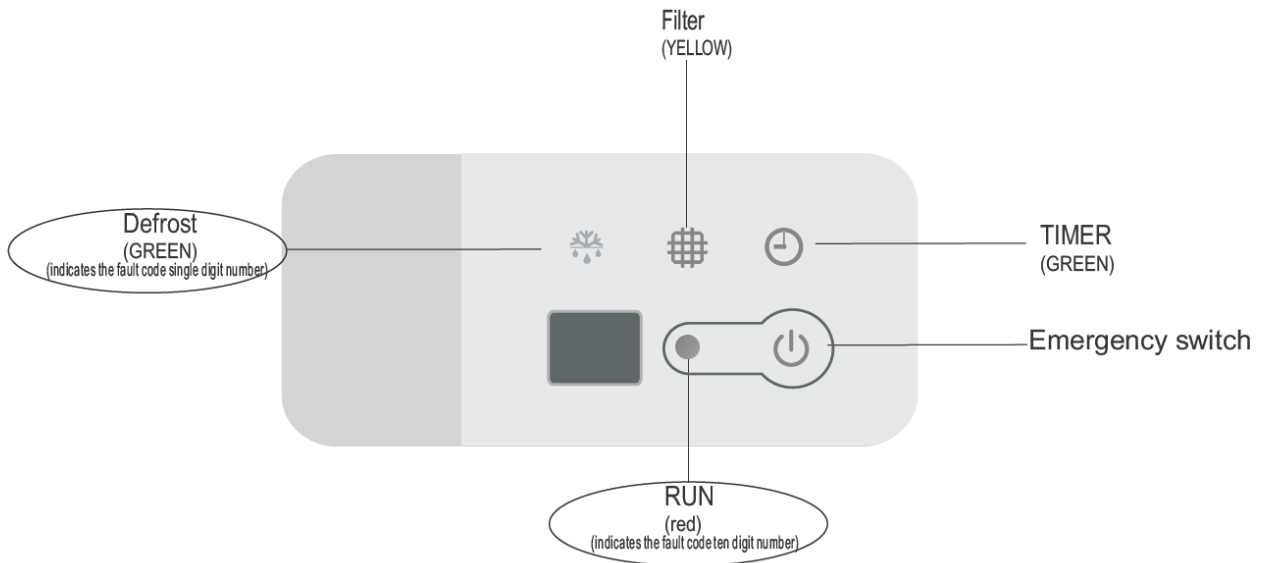

LED FLASH CONTROL: flash 300mS(T1), off 300mS(T2), after 2000mS(T3) fault code repeat displays. (as shown below)

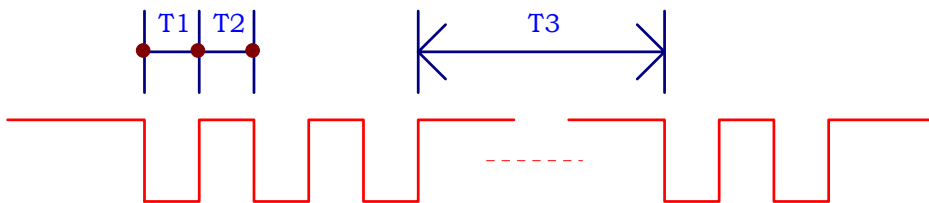
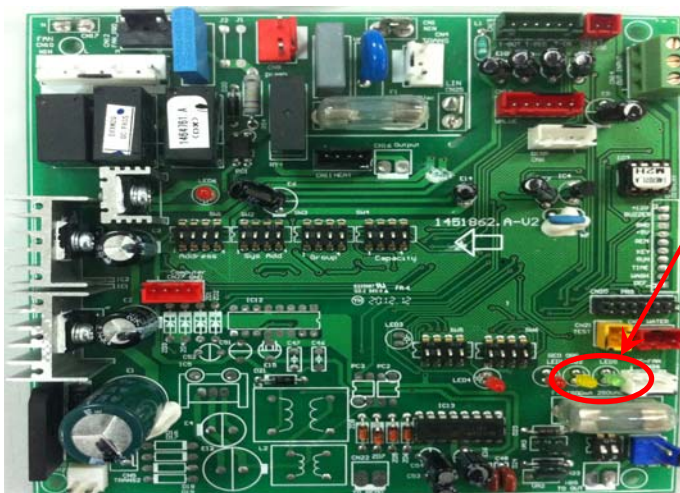

Fig.2 LED FLASH CONTROL

3. Duct type indoor units of VRF---FAULT CODE DISPLAY BY INDOOR BOARD



LED2 and LED5 are failure indicate lamps,
LED2 (YELLOW) indicate fault code ten digit number, LED5 (GREEN) indicate single digit number code

7. TROUBLE SHOOTING

2.OUTDOOR UNIT FAULT CODE DISPLAY

(1) ON/OFF UNITARY TYPE (with outdoor control box)

Fault code display by indicate lamps of outdoor control board flash.

The times that the lamp flashes equal to fault code.

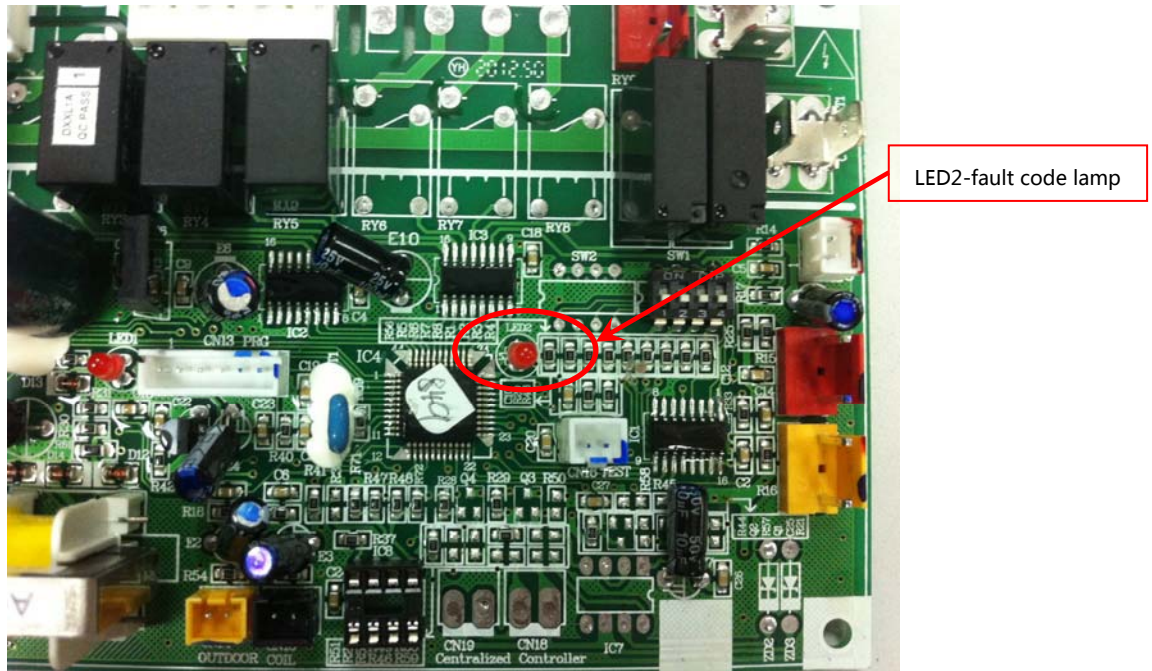

LED FLASH CONTROL: flash 300mS(T1), off 300mS(T2), after 900mS(T3)fault code repeat displays.

(as shown below)

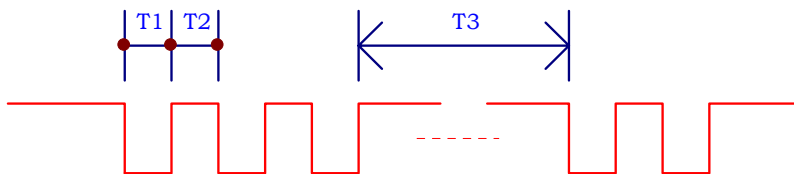

(2) INVERTER UNITARY AIR CONDITONER , MULTI-SPLIT TYPE AIR CONDITONER&VRF: Fault code will display on digital tube board.

7. TROUBLE SHOOTING

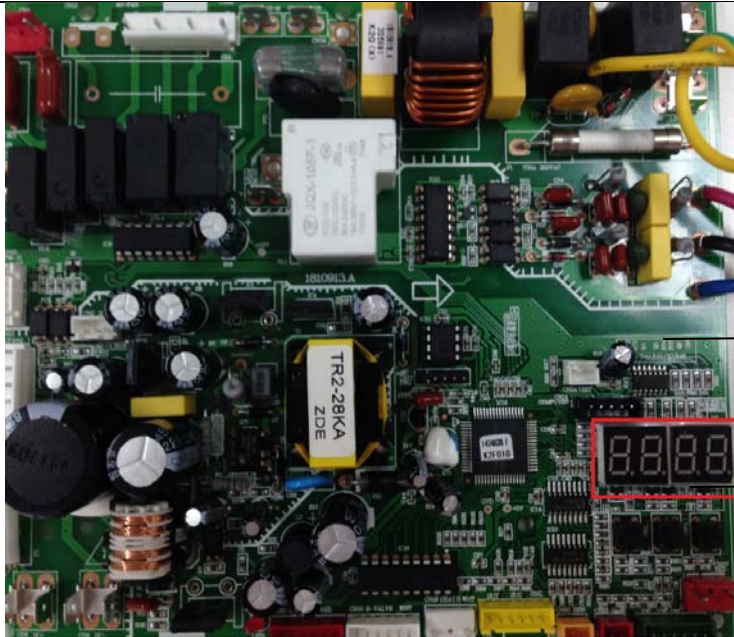

Outdoor Control Board

Digital Tube

FOR INVERTER UNITARY AIR CONDITONER&VRF



E shows failure occur

Display ERROR Code

* VRF:

Indoor unit can indicate both indoor failure and outdoor failure ,but outdoor only indicate outdoor's.

FOR MULTI-SPLIT TYPE

Error code display on digital tube board directly.

7. TROUBLE SHOOTING

3. Fault code display (Driver Board)

The lamp of driver board flash shows failure occur.

Or, fault code can be check on digital tube board .

7. TROUBLE SHOOTING

The following is the fault code table of outdoor.

sheet 1 Outdoor Error Code

Fault code	Fault Description	Possible Reason of Abnormality	How to Deal With	REMARKS
1	Outdoor ambient temperature sensor fault	<ol style="list-style-type: none"> 1.The outdoor ambient temperature sensor connect loose; 2.The outdoor ambient temperature sensor is failure; 3.The sampling circuit is failure 	<ol style="list-style-type: none"> 1.Reconnect the outdoor ambient temperature sensor; 2.Replace the outdoor ambient temperature sensor components; 3.Replace the outdoor control board components. 	
2	Outdoor coil temperature sensor fault	<ol style="list-style-type: none"> 1.The outdoor ambient temperature sensor connect loose; 2.The outdoor ambient temperature sensor is failure; 3.The sampling circuit is failure 	<ol style="list-style-type: none"> 1.Reconnect the outdoor ambient temperature sensor; 2.Replace the outdoor ambient temperature sensor components; 3.Replace the outdoor control board components. 	
3	The unit over-current turn off fault	<ol style="list-style-type: none"> 1.Control board current sampling circuit is failure; 2.The current is over high because of the supply voltage is too low 3.The on-off compressor is blocked 4. Overload in cooling mode 5.Overload in heating mode 	<ol style="list-style-type: none"> 1. Replace the electrical control board components; 2. Normally protection 3. Replace the compressor 4. Please see the Note 3 5. Please see the Note 4 	
4	EEProm Data error	<ol style="list-style-type: none"> 1.EE components is failure; 2.EE components control circuit failure; 3.EE components insert incorrect 	<ol style="list-style-type: none"> 1.Replace the EE components; 2.Replace the outdoor control board components; 3.Reassembly the EE components. 	
5	Cooling freezing protection(the indoor coil temperature is too low) or heating overload(indoor coil temperature is too high)	<ol style="list-style-type: none"> 1.The indoor unit can not blow air normally; 2.The room temperature is too low in cooling mode or the room temperature is too high in heating; 3.The filter is dirty; 4.The duct resistance of the duct 5.The setting fan speed is too low 6. The indoor unit has been installed without standard 	<ol style="list-style-type: none"> 1.Check the indoor fan, indoor fan motor and evaporator whether normally; 2. Normally protection 3.Clean the filter; 4.Check the volume control valve, duct length etc; 5.Set the speed with high speed; 6.Reinstall the indoor unit refer to the user manual to change the distance between the indoor unit and the wall or ceiling. 	

7. TROUBLE SHOOTING

Fault code	Fault Description	Possible Reason of Abnormality	How to Deal With	REMARKS
6	Motor blockage protection	<ol style="list-style-type: none"> 1.Outdoor ambient temperature sensor fault ; 2. Outdoor coil temperature sensor fault ; 3.Outdoor control board fault. 	<ol style="list-style-type: none"> 1.Replace outdoor ambient temperature sensor ; 2.Replace outdoor coil temperature sensor ; 3.Replace Outdoor control board. 	Applied to ON/OFF air-conditioners with 2 control boards
7	The communication fault between the indoor unit and outdoor unit	<ol style="list-style-type: none"> 1.The connection cable connect wrong between the indoor unit and outdoor unit; 2.The communication cable connect loose; 3.The communication cable is fault; 4.The indoor control board is fault; 5.The outdoor control board is fault; 6.Communication circuit fuse open; 7.The specification of communication cable is incorrect. 	<ol style="list-style-type: none"> 1.Reconnect the connection cable refer to the wiring diagram; 2.Reconnect the communication cable; 3.Replace the communication cable; 4.Replace the indoor control board; 5.Replace the outdoor control board; 6.Check the communication circuit, adjust the DIP switch and the short-circuit fuse. 7.Choose suitable communication cable refer to the user manual 	
8	Phase current imbalance	<ol style="list-style-type: none"> 1.The supply voltage fluctuates more than 4%; 2.The compressor power cord connect loose; 3.The AC contactor is fault; 4.The compressor motor fault. 	<ol style="list-style-type: none"> 1.Normally protection; 2.Reconnect the wire refer to the wiring diagram; 3.Replace the AC contactor; 4.Replace the compressor. 	Application of three-phase power supply models
9	U phase current fault	<ol style="list-style-type: none"> 1.Compressor U phase power cord is fault or connect wrong; 2.Outdoor control board is fault; 3.The Compressor is fault 	<ol style="list-style-type: none"> 1.Replace the U phase power cord or reconnect the U phase power cord refer to the wiring diagram; 2.Replace the outdoor control board; 3.Replace the compressor. 	Application of three-phase power supply models
10	V phase current fault	<ol style="list-style-type: none"> 1.Compressor V phase power cord is fault or connect wrong; 2.The outdoor control board is fault; 3.The compressor is fault 	<ol style="list-style-type: none"> 1.Replace the V phase power cord or reconnect the V phase power cord refer to the wiring diagram; 2.Replace the outdoor control board; 3.Replace the compressor. 	Application of three-phase power supply models
11	phase wrong failure	<ol style="list-style-type: none"> 1.Three-phase power is abnormal; 2.The outdoor wiring connect wrong; 3. The outdoor control board is failure 	<ol style="list-style-type: none"> 1.Normally protection, please check the supply power 2.Check the wiring connection refer to the wiring diagram; 	Application of three-phase power

7. TROUBLE SHOOTING

Fault code	Fault Description	Possible Reason of Abnormality	How to Deal With	REMARKS
			3. Replace the outdoor control board	supply models
12	voltage absent phase	<ol style="list-style-type: none"> 1. Three-phase power is abnormal; 2. The outdoor wiring connect wrong; 3. The outdoor control board is failure. 	<ol style="list-style-type: none"> 1. Normally protection 2. Check the wiring connection refer to the wiring diagram; 3. Replace the outdoor control board 	Application of three-phase power supply models
13	Compressor overheat protector device	<ol style="list-style-type: none"> 1. The wiring of the overload protector connect loose. 2. The overload protector is failure . 3. The refrigerant is not enough; 4. The installation pipe is too long than normal, but not add the enough refrigerant; 5. The expansion valve is failure; 6. The outdoor control board is failure 	<ol style="list-style-type: none"> 1. Reconnect the wiring of the overload protector; 2. Replace the overload protector; 3. Check the welding point of the unit to confirm whether it is leakage, and then recharge the refrigerant; 4. Add the refrigerant; 5. Replace expansion valve; 6. Replace the outdoor control board. 	
14	the high pressure switch operate or the unit turn off for high pressure protection	<ol style="list-style-type: none"> 1. The wiring of the high pressure protector connect loose; 2. The high pressure protector is failure; 3. The outdoor control board is abnormal; 4. Overload in cooling; 5. Overload in heating. 	<ol style="list-style-type: none"> 1. Reconnect the wiring the high pressure protector; 2. Replace the high pressure protector; 3. Replace the outdoor control board; 4. Please refer to the Note 3; 5. Please refer to the Note 4. 	Applied to models with high pressure switch or pressure sensor
15	the low pressure switch protection or the unit turn off for low pressure protection	<ol style="list-style-type: none"> 1. The low pressure switch is failure; 2. The wiring of the low pressure switch connect loose; 3. The refrigerant is not enough; 4. The expansion valve failure in heating mode; 5. The outdoor control board is abnormal. 	<ol style="list-style-type: none"> 1. Reconnect the wiring of the low pressure switch; 2. Replace the low pressure switch; 3. Check the welding point to confirm whether the unit is leakage, and then add some refrigerant; 4. Replace the expansion valve; 5. Replace the outdoor control board. 	Applied to models with low pressure switch or pressure sensor
16	overload protection in cooling mode	System overload	Please refer to the Note 3.	
17	Discharge temperature sensor fault	<ol style="list-style-type: none"> 1. The wiring of the discharge temperature sensor connect loose; 2. The discharge temperature sensor is failure; 3. The sampling circuit is abnormal. 	<ol style="list-style-type: none"> 1. Reconnect the wiring of the discharge temperature sensor; 2. Replace the discharge temperature sensor; 3. Replace the outdoor control board. 	
18	AC voltage is abnormal	<ol style="list-style-type: none"> 1. The AC voltage >275V or <160V. 2. The AC voltage of sampling circuit on the driver board is abnormally 	<ol style="list-style-type: none"> 1. Normally protection, please check the supply power; 2. Replace the driver board. 	MUTI-SPLIT TYPE ONLY

7. TROUBLE SHOOTING

Fault code	Fault Description	Possible Reason of Abnormality	How to Deal With	REMARKS
19	Suction temperature sensor fault	<ol style="list-style-type: none"> 1.The wiring of the suction temperature sensor connect loose; 2. The suction temperature sensor is failure; 3. The sampling circuit is abnormally 	<ol style="list-style-type: none"> 1.Reconnect the wiring of the suction temperature sensor; 2.Replace the suction temperature sensor; 3.Replace the outdoor control board. 	
20	The temperature sensor for the inlet tube of the condenser fault	<ol style="list-style-type: none"> 1.The wiring of the temperature sensor for the inlet tube connect loose; 2.The temperature sensor for the inlet tube is failure; 3.The sampling circuit is abnormally 	<ol style="list-style-type: none"> 1.Reconnect the wiring of the temperature sensor for the inlet tube of the condenser; 2.Replace the temperature sensor for the inlet tube of the condenser; 3.Replace the outdoor control board. 	
21	The outlet tube of the condenser temperature sensor fault	<ol style="list-style-type: none"> 1.The wiring of the temperature sensor for the outlet tube connect loose; 2.The temperature sensor for the outlet tube is failure; 3.The sampling circuit is abnormally 	<ol style="list-style-type: none"> 1. Reconnect the wiring of the temperature sensor for the outlet tube of the condenser. 2.Replace the temperature sensor for the outlet tube of the condenser; 3.Replace the outdoor control board. 	
22	The defrosting sensor fault	<ol style="list-style-type: none"> 1.The wiring of the defrosting sensor connect loose; 2.The defrosting sensor is failure; 3.The sampling circuit is abnormally 	<ol style="list-style-type: none"> 1. Reconnect the wiring of the defrosting sensor; 2. Replace the defrosting sensor; 3. Replace the outdoor control board. 	
23	Expansion valve A tube(thin) sensor fault	<ol style="list-style-type: none"> 1. The wiring of the sensor for the expansion valve A(thin tube) connect loose; 2.The sensor for the expansion A(thin tube) is failure; 3. The sampling circuit is abnormally 	<ol style="list-style-type: none"> 1. Reconnect the wiring of the sensor for the expansion valve A(thin tube); 2. Replace the sensor for the expansion valve A(thin tube); 3. Replace the outdoor control board. 	FOR MUTI-SPLIT & Inverter unitary types
24	Expansion valve B (thin)tube sensor fault	<ol style="list-style-type: none"> 1. The wiring of the sensor for the expansion valve B (thin tube) connect loose; 2.The sensor for the expansion valve B(thin tube) is failure; 3.The sampling circuit is abnormally 	<ol style="list-style-type: none"> 1.Reconnect the wiring of the sensor for the expansion valve B(thin tube); 2.Replace the sensor for the expansion valve B(thin tube); 3. Replace the outdoor control board. 	FOR MUTI-SPLIT outdoor
25	Expansion valve C (thin)tube sensor fault	<ol style="list-style-type: none"> 1. The wiring of the sensor for the expansion valve C(thin tube) connect loose; 2.The sensor of the expansion valve C (thin tube) is failure; 3.The sampling circuit is abnormally 	<ol style="list-style-type: none"> 1. Reconnect the wiring of the sensor for the expansion valve C(thin tube); 2. Replace the sensor for the expansion valve C(thin tube); 3. Replace the outdoor control board. 	FOR MUTI-SPLIT outdoor
26	Expansion valve D (thin)tube sensor fault	<ol style="list-style-type: none"> 1.The wiring of the sensor for the expansion valve D(thin tube) connect loose; 2.The sensor of the expansion valve D (thin tube) is failure; 3.The sampling circuit is abnormally 	<ol style="list-style-type: none"> 1. Reconnect the wiring of the sensor for the expansion valve D(thin tube); 2. Replace the sensor for the expansion valve D(thin tube); 3. Replace the outdoor control board. 	FOR MUTI-SPLIT outdoor
27	Expansion valve A (thick tube) sensor fault	<ol style="list-style-type: none"> 1. The wiring of the sensor for the expansion valve A(thick tube) connect loose; 	<ol style="list-style-type: none"> 1. Reconnect the wiring of the sensor for the expansion valve A(thick tube); 	FOR MUTI-SPLIT

7. TROUBLE SHOOTING

Fault code	Fault Description	Possible Reason of Abnormality	How to Deal With	REMARKS
		2.The sensor of the expansion valve A (thick tube) is failure; 3.The sampling circuit is abnormally	2. Replace the sensor for the expansion valve A(thick tube); 3. Replace the outdoor control board.	&inverter unitary types
28	Expansion valve B (thick tube) sensor fault	1. The wiring of the sensor for the expansion valve B(thick tube) connect loose; 2.The sensor of the expansion valve B (thick tube) is failure; 3. The sampling circuit is abnormally	1. Reconnect the wiring of the sensor for the expansion valve B(thick tube); 2. Replace the sensor for the expansion valve B(thick tube); 3. Replace the outdoor control board.	FOR MUTI-SPLIT outdoor
29	Expansion valve C (thick tube) sensor fault	1. The wiring of the sensor for the expansion valve B(thick tube) connect loose; 2.The sensor of the expansion valve C (thick tube) is failure; 3. The sampling circuit is abnormally	1. Reconnect the wiring of the sensor for the expansion valve B(thick tube); 2. Replace the sensor for the expansion valve C(thick tube); 3. Replace the outdoor control board.	FOR MUTI-SPLIT outdoor
30	Expansion valve D (thick tube) sensor fault	1. The wiring of the sensor for the expansion valve B(thick tube) connect loose; 2.The sensor of the expansion valve D (thick tube) is failure; 3. The sampling circuit is abnormally	1. Reconnect the wiring of the sensor for the expansion valve B(thick tube); 2. Replace the sensor for the expansion valve D(thick tube); 3. Replace the outdoor control board.	FOR MUTI-SPLIT outdoor
31	The discharge pressure is too high	1. Overload in cooling; 2. Overload in heating	1. Overload in cooling; 2. Overload in heating	VRF outdoor
32	The suction pressure is too low fault	1.The refrigerate is not enough for the unit; 2.The expansion valve is failure in heating mode; 3.The outdoor ambient temperature is too low in heating mode	1.Check the welding point to confirm whether it exist the leakage point, and then add some refrigerate; 2. Replace the expansion valve; 3.The unit should operate within allowable temperature range.	VRF outdoor
40	high pressure and low pressure imbalance before compressor start	1.The wiring of the high/low pressure sensor connect loose; 2.The wiring of the bypass valve connect loose; 3. High/low pressure sensor is failure; 4.Bypass coil is failure. 5.Bypass valve is failure. 6.The capillary that connect with bypass valve blockage 7.The outdoor control board is fault;	1.Reconnect the wiring of high/low pressure sensor . 2..Reconnect the wiring of the bypass valve ; 3.Replace pressure sensor. 4.Replace bypass valve coil. 5.Replace bypass coil. 6.Check whether blockage occur. 7.Replace outdoor control board.	VRF outdoor
42	the voltage sensor fault	1.The wiring of the voltage sensor connect wrong or loose; 2. The voltage sensor is failure; 3. The sampling circuit of the voltage sensor is failure.	1. Reconnect the wiring of the current sensor; 2. Replace the voltage sensor; 3. Replace the outdoor control board.	
43	High Pressure sensor fault	1.The wiring of the high-pressure pressure sensor connect loose;	1.Reconnect the wiring of the high-pressure pressure sensor;	VRF

7. TROUBLE SHOOTING

Fault code	Fault Description	Possible Reason of Abnormality	How to Deal With	REMARKS
		2.The high-pressure pressure sensor is failure 3.The sampling circuit of the high-pressure pressure sensor is failure	2.Replace the high-pressure pressure sensor; 3.Replace the outdoor control board.	
44	Low Pressure sensor fault	1.The wiring of the low-pressure pressure sensor connect loose; 2.The low-pressure pressure sensor is failure 3.The sampling circuit of the low-pressure pressure sensor is failure.	1.Reconnect the wiring of the low-pressure pressure sensor; 2.Replace the low-pressure pressure sensor; 3.Replace the outdoor control board.	
45	IPM fault	There are many reasons for this failure, If you need further analysis, fault code of the driver board is needed by watching the driver board fault led. Analysis can be further to know why and how to operate. Specific see table 5, table 6.	See attached "analysis of the driving board fault".	Applied for INVERTER type
46	IPM and control board communication fault	1.The cable between the control board and the driver board connect loose; 2.The cable between the control board and the driver board is failure; 3.The driver board is failure 4.The control board is failure	1.Reconnect the cable between the control board and the driver board; 2.Replace the communication cable between the control board and the driver board; 3.Replace the driver board; 4.Replace the control board.	Applied for Inverter Unitary type&Free-Match
46-1	IPM and control board communication fault	1.The cable between the control board and the driver board connect loose; 2.The cable between the control board and the driver board is failure; 3.The driver board is failure 4.The control board is failure	1.Reconnect the cable between the control board and the driver board; 2.Replace the communication cable between the control board and the driver board; 3.Replace the driver board; 4.Replace the control board.	Applied for VRF
46-2	Replenish gas board and control board communication fault	1.The cable between the control board and replenish gas board connect loose; 2.The cable between the control board and replenish gas board is failure; 3.The replenish gas board is failure 4.The control board is failure	1.Reconnect the cable between the control board and the replenish gas board; 2.Replace the communication cable between the control board and the replenish gas board; 3.Replace the replenish gas board ; 4.Replace the control board.	Applied for VRF
47	Discharge temperature too high fault	1. The refrigerant of the unit is not enough; 2.The refrigerant of the unit is not enough due to add the length of the installation pipe 3.Throttling service is failure; 4.The outdoor ambient temperature is too high	1.Check the welding point to confirm whether the unit has exist leakage point, and then add some refrigerant. 2.Add some refrigerant refer to the installation user manual; 3.Replace the throttling service(such	

7. TROUBLE SHOOTING

Fault code	Fault Description	Possible Reason of Abnormality	How to Deal With	REMARKS
			as capillary, expansion valve) 4. Normally protection.	
48	the outdoor DC fan motor fault (upper fan motor)	<ol style="list-style-type: none"> 1.The wiring of the up DC fan motor connect loose; 2. The cord of the up DC fan motor is failure; 3.The up DC fan motor is failure; 4. The drive circuit of the up DC fan motor is failure; 5. The outdoor fan has been blocked. 	<ol style="list-style-type: none"> 1.Reconnect the wiring of the up DC fan motor; 2.Replace the up DC fan motor; 3. Replace the up DC fan motor; 4.Replace the driver board of the fan motor; 5. Check the outdoor fan and ensure the outdoor fan can run normally. 	
48-1	the outdoor upper DC fan motor Locked rotor fault	<ol style="list-style-type: none"> 1.The fan motor motor rotation blockage; 2. The fan motor is failure; 3.The outdoor control board is failure; 4. The driver board is failure; 	<ol style="list-style-type: none"> 1. Remove the fan motor locked-rotor sundry, recover motor operating conditions; 2. Replace the upper DC fan motor; 3. Replace the outdoor control board ; 4 .Replace the driver board . 	VRF
48-2	the outdoor upper DC fan motor stall fault	<ol style="list-style-type: none"> 1. The fan motor is failure; 2.The outdoor control board is failure; 3. The driver board is failure; 	<ol style="list-style-type: none"> 1. Replace the upper fan motor; 2. Replace the outdoor control board ; 3 .Replace the driver board . 	VRF
49	the outdoor DC fan motor fault (down fan motor)	<ol style="list-style-type: none"> 1.The wiring of the down DC fan motor connect loose; 2.The cord of the down DC fan motor is failure; 3. The down DC fan motor is failure; 4. The drive circuit of the down DCfan motor is failure; 5. The outdoor fan has been blocked. 	<ol style="list-style-type: none"> 1. Reconnect the wiring of the down DC fan motor; 2. Replace the down DC fan motor; 3.Replace the down DC fan motor; 4.Replace the driver board of the fan motor; 5. Check the outdoor fan and ensurethe outdoor fan can run normally. 	
49-1	the outdoor lower DC fan motor Locked rotor fault	<ol style="list-style-type: none"> 1.The fan motor motor rotation blockage; 2. The fan motor is failure; 3.The outdoor control board is failure; 4. The driver board is failure; 	<ol style="list-style-type: none"> 1. Remove the fan motor locked-rotor sundry, recover motor operating conditions; 2. Replace the lower DC fan motor; 3. Replace the outdoor control board ; 4 .Replace the driver board . 	VRF
49-2	he outdoor lower DC fan motor stall fault	<ol style="list-style-type: none"> 1. The fan motor is failure; 2.The outdoor control board is failure; 3. The driver board is failure; 	<ol style="list-style-type: none"> 1. Replace the lower fan motor; 2. Replace the outdoor control board ; 3 .Replace the driver board . 	VRF

7. TROUBLE SHOOTING

Fault code	Fault Description	Possible Reason of Abnormality	How to Deal With	REMARKS
50	Expansion valve E temperature sensor fault	<ol style="list-style-type: none"> 1. The wiring of the sensor connect loose; 2. The sensor of the expansion valve is failure; 3. The sampling circuit is abnormally 	<ol style="list-style-type: none"> 1. Reconnect the wiring of the sensor; 2. Replace the sensor for the expansion valve E; 3. Replace the outdoor control board. 	FOR Branch Box
63	Current sensor fault	<ol style="list-style-type: none"> 1. The wiring of the current sensor connect loose; 2. The current sensor is failure; 3. The sampling circuit is abnormally 	<ol style="list-style-type: none"> 1. Reconnect the wiring of the sensor; 2. Replace the current sensor; 3. Replace the outdoor control board. 	Application of three-phase power supply ON/OFF unitary models
66	Radiator temperature sensor fault	<ol style="list-style-type: none"> 1. The sensor connect is loose; 2. The current sensor is failure; 3. The sampling circuit is abnormally 	<ol style="list-style-type: none"> 1. Reconnect the wiring ; 2. Replace the temperature sensor; 3. Replace the outdoor control board. 	
67	Radiator temperature protect			
91	The unit turn off due to the IPM board over heating fault	<ol style="list-style-type: none"> 1. The outdoor ambient is too high; 2. The speed of the out fan motor is too low if the fan motor is AC fan motor; 3. The outdoor unit has been installed without standard; 4. The supply power is too low. 	<ol style="list-style-type: none"> 1. Normally protection; 2. Check the fan capacitor, and replace the fan capacitor if it is failure; 3. Reinstalled the outdoor unit refer to the installation user manual; 4. Normally protection. 	
92	the ratio of the discharge pressure than the suction pressure is too large	<ol style="list-style-type: none"> 1. The filter of the expansion valve is dirty; 2. The difference between the indoor room temperature and the outdoor ambient temperature is too large; 3. The refrigerant of the unit is not enough; 4. The expansion is failure or the capillary is failure 5. The outdoor ambient temperature is too low in heating mode 	<ol style="list-style-type: none"> 1. Replace the expansion valve; 2. Normally protection; 3. Check the welding point of the unit to confirm whether it exist leakage point, and then add some refrigerant; 4. Replace the expansion valve or the capillary; 5. Please let the unit operates within the allowable temperature range. 	VRF
93-1	The quantity of the indoor unit is more than the set.	<ol style="list-style-type: none"> 1. Indoor unit quantity set is incorrect ; 2. New indoor unit is added in the system. 	Reset the number of the indoor units.	VRF
93-2	The quantity of the indoor unit is less than the set.	<ol style="list-style-type: none"> 1. Not all of the indoor units are power on; 2. The set quantity of the indoor unit is incorrect; 3. Add or remove some indoor units 	<ol style="list-style-type: none"> 1. Put all the indoor units power on; 2. Reset the quantity of the indoor units; 3. Reset the quantity of the indoor units 	VRF
94	outdoor address conflict	<ol style="list-style-type: none"> 1. Put all the indoor units power on; 2. Reset the quantity of the indoor units; 3. Reset the quantity of the indoor units 	Change the setting address of the outdoor unit	VRF
95	the refrigerant of the unit is excessive fault	The refrigerant of the unit is excessive	Discharge the refrigerant and charge the refrigerant refer to the rating label	VRF

7. TROUBLE SHOOTING

Fault code	Fault Description	Possible Reason of Abnormality	How to Deal With	REMARKS
96	the refrigerant of the unit is not enough fault	The refrigerant of the unit is not enough	Discharge the refrigerant and charge the refrigerant refer to the rating label	VRF
97	4-way valve commutation failure fault	1.The wiring of the 4-way valve coil connect loose; 2.The 4-way valve coil is failure; 3.The 4-way valve is failure; 4.The driver board of the 4-way valve is failure	1. Reconnect the wiring of the 4-way valve; 2. Replace the 4-way valve coil; 3. Replace the 4-way valve; 4.Replace the driver board of the 4-way valve.	FOR VRF&inverter unitary types

7. TROUBLE SHOOTING

The following is the fault code table of indoor.

Sheet 2 Indoor Error Code List

Fault code	Fault Description	Possible Reason of Abnormality	How to Deal With	REMARKS
31	The buttons of the front panel AD fault	<ol style="list-style-type: none"> 1. The buttons are failure; 2. The cable of the display board is failure; 3. The display board is failure; 4. The indoor control board is failure. 	<ol style="list-style-type: none"> 1. Replace the display board; 2. Replace the cable of the display board; 3. Replace the display board; 4. Replace the indoor control board. 	Only for MUTI-SPLIT
32	The front panel fault is not in place	<ol style="list-style-type: none"> 1. The front panel has been blocked; 2. The connection cable of the switch and the motor connect loose; 3. The switch is failure; 4. The motor of the front panel is failure; 5. The indoor control board is failure. 	<ol style="list-style-type: none"> 1. Reassembly the front panel; 2. Reconnect the cable of the switch and panel motor. 3. Replace the switch; 4. Replace the motor of the front panel; 5. Replace the indoor control board. 	Only for MUTI-SPLIT
33	Room temperature sensor fault	<ol style="list-style-type: none"> 1. The cable of the indoor room temperature sensor connect loose; 2. The indoor room temperature sensor is failure; 3. The sampling circuit is abnormal. 	<ol style="list-style-type: none"> 1. Reconnect the cable of the indoor room temperature sensor; 2. Replace the indoor room temperature sensor; 3. Replace the indoor control board. 	Only for MUTI-SPLIT
34	Coil temperature sensor fault	<ol style="list-style-type: none"> 1. The cable of the indoor coil temperature sensor connect loose; 2. The indoor coil temperature sensor is failure; 3. The sampling circuit is abnormal. 	<ol style="list-style-type: none"> 1. Reconnect the cable of the indoor room temperature sensor; 2. Replace the indoor room temperature sensor; 3. Replace the indoor control board. 	Only for MUTI-SPLIT
35	Panel drive fault (two upper and lower panel position detection switch is not in accordance with the reservation timing action)	<ol style="list-style-type: none"> 1. The front panel has been blocked; 2. The connection cable of the switch and the motor connect loose; 3. The switch is failure; 4. The motor of the front panel is failure; 5. The indoor control board is failure. 	<ol style="list-style-type: none"> 1. Reassembly the front panel; 2. Reconnect the cable of the switch and panel motor. 3. Replace the switch; 4. Replace the motor of the front panel; 5. Replace the indoor control board. 	Only for MUTI-SPLIT

7. TROUBLE SHOOTING

Fault code	Fault Description	Possible Reason of Abnormality	How to Deal With	REMARKS
36	Communication between Indoor and outdoor fault	<ol style="list-style-type: none"> 1. The connection cable between the indoor unit and the outdoor unit connect wrong; 2. The communication cable between the indoor unit and the outdoor unit connect loose or the cable between the indoor control board to terminal connect loose or the cable between the outdoor control board to the terminal connect loose; 3. The indoor control board is failure; 4. The outdoor control board is failure; 	<ol style="list-style-type: none"> 1. Reconnect the connection cable refer to the indoor and outdoor wiring diagram; 2. Reconnect the communication cable refer to the indoor and outdoor wiring diagram; 3. Replace the communication cable refer to the indoor and outdoor wiring diagram; 4. Replace the indoor control board; 5. Replace the outdoor control board. 	Only for MUTI-SPLIT
37	Humidity sensor failure	<ol style="list-style-type: none"> 1. The cable of the humidity sensor connect loose; 2. The humidity sensor is failure; 3. The indoor control board is failure. 	<ol style="list-style-type: none"> 1. Reconnect the cable of the humidity sensor; 2. Replace the humidity sensor; 3. Replace the indoor control board. 	Only for MUTI-SPLIT
38	EEprom Data error	<ol style="list-style-type: none"> 1. EE components is failure; 2. The EE control circuit of the control board is failure; 3. The EE components has been inserted with opposite direction. 	<ol style="list-style-type: none"> 1. Replace the EE components; 2. Replace the control board; 3. Reinsert the EE components. 	Only for MUTI-SPLIT
39	The indoor DC fan motor fault	<ol style="list-style-type: none"> 1. The cable of the DC fan motor connect loose; 2. The indoor control board is failure; 3. The indoor fan motor is failure. 	<ol style="list-style-type: none"> 1. The cable of the DC fan motor connect loose; 2. The indoor control board is failure; 3. The indoor fan motor is failure. 	Only for MUTI-SPLIT
40	The grill protection	<ol style="list-style-type: none"> 1. The grill has not been installed in right place; 2. The protection switch is failure; 3. The indoor control board is failure. 	<ol style="list-style-type: none"> 1. Adjust the grill and put it in right place; 2. Replace the switch components; 3. Replace the indoor control board. 	Only for MUTI-SPLIT
41	Zero check fault	Control board is failure.	Replace the indoor control board.	PG motor

7. TROUBLE SHOOTING

Fault code	Fault Description	Possible Reason of Abnormality	How to Deal With	REMARKS
51	Drainage protection	<ol style="list-style-type: none"> 1. The water level of the drain pan exceed safe level; 2. The cable of the water level switch connect loose; 3. The water level switch is failure; 4. The control board is failure. 	<ol style="list-style-type: none"> 1. Check whether there are something to block the drain hose or the height of the drain hose is too high; 1.2 Check the water pump and replace the water pump if the water pump is failure; 2. Reconnect the cable of the water level switch refer to the wiring diagram; 3. Replace the water level switch; 4. Replace the control board. 	
52	The grill protection	<ol style="list-style-type: none"> 1. The grill has not been installed in right place; 2. The protection switch is failure; 3. The control board is failure. 	<ol style="list-style-type: none"> 1. Adjust the grill and put it in right place; 2. Replace the switch components; 3. Replace the indoor control board. 	
53	The upper panel is not in place to protection	<ol style="list-style-type: none"> 1. The front panel has been blocked; 2. The cable of the switch and the motor connect loose; 3. The switch is failure; 4. The panel motor is failure; 5. The indoor control board is failure. 	<ol style="list-style-type: none"> 1. Reassembly the front panel; 2. Reconnect the cable of the switch and the panel motor; 3. Replace the switch components; 4. Replace the panel motor; 5. Replace the indoor control board. 	
54	The lower panel is not in place to protection	<ol style="list-style-type: none"> 1. The front panel has been blocked; 2. The cable of the switch and the motor connect loose; 3. The switch is failure; 4. The panel motor is failure; 5. The indoor control board is failure. 	<ol style="list-style-type: none"> 1. Reassembly the front panel; 2. Reconnect the cable of the switch and the panel motor; 3. Replace the switch components; 4. Replace the panel motor; 5. Replace the indoor control board. 	
55	Mode Conflict Fault	The user set the conflicting mode for more than two indoor units	Reset the operate mode for the indoor unit, for the one outdoor unit, the user should avoid to set the conflicting operate mode with the indoor units	ONLY FOR MUTI-SPLIT & VRF TYPES
56	Water tank water temperature sensor 1 fault	<ol style="list-style-type: none"> 1. The cable of the water tank water temperature sensor 1 connect loose; 2. The cable of the water tank water temperature sensor 1 circuit is abnormal; 3. The cable of the water tank water temperature sensor 1 is failure. 	<ol style="list-style-type: none"> 1. Reconnect the cable of the water temperature sensor 1; 2. Change the cable . 3. Replace the water temperature sensor 1 . 4. Replalce indoor control board . 	Only for heat pump water heater

7. TROUBLE SHOOTING

Fault code	Fault Description	Possible Reason of Abnormality	How to Deal With	REMARKS
		4.Indoor control board is failure.		
57	Water tank water temperature sensor 2fault	<ol style="list-style-type: none"> 1. The cable of the water tank water temperature sensor 2 connect loose; 2. The cable of the water tank water temperature sensor 2 circuit is abnormal; 3. The cable of the water tank water temperature sensor 2 is failure. 4.Indoor control board is failure. 	<ol style="list-style-type: none"> 1. Reconnect the cable of the water temperature sensor 2; 2. Change the cable . 3. Replace the water temperature sensor 2 . 4.Repalce indoor control board . 	Only for heat pump water heater
58	Coil temperature sensor (liquid tube)fault	<ol style="list-style-type: none"> 1.The coil temperature sensor (liquid tube)connect loose; 2.The coil temperature sensor(liquid tube) is failure; 3.The control board is failure 	<ol style="list-style-type: none"> 1.Reconnect the coil temperature sensor; 2.Replace the coil temperature sensor components; 3.Replace the control board components. 	Only for heat pump water heater
59	Liquid tube temperature protect	<ol style="list-style-type: none"> 1.The resistance of temperature sensor is abnormal. 2.Control board circuit is abnormal. 3.Water temperature in tank is too high(over 70°C) ; 4.No water in tank. 	<ol style="list-style-type: none"> 1.Change temperature sensor. 2.Change Control board . 3.Normally protection,should lower water temperature ; 4.Open fill pump to supply water;Check whether there is leakage occur. 	Only for heat pump water heater
60	water shortage protect	<ol style="list-style-type: none"> 1.Water shortage in tank; 2.Water temperature sensor in tank is abnormal. 3.Control board is abnormal. 	<ol style="list-style-type: none"> 1.Open fill pump to supply water;Check whether there is leakage occur. 2.Change temperature sensor. 3.Change Control board . 	Only for heat pump water heater
61	Indoor address repeat fault	Two or more two indoor units has set with the same address	Reset the address of the indoor unit and it should avoid the address repeat.	For VRF
62	Remote address repeat fault	When the same indoor unit with more than one wiring controller, a number of the address of the wiring controller is same	Reset the address of the wiring controller and avoid the address of the wiring controller repeat.	For VRF
64	Communication between Indoor & Outdoor unit Fault	<ol style="list-style-type: none"> 1. The connection cable between the indoor unit and the outdoor unit connect wrong; 2.The communication cableconnect loose; 3.The communication cable between the 	<ol style="list-style-type: none"> 1. Reconnect the connection cable refer to the indoor and outdoor wiring diagram; 2. Reconnect the communication cable refer to the indoor and outdoor wiring diagram; 3. Replace the communication cable refer to the indoor and outdoor 	

7. TROUBLE SHOOTING

Fault code	Fault Description	Possible Reason of Abnormality	How to Deal With	REMARKS
		indoor unit and the outdoor unit is failure or the cable between the indoor control board to terminal is failure or the cable between the outdoor control board to the terminal is failure; 4. The indoor control board is failure; 5. The outdoor control board is failure.	wiring diagram; 4. Replace the indoor control board; 5. Replace the outdoor control board.	
65	The indoor unit can not receive the sign of the wiring controller	1.The cable of the wiring controller connect loose; 2.The cable of the wiring controller is failure; 3.The wiring controller is failure; 4. The indoor control board is failure.	1.Reconnect the cable of the wiring controller; 2. Replace the cable of the wiring controller; 3. Replace the wiring controller; 4. Replace the indoor control board.	
72	Indoor fan motor fault	1. The cable of the indoor fan motor connect loose; 2. The cable of the indoor fan motor is failure; 3.The indoor fan motor is failure; 4. The indoor control board is failure	1. Reconnect the cable of the fan motor; 2. Replace the cable of the fan motor; 3. Replace the fan motor; 4. Replace the indoor control board; 5. Check the indoor fan and ensure the indoor fan can run normally.	
73	Indoor EEPROM Data 1 fault	1.Indoor EE components is failure; 2.The control circuit of the EE components is failure; 3.The EE components has been inserted with opposite direction	1. Replace the EE components; 2. Replace the indoor control board; 3. Reassembly the EE components of the indoor control board	
74	IndoorEEPROM Data 2 error	EE in MCU is failure,the unit can run ,but the function user has set is eneffective.	Replace EE data in MCU.	
80	Panel key fault	1. The button is failure; 2. The cable of the display board is failure; 3. The display board is failure; 4. The indoor control board is failure	1. Replace the display board; 2. Replace the cable of the display board; 3. Replace the display board; 4. Replace the indoor control board.	

7. TROUBLE SHOOTING

Fault code	Fault Description	Possible Reason of Abnormality	How to Deal With	REMARKS
81	Indoor ambient Temperature Sensor Fault	<ol style="list-style-type: none"> 1. The cable of the room temperature sensor connect loose; 2. The room temperature sensor is failure; 3. The sampling circuit is abnormally 	<ol style="list-style-type: none"> 1.Reconnect the cable of the room temperature sensor; 2. Replace the room temperature sensor; 3. Replace the indoor control board. 	
82	Evaporator Inlet Temperature Sensor Fault	<ol style="list-style-type: none"> 1.The cable of the coil temperature sensor of the evaporator is failure; 2. The coil temperature sensor of the evaporator is failure; 3. The sampling circuit is abnormally 	<ol style="list-style-type: none"> 1.The cable of the coil temperature sensor of the evaporator is failure; 2. The coil temperature sensor of the evaporator is failure; 3. The sampling circuit is abnormally 	
83	Evaporator Middle Temperature Sensor Fault	<ol style="list-style-type: none"> 1.The cable of the coil temperature sensor of the evaporator is failure; 2. The coil temperature sensor of the evaporator is failure; 3. The sampling circuit is abnormally 	<ol style="list-style-type: none"> 1. Reconnect the cable of the coil temperature sensor of the evaporator; 2. Replace the coil temperature sensor of the evaporator; 3. Replace the indoor control board. 	
84	Evaporator outlet Temperature Sensor Fault	<ol style="list-style-type: none"> 1.The cable of the coil temperature sensor of the evaporator is failure; 2. The coil temperature sensor of the evaporator is failure; 3. The sampling circuit is abnormally 	<ol style="list-style-type: none"> 1. Reconnect the cable of the coil temperature sensor of the evaporator; 2. Replace the coil temperature sensor of the evaporator; 3. Replace the indoor control board. 	
85	Wiring Remote Controller Sensor Fault	<ol style="list-style-type: none"> 1. The temperature sensor of the wiring controller is failure; 2. The sampling circuit of the wiring controller is failure 	<ol style="list-style-type: none"> 1. Replace the wiring controller; 2. Replace the wiring controller 	
86	Air outlet temperature sensor fault	<ol style="list-style-type: none"> 1. The cable of the temperature sensor of the air outlet connect loose; 2. The temperature sensor of the air outlet is failure; 3. The sampling circuit is abnormally 	<ol style="list-style-type: none"> 1.Reconnect the cable of the temperature sensor of the air outlet; 2. Replace the temperature sensor of the air outlet; 3. Replace the indoor control board. 	
87	The inlet of water side entrance temperature sensor fault	<ol style="list-style-type: none"> 1. The cable of the temperature sensor of the inlet of water side is failure; 2. The temperature sensor of the inlet of water side is failure; 3.The sampling circuit is abnormally 	<ol style="list-style-type: none"> 1. Reconnect the able of the temperature sensor of the inlet of water side; 2. Replace the temperature sensor of the inlet of water side; 3. Replace the indoor control board. 	

7. TROUBLE SHOOTING

Fault code	Fault Description	Possible Reason of Abnormality	How to Deal With	REMARKS
88	The outlet of water side entrance temperature sensor fault	<ol style="list-style-type: none"> 1. The cable of the temperature sensor of the outlet of water side is failure; 2. The temperature sensor of the outlet of water side is failure; 3. The sampling circuit is abnormally 	<ol style="list-style-type: none"> 1. Reconnect the cable of the temperature sensor of the outlet of water side; 2. Replace the temperature sensor of the outlet of water side; 3. Replace the indoor control board. 	
89	Humidity sensor failure	<ol style="list-style-type: none"> 1. The humidity sensor is failure; 2. The indoor control board is abnormally 	<ol style="list-style-type: none"> 1. Replace the humidity sensor components; 2. Replace the indoor control board. 	
98	Water module DIP switch function select fault	<ol style="list-style-type: none"> 1. DIP switch select failure; 2. DIP is abnormal; 3. Control board is abnormal. 	<ol style="list-style-type: none"> 1. Replace DIP switch; 2. Change DIP switch; 3. Change control board. 	
F0(240)	Wire remote controller EEPROM failure	<ol style="list-style-type: none"> 1. EE of wire remote controller is abnormal; 2. Wire remote controller control board is abnormal. 	Change wire remote controller .	
F1(241)	Wire remote controller temperature sensor failure	<ol style="list-style-type: none"> 1. Temperature sensor of wire remote controller is abnormal; 2. Wire remote controller control board is abnormal. 	Change wire remote controller .	
F2(242)	Wire remote controller clock IC failure	Wire remote controller control board is abnormal.	Change wire remote controller .	
F3(243)	Wire remote controller humidity sensor failure	<ol style="list-style-type: none"> 1. Temperature /humidity sensor of wire remote controller is abnormal; 2. Wire remote controller control board is abnormal. 	Change wire remote controller .	
FE(254)	Communication between main control board & Wiring remote controller Fault (display on wiring remote controller)	<ol style="list-style-type: none"> 1. The wiring between the wiring controller to the indoor control board connect loose; 2. The sequence of the wiring between the wiring controller to the indoor control board is wrong; 3. The wiring between the wiring controller to the indoor control board is failure; 4. The wiring controller is failure; 5. The indoor control board is abnormally 	<ol style="list-style-type: none"> 1. Reconnect the wiring between the wiring controller to the indoor control board; 2. Replace the wiring between the wiring controller to the indoor control board; 3. Replace the wiring between the wiring controller to the indoor control board; 4. Replace the wiring controller; 5. Replace the indoor control board 	

7. TROUBLE SHOOTING

Fault code	Fault Description	Possible Reason of Abnormality	How to Deal With	REMARKS
ER	Communication between main control board & display board Fault (displays on display board)	1.The wiring between the display board to the indoor control board connect loose; 2.The sequence of the wiring between the display board to the indoor control board is wrong; 3.The wiring between the display board to the indoor control board is failure; 4. The display board is failure; 5. The indoor control board is failure.	1. Reconnect the between the display board to the indoor control board; 2. Replace the wiring between the display board to the indoor control board; 3. Replace the wiring between the display board to the indoor control board; 4. Replace the display board; 5. Replace the indoor control board.	

NOTE 1:

If the indoor unit can not turn on or the indoor unit turn off itself after 30s, at the same time the unit do not display the error code, please check the fire and the socket of the control board.

Note 2:

If the indoor unit display the 75,76,77,78 error code after you turn on the unit, please check the TEST seat of the indoor control board or the TEST detection circuit whether exists short circuit.

Note 3:Overload in cooling mode

overload in cooling mode		
sr.	The root cause	Corrective measure
1	The refrigerant is excessive	Discharge the refrigerant, and recharge the refrigerant refer to the rating label
2	The outdoor ambient temperature is too high	Please use within allowable temperature range
3	The air outlet and air inlet of the outdoor unit is short-circuit	Adjust the installation of the outdoor unit refer to the user manual
4	The outdoor heat exchanger is dirty, such as condenser	Clean the heat exchanger of the outdoor unit, such as condenser
5	The speed of the outdoor fan motor is too low	Check the outdoor fan motor and fan capacitor
6	The outdoor fan is broken or the outdoor fan is blocked	Check the outdoor fan
7	The air inlet and outlet has been blocked	Remove the blocked thing

7. TROUBLE SHOOTING

8	The expansion valve or the capillary is failure	Replace the expansion valve or the capillary
---	---	--

Note 4:Over load in heating mode

Overload in heating mode		
sr.	The root cause	Corrective measure
1	The refrigerant is excessive	Discharge the refrigerant, and recharge the refrigerant refer to the rating label
2	The indoor ambient temperature is too high	Please use within allowable temperature range
3	The air outlet and air inlet of the indoor unit is short-circuit	Adjust the installation of the indoor unit refer to the user manual
4	The indoor filter is dirty	Clean the indoor filter
5	The speed of the indoor fan motor is too low	Check the indoor fan motor and fan capacitor
6	The indoor fan is broken or the outdoor fan is blocked	Check the indoor fan
7	The air inlet and outlet has been blocked	Remove the blocked thing
8	The expansion valve or the capillary is failure	Replace the expansion valve or the capillary

7. TROUBLE SHOOTING

The following is the fault code table of driver board.

Analysis of the Driving Board Fault

Driver board fault codes trouble shooting (*Except Free-match 20K&16K DUAL TYPES*), details see sheet 5.

I . Driver fault code display by indicate lamps of driver board flashing. The times that the lamp flashes equal to fault code. Flashing Intervals for a period of time again .Indicator light off when no fault.

For example , fault code 3 : Indicator light flash 3 times and Flashing Intervals for a period of time again, reports No. 3 fault.

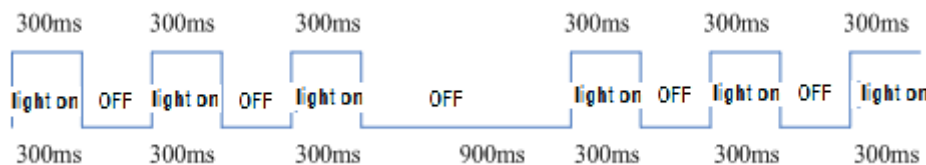

Sheet 5 Driver Error Code -----Except 20K&16 Dual types

Fault code	Fault Description	Possible Reason of Abnormality	How to Deal With
1	Q axis current detection, step out of failure	1, compressor wire connect not well; 2, Bad driver board components; 3, Compressor start load is too large; 4, Compressor demagnetization; 5, Compressor oil shortage, serious wear of crankshaft; 6. The compressor insulation fault	1, Check compressor wire; 2, Change driver board ; 3, Turn on the machine after pressure balance again; 4, Change Compressor; 5, Change the Compressor; 6, Change the Compressor.
2	Phase current detection, out of step	1. Compressor voltage default phase; 2. Bad driver board components; 3. The compressor insulation fault	1, Check compressor wire connection; 2, Change the driver board; 3, Change the Compressor.
3	Initialization, phase current imbalance	Bad driver board components.	Change driver board .
4	Speed estimation, step out of failure	1, Bad driver board components; 2, Compressor shaft clamping; 3. The compressor insulation fault.	1, Change driver board ; 2, Change the Compressor ; 3, Change the Compressor .
5	IPM FO output fault	1. System overload or current overload. 2, Driver board fault; 3, Compressor oil shortage, serious wear of crankshaft; 4, The compressor insulation fault.	1, Check the air-conditioner system; 2, Change the driver board; 3, Change the Compressor; 4, Change the Compressor.

7. TROUBLE SHOOTING

Fault code	Fault Description	Possible Reason of Abnormality	How to Deal With
6	Communication between driver board and control board fault	1,Communication wire connect not well; 2,Driver board fault; 3,Control board fault;	1, Check compressor wire connect. 2,Change the driver board; 3,Change the control board ;
7	AC voltage,overload voltage	1,Supply voltage input too high or too low; 2,Driver board fault;	1,Check power supply; 2,Change the driver board;
8	DC voltage,overload voltage	1,Supply voltage input too high ; 2,Driver board fault;	1,Check power supply; 2,Change the driver board;
9	AC voltage imbalance	Driver board fault;	Change the driver board;
10	The current detection circuit fault	Bad driver board components;	Change the driver board
11	AC voltage supply in	1,Power supply abnormal, power frequency out of range; 2,Driver board fault;	1,Check the system; 2,Change the driver board;
12	Products of single-phase PFC over-current, FO output low level	1,System overload, current too large; 2,Driver board fault; 3,PFC fault.	1,Check the system; 2,Change the driver board; 3,Change PFC.
13	Inverter over current (3-phase power supply air conditioners)	1,System overload, current too large; 2,Driver board fault; 3 , Compressor oil shortage, serious wear of crankshaft; 4,The compressor insulation fault.	1,Check the system; 2,Change the driver board; 3, Change the Compressor; 4, Change the Compressor.
14	Inverter over current	1,System overload, current too large; 2,Driver board fault; 3,Compressor oil shortage,serious wear of crankshaft; 4,The compressor insulation fault.	1,Check the system; 2,Change the driver board; 3, Change the Compressor; 4, Change the Compressor.
15	PFC over current(single-phase air-conditioner)	1,System overload, current too large; 2,Driver board fault; 3,PFC fault..	1,Check the system; 2,Change the driver board; 3,Change PFC.
16	Phase imbalance or phase lacks or the instantaneous power failure (only for 3-phase power supply air conditioners)	1,3-Phase voltage imbalance; 2,The 3-phase power supply phase lost; 3,Power supply wiring wrong; 4,Driver board fault.	1,Check the power supply; 2,Check the power supply; 3,Check the power supply wiring connect; 4,Change the driver board.
17	The instantaneous power failure detection	1,The power supply is not stable ; 2.The instantaneous power failure ; 3,Driver board fault;	1,Check the power supply. 2,Not fault. 3,Change the driver board;
18	Low DC voltage 200V	1,Voltage input too low ; 2,Driver board fault.	1,Check the power supply. 2,Change the driver board.

li : Driver board fault codes trouble shooting (*ONLY FOR 20K&16K DUAL TYPES*), details see sheet6.

2-seconds long LED flash on/off in means number 5 , 1 -second short LED flash on/off means number 1.

7. TROUBLE SHOOTING

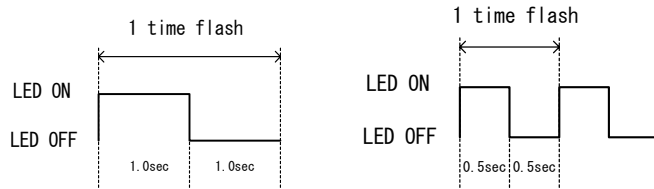

For example , fault code 4 : Indicator light flash 4 times 1-second short LED on/off Intervals for a period of time again, reports No. 4 fault.

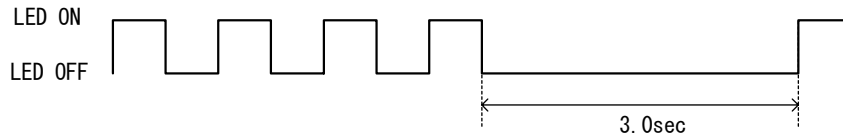

For example , fault code 11 : Indicator light flash 2 times 2-seconds long LED on/off and 1 time 1-second long LED on/off Intervals for a period of time again, reports No. 11 fault.

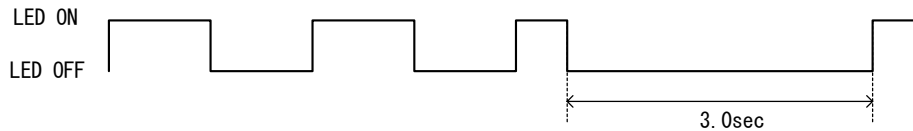

Sheet 6 Driver Error Code

-----Only for 20K&16 Dual types

Fault code	Fault Description	Possible Reason of Abnormality	How to Deal With
1	Inverter DC voltage overload fault	1、 Power supply input too high or too low; 2、 Driver board fault.	1,Check power supply 2,Change driver board.
2	Inverter DC low voltage fault		
3	Inverter AC current overload fault		
4	Out-of-step detection	1、 Compressor phase lost ; 2、 Bad driver board components ; 3、 The compressor insulation fault	1,Check compressor wire connect ; 2,Change driver board ; 3,Change compressor.
5	Loss phase detection fault (speed pulsation)		
6	Loss phase detection fault (current imbalance)		
7	Inverter IPM fault (edge)	1、 System overload or current overload; 2,Driver board fault. 3,Compressor oil shortage, serious wear of crankshaft 4、 The compressor insulation fault	1、 Check the system . 2、 Change driver board; 3、 Change the compressor; 4、 Change the compressor.
8	Inverter IPM fault (level)		
9	PFC_IPM IPM fault (edge)		
10	PFC_IPM IPM fault (level)		
11	PFC power detection of failure	1、 The power supply is not stable ; 2、 The instantaneous power failure ; 3、 Driver board failure.	1、 Check the power supply. 2、 Not abnormal. 3、 Change the driver board.
12	PFC overload current detection of failure.	1、 System overload, current too high ;	1、 Check the system; 2、 Change the driver

7. TROUBLE SHOOTING

Fault code	Fault Description	Possible Reason of Abnormality	How to Deal With
		2、 Driver board failure ; 3、 PFC failure ;	board; 3、 Change the PFC.
13	DC voltage detected abnormal .	1、 Input voltage is too high or too low; 2,Driver board failure ;	1,Check the power supply. 2,Change the driver board;
14	PFC LOW voltage detected failure.		
15	AD offset abnormal detected failure.	Driver board failure.	Change the driver board.
16	Inverter PWM logic set fault.		
17	Inverter PWM initialization failure		
18	PFC_PWM logic set fault.		
19	PFC_PWM initialization fault.		
20	Temperature abnormal.		
21	Shunt resistance unbalance adjustment fault		
22	Communication failure.	1、 Communication wire connect not well. 2、 Driver board failure. 3、 Control board failure.	1、 Check the wiring. 2、 Change the driver board. 3、 Change the control board.
23	Motor parameters setting of failure	Initialization abnormal.	Reset the power supply.

8. CHECKING COMPONENTS

8-1. Check refrigerant system

TEST SYSTEM FLOW

Conditions: ① Compressor is running.

② The air condition should be installed in good ventilation.

Tool: Pressure Gauge

Technique: ① see ② feel ③ test

SEE ----- Tube defrost.

FEEL ----- The difference between tube's temperature.

TEST ----- Test pressure.

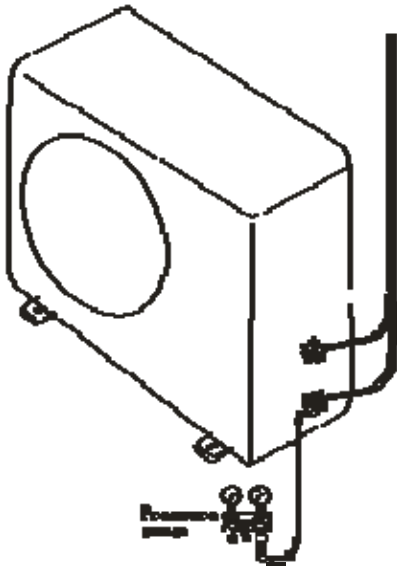

8. CHECKING COMPONENTS

Test system flow

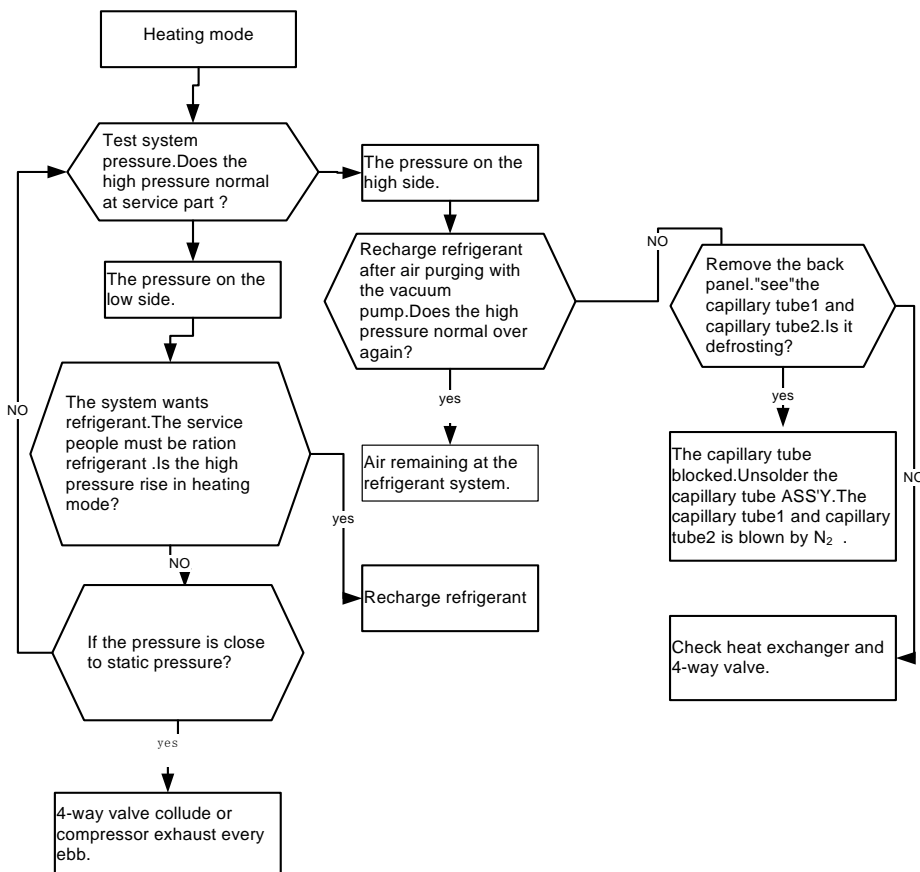
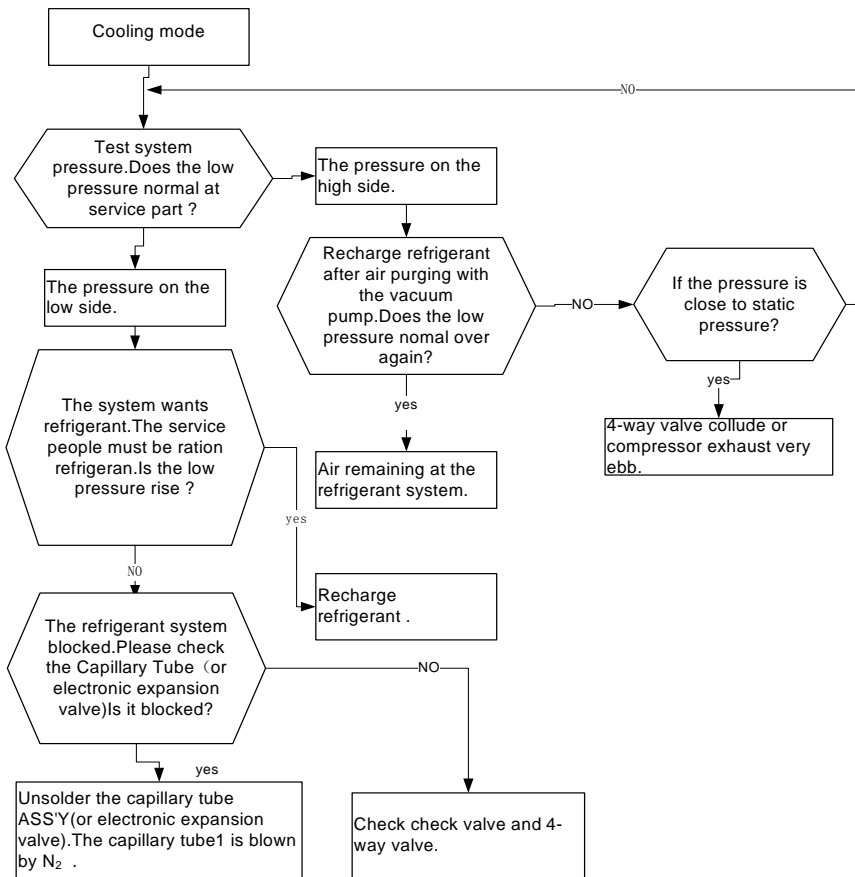

8. CHECKING COMPONENTS

8-2. Check parts unit

1. INDOOR FAN MOTOR

Duct type

18K

YSK110-40-4-A (HS16)

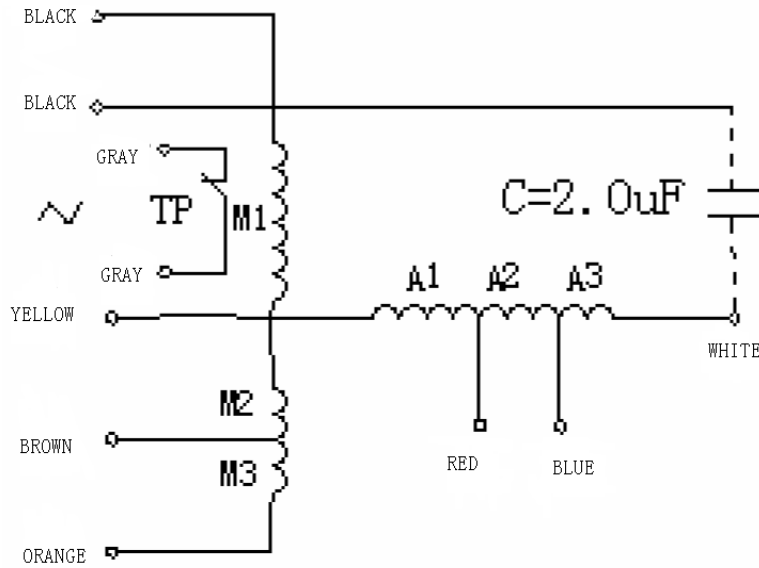

M1: $146 \pm 15\% \Omega$

M2: $33 \pm 15\% \Omega$

M3: $43 \pm 15\% \Omega$

A1: $63 \pm 15\% \Omega$

A2: $23 \pm 15\% \Omega$

A3: $119 \pm 15\% \Omega$

8. CHECKING COMPONENTS

AUD-24UX4SLH

Y6S419C56

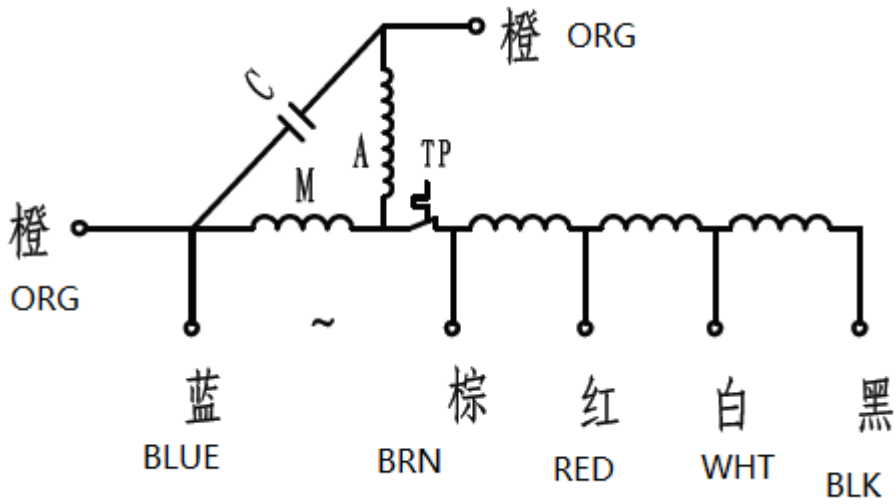

BROWN-BLUE 70.1 [Ω] ± 12%

BROWN-ORANGE 75.5 [Ω] ± 12%

BROWN-RED 10.3 [Ω] ± 12%

RED-WHITE 11.4 [Ω] ± 12%

WHITE-BLACK 16.1 [Ω] ± 12%

AUD-24UX4SLH1

DC MOTOR

AUD-36UX4SMH1

DC MOTOR

8. CHECKING COMPONENTS

AUD-36UX4SMH

Y7S423C024

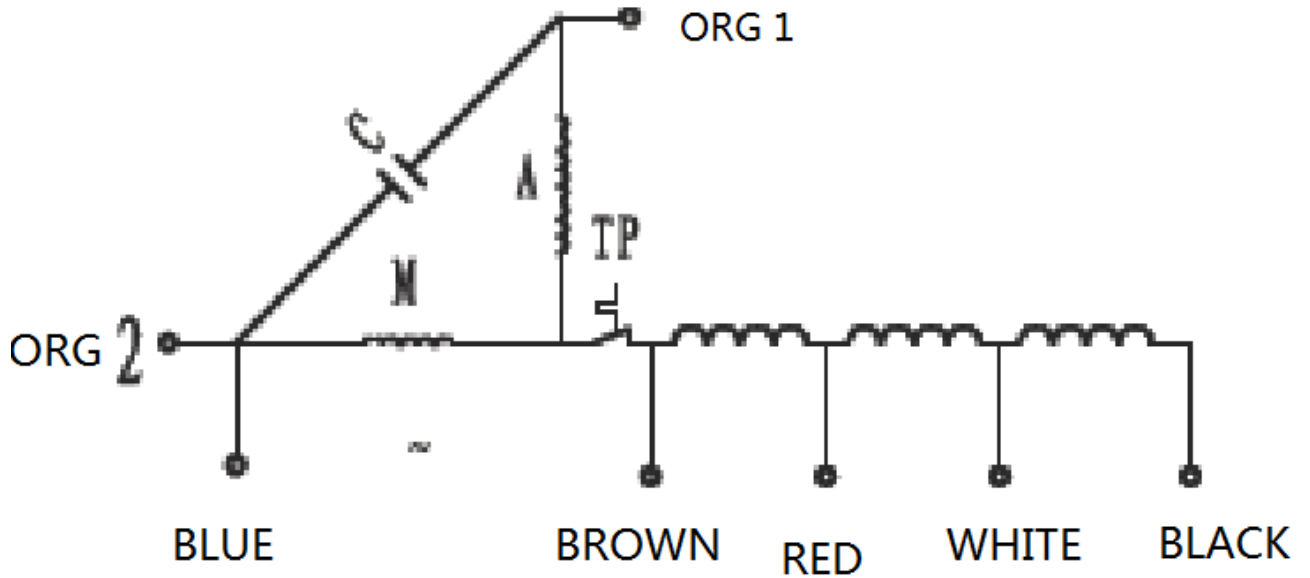

M	23.78 [Ω]	± 12%
A	21.48 [Ω]	± 12%
BROWN-RED	5.15 [Ω]	± 12%
RED-WHITE	2.66 [Ω]	± 12%
WHITE-BLACK	5.07 [Ω]	± 12%

8. CHECKING COMPONENTS

48K,60K

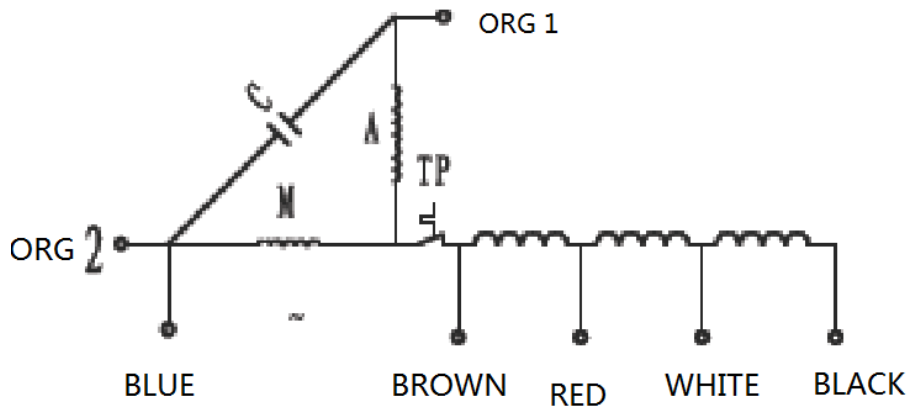

M	17.89 [Ω] ±12%
A	27.2 [Ω] ±12%
BROWN-RED	3.35 [Ω] ±12%
RED-WHITE	4.77 [Ω] ±12%
WHITE-BLACK	2.72 [Ω] ±12%

8. CHECKING COMPONENTS

Cassette

18k

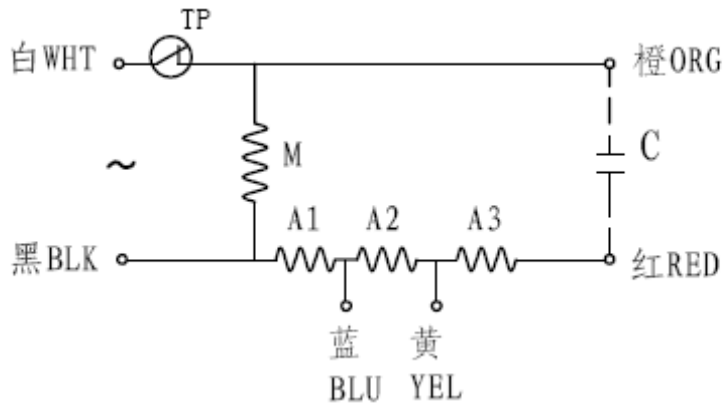

25°C

: M 240 [Ω] ± 15%

:

A1 60 [Ω] ± 15% ; A2 33 [Ω] ± 15% ;

A3 143 [Ω] ± 15% ;

24K,36K,48K,60K

DC-MOTOR

8. CHECKING COMPONENTS

Ceiling & Floor type

18K

YSK110-22-4-A

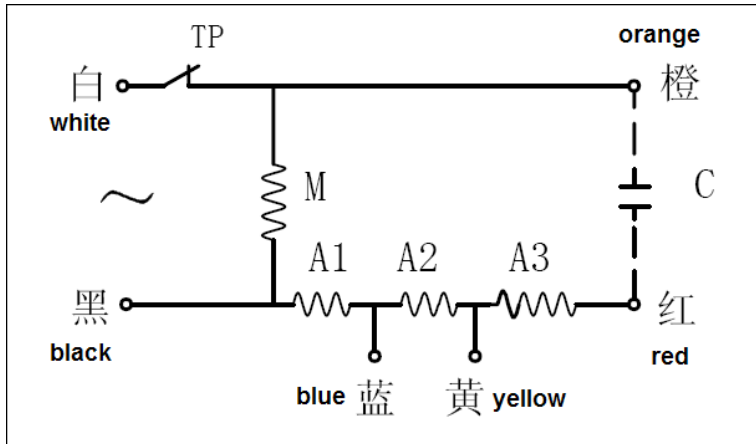

M: $187\ \Omega$ A1: $37.5\ \Omega$ A2: $27.8\ \Omega$ A3: $146\ \Omega$

24K-- DC MOTOR

SIC-70CW-F1100-6

36K-- DC MOTOR

SIC-70CW-F1140-3

48K,60K

Y7S423C032

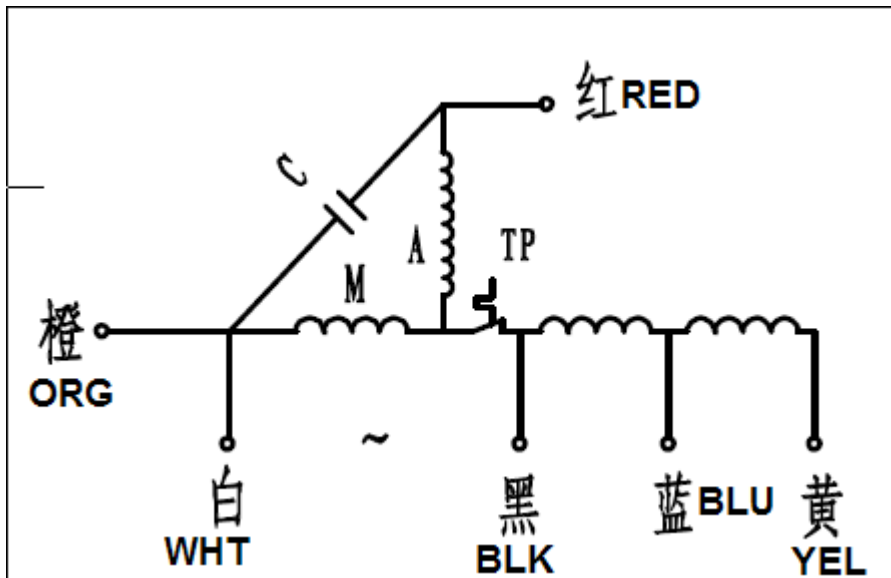

WHITE-BLACK:42.69

BLACK-BLUE:9.19

BLUE-YELLOW:9.09

RED-BLACK:36.41

8. CHECKING COMPONENTS

Test in resistance.

TOOL: Multimeter.

Test the resistance of the main winding. The indoor fan motor is fault if the resistance of main winding 0(short circuit)or ∞ (open circuit) .

Test in voltage

TOOL: Multimeter.

Insert screwdriver into to rotate indoor fan motor slowly for 1 revolution or over, and measure voltage "YELLOW" and "GND" on motor. The voltage repeat 0V DC and 5V DC.

Notes:

- 1) Please don't hold motor by lead wires.
- 2) Please don't plug IN/OUT the motor connecter while power ON.
- 3) Please don't drop hurl or dump motor against hard material. Malfunction may not be observed at early stage after such shock. But it may be found later, this type of mishandling void our warranty.

8. CHECKING COMPONENTS

2. OUTDOOR FAN MOTOR

MOTOR EXAMINE AND REPAIR

Circuit diagram

AUW-18U4SZ1, AUW-24U4SA1&AUW-36U4SA1—DC MOTOR

18K-- MOTOR MODEL:ARW4401QH

24K-- MOTOR MODEL:SIC-71FW-D8121-1

36K-- MOTOR MODEL:SIC-71FW-D8121-1

Circuit diagram

AUW-18U4SG

YDK29-6I-22:

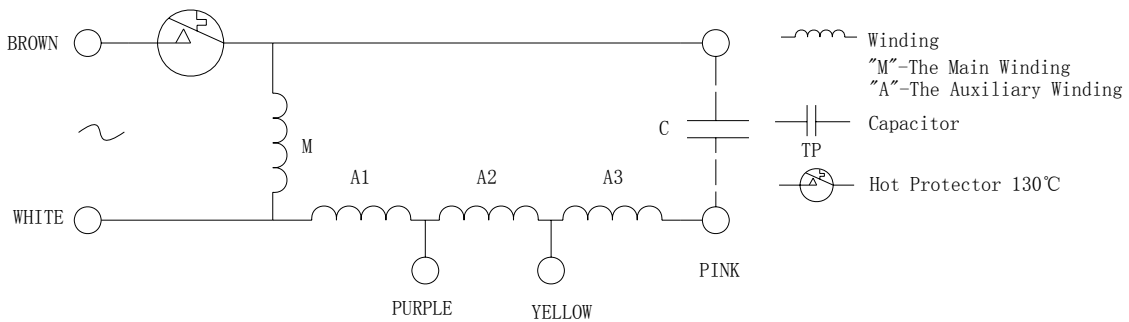

Winding resistance (at 20°C)

M: 283.5 Ω A: 180 Ω

AUW-24U4SZ

YDK70-6H-3:

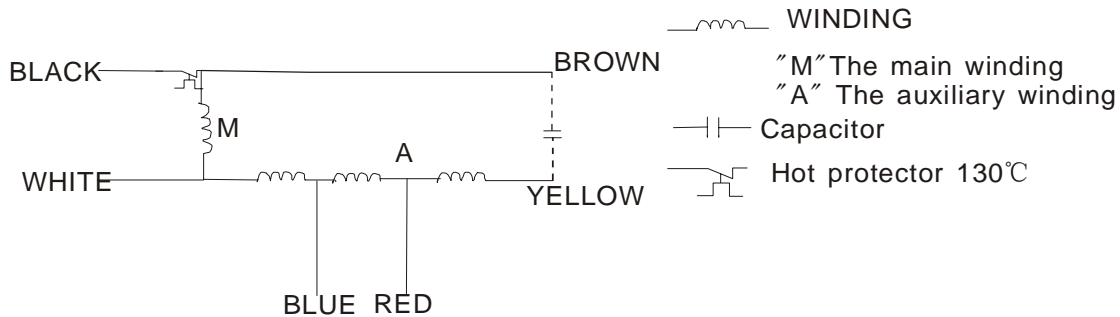

Winding resistance (at 20°C)

M: 78 Ω A: 80 Ω

Winding resistance (at 20°C)

M: 283.5 Ω A: 180 Ω

AUW-36U4SA

YDK95-6-9043

8. CHECKING COMPONENTS

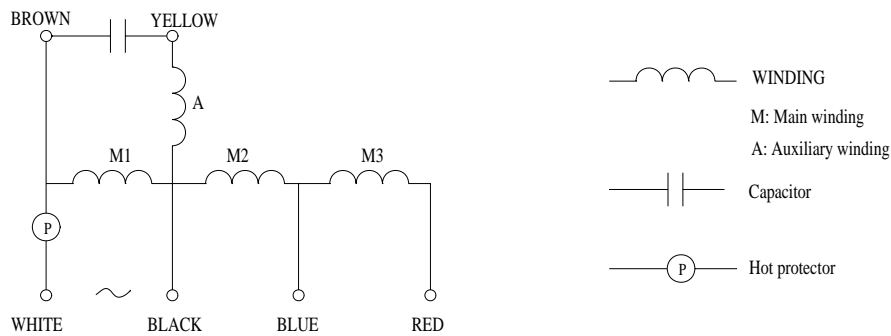

Winding resistance (at 20°C)

M1:59.1 Ω M2:20.3 Ω M3:15.3 Ω A: 85.8 Ω

48K,60K

YDK65-6-9024、YDK65-6-9061

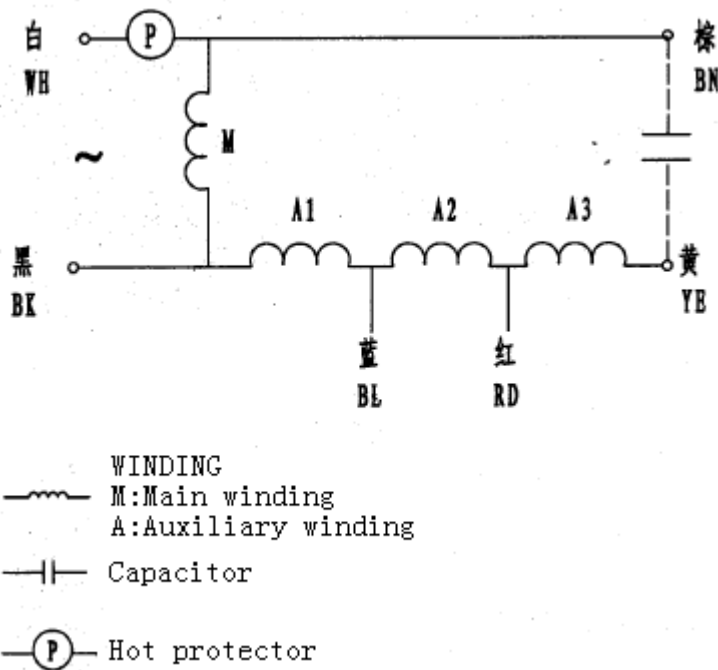

Winding resistance (at 20°C)

M:83.0 Ω A1:23.4 Ω A2:14.0 Ω A3: 63.5 Ω

Test in resistance.

TOOL: Multimeter.

Test the resistance of the main winding. The outdoor fan motor is fault if the resistance of main winding 0(short circuit)or∞ (open circuit) .

Notes:

- 1) Please don't hold motor by lead wires.
- 2) Please don't plug IN/OUT the motor connector while power ON.
- 3) Please don't drop hurl or dump motor against hard material. Malfunction may not be observed at early stage after such shock. But it may be found later, this type of mishandling void our warranty.

8. CHECKING COMPONENTS

3. COMPRESSOR

COMPRESSOR EXAMINE AND REPAIR

AUW-18U4SG: DA130S1C-20FZ

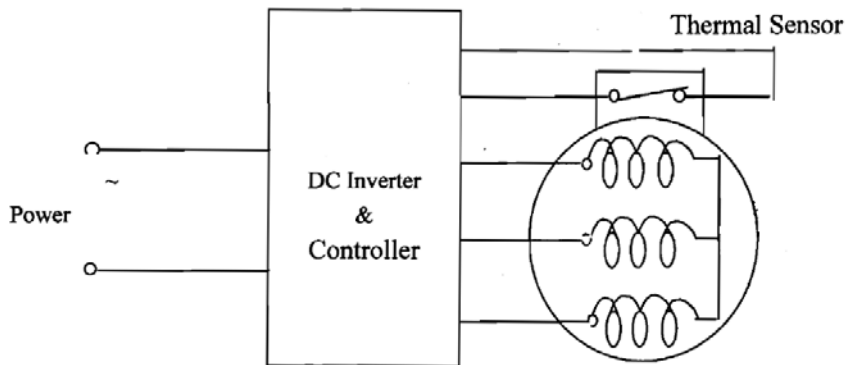

AUW-18U4SZ1

DA131S1B-28FZ

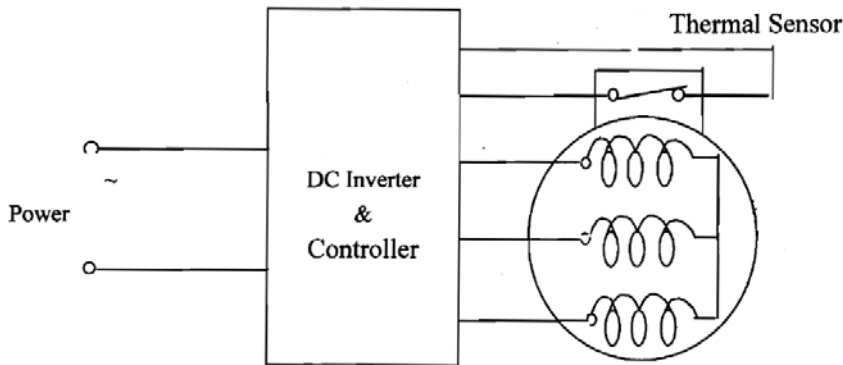

AUW-24U4SZ

WIRING DIAGRAM 接线图

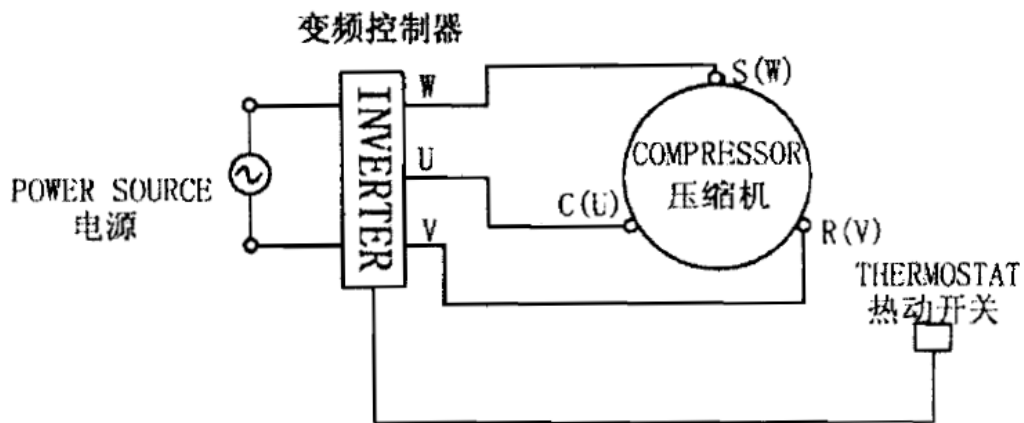

8. CHECKING COMPONENTS

AUW-24U4SA1

DA230S2C-31MT

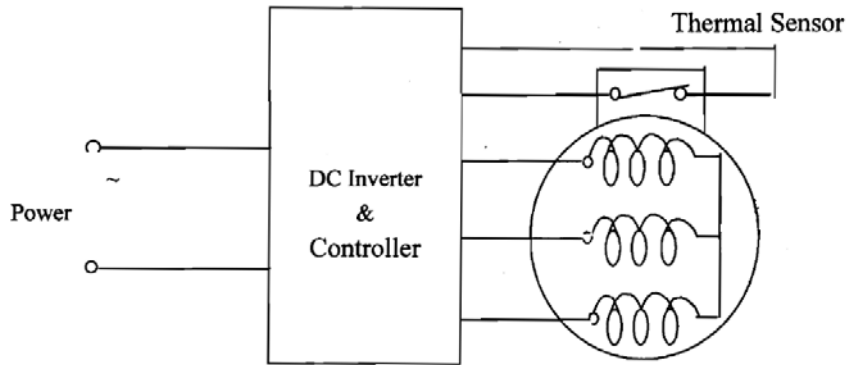

AUW-36U4SA / AUW-36U4SA1

DA250S2C-30MT

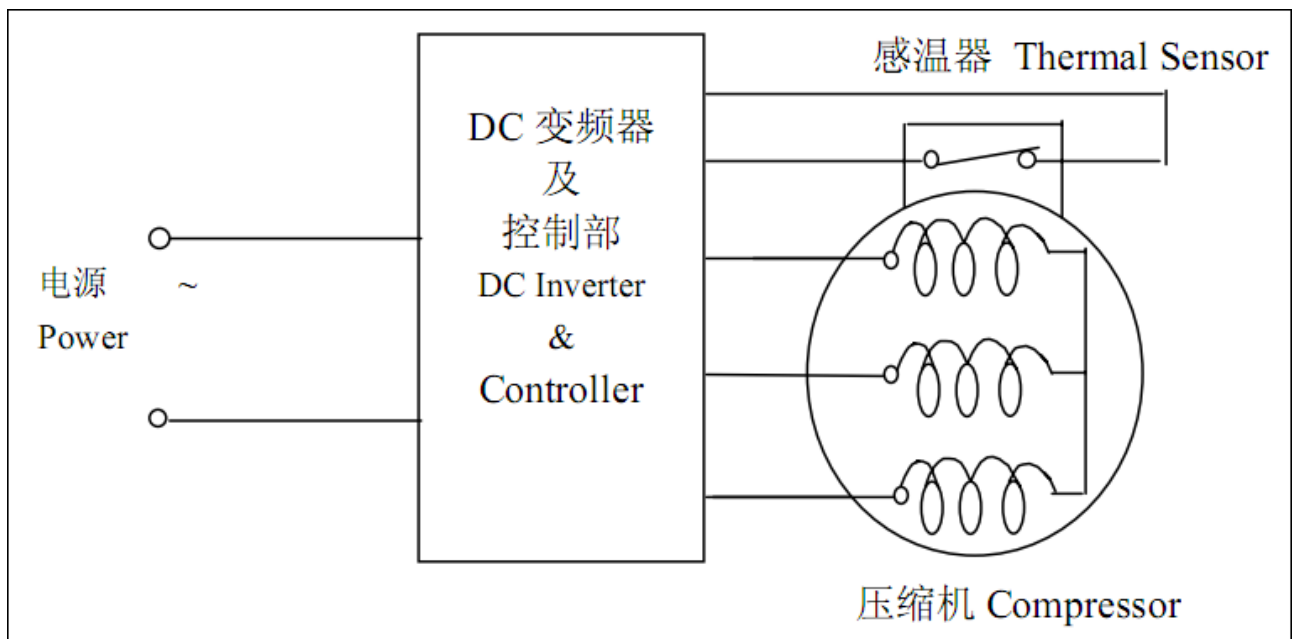

AUW-48U6SP (TNB306FPNMC)

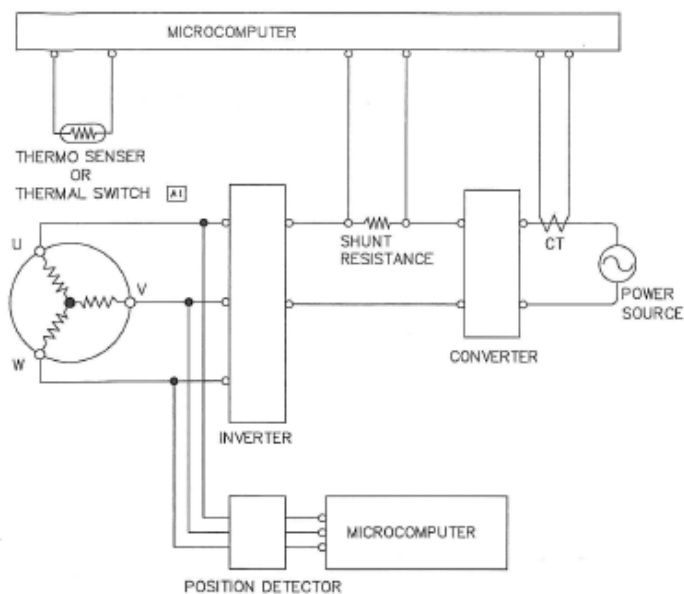

8. CHECKING COMPONENTS

AUW-60U6SP (LNB42FSAMC)

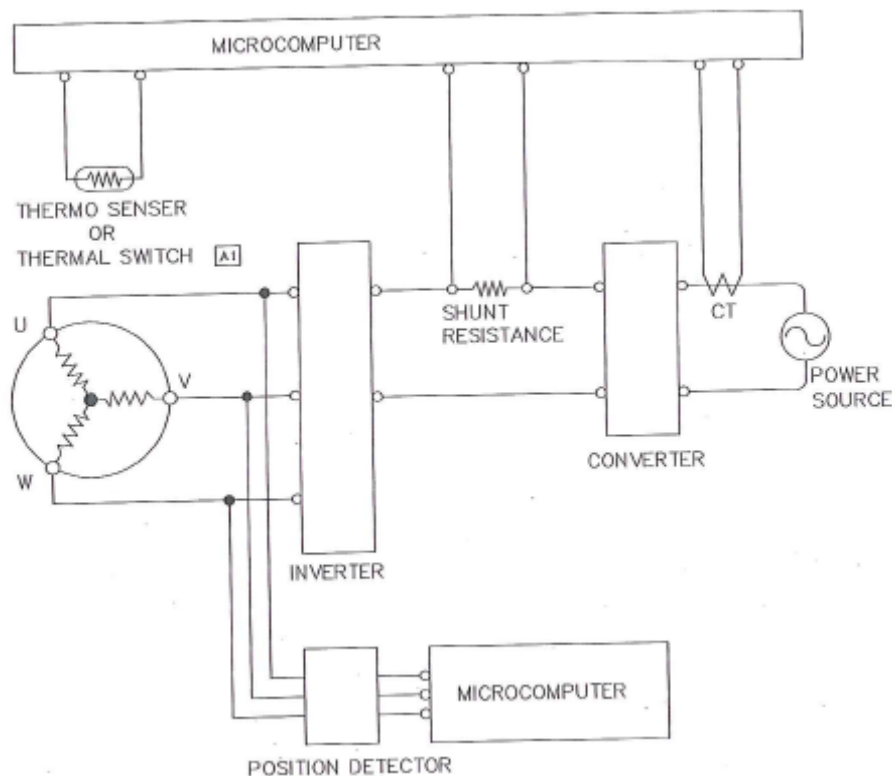

Test in resistance.

TOOL: Multimeter.

Test the resistance of the winding. The compressor is fault if the resistance of winding 0(short circuit)or ∞ (open circuit)

Familiar error:

- 1) Compressor motor lock.
- 2) Discharge pressure value approaches static pressure value .
- 3) Compressor motor winding abnormality.

Notes:

- 1) Don't put a compressor on its side or turn over.
- 2) Please assembly the compressor in your air conditioner rapidly after removing the plugs.
Don't place the comp. In air for along time.
- 3) Avoiding compressor running in reverse caused by connecting electrical wire incorrectly.
- 4) Warning! In case AC voltage is impressed to compressor, the compressor performance will below because of its rotor magnetic force decreasing.

8. CHECKING COMPONENTS

4. INDUCTANCE

Familiar error:

- 1) Sound abnormality
- 2) Insulation resistance disqualification.

5. STEP MOTOR

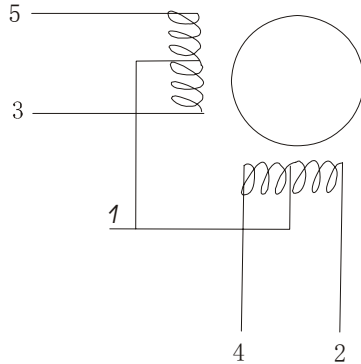

Test in resistance.

TOOL: Multimeter.

Test the resistance of winding. The stepper motor is fault if the resistance of winding 0(short circuit) or ∞ (open circuit) .

6. FUSE

Checking continuity of fuse on PCB ASS'Y.

- 1) Remove the PCB ASS'Y from the electrical component box. Then pull out the fuse from the PCB ASS'Y (Fig.1)

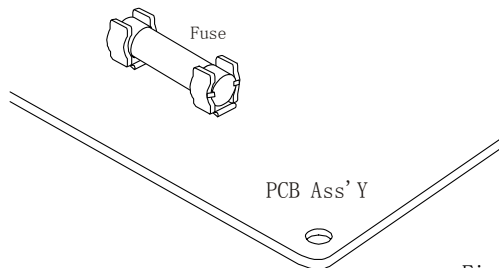

Fig. 1

- 2) Check for continuity by a multimeter as shown in Fig.2.

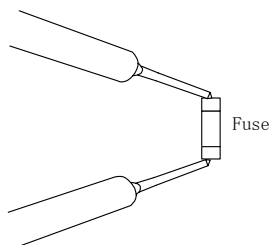

Fig. 2

7. CAPACITOR

- 1) Remove the lead wires from the capacitor terminals, and then place a probe on the capacitor terminals as shown in Fig.3.
- 2) Observe the deflection of the pointer, setting the resistance measuring range of the multimeter to the maximum value.

8. CHECKING COMPONENTS

- * The capacitor is “good” if the pointer bounces to a great extent and then gradually returns to its original position.
- * The range of deflection and deflection time differ according to the capacity of the capacitor.

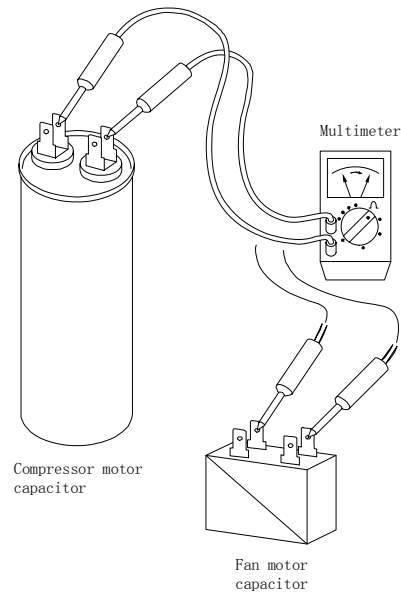

Fig. 3